



HitronTechnologies

HTC-1100E Digital Loop Carrier System Description

September 2003 1B.1

Copyright © 2003 HitronTechnologies All Rights Reserved.

This document contains information that is the property of HitronTechnologies. This document may not be copied, reproduced, reduced to any electronic medium or machine readable form, or otherwise duplicated, and the information herein may not be used, disseminated or otherwise disclosed, except with the prior written consent of **HitronTechnologies**

Contents

NEW PRODUCT INFORMATION RELEASE	5
BROADBAND ADSL SOLUTION	5
QUAD E1 TRANSCEIVER (QE1X-XCVR)	12
ELU-T / EBC-T.....	15
ELU-T / EBC-T.....	16
HTC-2100	18
ISDN- PRI.....	19
QV52 (QV52CU)	22
LAN CARD	25
ADSL G.DMT UNIT	26
G.SHDSL	27
1 INTRODUCTION	30
1.1 KEY FEATURES	30
1.2 SYSTEM DESIGN	30
1.3 SYSTEM EXPANSION	31
1.4 SYSTEM ELEMENTS.....	32
1.4.1 LOCAL EXCHANGE TERMINAL (LET)	32
1.4.2 REMOTE SUBSCRIBER TERMINAL (RST)	32
1.5 REMOTE SUBSCRIBER CABINET	32
1.6 TRANSPORT MEDIA OPTIONS.....	32
1.6.1 FIBER OPTIC TRANSPORT	33
1.6.2 E1 TRANSPORT	33
1.7 NETWORK ARCHITECTURE OPTIONS	33
1.7.1 UNIVERSAL CONFIGURATIONS.....	35
1.7.2 STAR CONFIGURATIONS.....	36
1.7.3 DROP & INSERT CONFIGURATIONS	37
1.7.4 TREE & BRANCH CONFIGURATIONS	38
1.7.5 ENHANCED INTEGRATED INTERFACE CONFIGURATIONS	39
1.7.6 RING CONFIGURATIONS.....	40
1.8 SUBSCRIBER LOOP TESTING CAPABILITIES	41
1.9 CRAFT INTERFACE & ALARM CAPABILITIES	41
1.10 NETWORK MANAGEMENT INTERFACE	43
1.11 PROVISIONING.....	43
1.12 NETWORK EQUIPMENT DATA ADMINISTRATION	43
1.13 PROVISIONING NETWORK EQUIPMENT.....	43
1.14 DIGITAL TRANSMISSION EQUIPMENT PROVISIONING	43
1.15 USER ACCESS PORT PROVISIONING	43
1.16 CONCLUSION	43
2 SYSTEM DESCRIPTION	45
2.1 SYSTEM TERMINALS.....	45
2.2 ASSEMBLIES & HOUSINGS.....	46
2.2.1 CBA	46
2.2.2 FAA	47
2.2.3 RSC/240-360	47
2.2.4 RSC/480-600	47
2.2.5 RSC/1000	47
2.3 COMMON CONTROL UNITS.....	48
2.3.1 CPU	48
2.3.2 EBC	48
2.3.3 ELU	48
2.3.4 L-PSU	48

2.3.5	R-PSU.....	49
2.3.6	MTU.....	49
2.3.7	ATU.....	49
2.3.8	NMI.....	50
2.3.9	E3X-XCVR.....	50
2.4	TRANSCEIVERS.....	50
2.4.1	LINE POWERING E1-XCVR.....	51
2.4.2	E1X-XCVR.....	51
2.4.3	HD-XCVR.....	52
2.4.4	FO-XCVR.....	52
2.4.5	SDH-XCVR.....	52
2.4.6	FOW-XCVR.....	52
2.5	ANALOG CHANNEL UNITS.....	52
2.5.1	LI-POTS CHANNEL UNIT.....	52
2.5.2	RI-POTS CHANNEL UNIT.....	53
2.5.3	LI-APOTS CHANNEL UNIT.....	53
2.5.4	RI-APOTS CHANNEL UNIT.....	53
2.5.5	E&M CHANNEL UNIT.....	53
2.5.6	LI-EPOTS CHANNEL UNIT.....	53
2.5.7	RI-EPOTS CHANNEL UNIT.....	53
2.5.8	L-UVG CHANNEL UNIT SLC-E / DPT.....	54
2.5.9	R-UVG CHANNEL UNIT SLC-T / DPO.....	54
2.6	DIGITAL CHANNEL UNITS.....	55
2.6.1	LET INTERNATIONAL ISDN CHANNEL UNIT (LI-ISDN).....	56
2.6.2	RST INTERNATIONAL ISDN CHANNEL UNIT (RI-ISDN).....	56
2.6.3	ADU CHANNEL UNIT.....	56
2.6.4	SDU CHANNEL UNIT.....	57
2.6.5	N64P CHANNEL UNIT.....	57
2.6.6	E1AX CHANNEL UNIT.....	57
2.6.7	E1X CHANNEL UNIT.....	57
2.6.8	DS1 CHANNEL UNIT (DD1.5).....	57
2.6.9	CO64 CHANNEL UNIT.....	57
2.6.10	DIGITAL DATA 64Kbps(DD64).....	57
2.6.11	ISDN DIGITAL SUBSCRIBER LINE CHANNEL UNIT (IDSL).....	58
2.6.12	CLOCK CARD (CLK CARD).....	58
2.7	CRAFT INTERFACE FEATURES.....	59
2.7.1	PROVISIONING MENU FEATURES.....	59
2.7.2	MAINTENANCE MENU FEATURES.....	59
2.7.3	TESTING MENU FEATURES.....	60
2.7.4	ADMINISTRATION MENU FEATURES.....	60
2.8	ELEMENT MANAGEMENT SYSTEM.....	61
2.8.1	WINDOWS OPERATING SYSTEM.....	61
2.8.2	24-HOUR SYSTEM STATUS DETECTION AND REPORTING.....	61
2.8.3	MANUAL MODE.....	61
2.8.4	REMOTE LOOP TEST OF MTU.....	61
2.8.5	E1 TRANSCEIVER (E1X-XCVR).....	61
2.8.6	THREE-STAGE LOOP TEST OF ATU.....	64
2.8.7	COMPLETE DATABASE CHECKING FUNCTION.....	64
2.8.8	DETAILED ALARM SUPPORT AND EASY SYSTEM CONFIGURATION.....	64
3	GENERAL SPECIFICATIONS.....	65
3.1	TRANSMISSION MEDIA SPECIFICATIONS.....	66
3.2	SIGNALING SPECIFICATIONS.....	67
3.3	VOICE INTERFACE SPECIFICATIONS.....	68
3.4	RINGING SPECIFICATIONS.....	69

3.5	DIALING SPECIFICATIONS	70
3.6	GENERAL SPECIFICATIONS.....	71
3.7	ENVIRONMENTAL SPECIFICATIONS	72
3.8	MECHANICAL SPECIFICATIONS	73
3.9	HTC-1100E RELIABILITY CALCULATIONS	74
4	UNIT DESCRIPTION AND SPECIFICATION.....	75
4.1	APPARATUS.....	76
4.1.1	CHANNEL BANK ASSEMBLY (CBA)	76
4.1.2	FUSE & ALARM ASSEMBLY (FAA).....	77
4.1.3	RSC/240-360	79
4.1.4	RSC/480-600	82
4.1.5	RSC/1000	86
4.2	COMMON UNITS	90
4.2.1	CENTRAL PROCESSING UNIT (CPU)	90
4.2.2	EXPANSION BANK CONTROL (EBC)	93
4.2.3	EXPANSION LINK UNIT (ELU).....	95
4.2.4	LOCAL EXCHANGE TERMINAL POWER SUPPLY UNIT	98
4.2.5	REMOTE SUBSCRIBER TERMINAL POWER SUPPLY UNIT.....	100
4.2.6	METALLIC TEST UNIT.....	103
4.2.7	ANALOG TEST UNIT (ATU)	106
4.3	TRANSCEIVER UNIT	109
4.3.1	LINE POWERING E1 TRANSCEIVER (E1-XCVR)	109
4.3.2	E1 TRANSCEIVER (E1X-XCVR).....	112
4.3.3	FIBER OPTIC TRANSCEIVER (FO-XCVR).....	115
4.3.4	SYNCHRONOUS DIGITAL HIERARCHY TRANSCEIVER	118
4.3.5	MEDIUM RANGE FIBER OPTIC TRANSCEIVER	121
4.3.6	HDSL TRANSCEIVER.....	124
4.4	CHANNEL UNITS.....	127
4.4.1	LOCAL EXCHANGE INTERNATIONAL POTS CHANNEL UNIT	127
4.4.2	REMOTE SUBSCRIBER INTERNATIONAL POTS CHANNEL UNIT	130
4.4.3	LOCAL EXCHANGE INTERNATIONAL ADVANCED POTS CHANNEL UNIT	132
4.4.4	REMOTE SUBSCRIBER INTERNATIONAL ADVANCED POTS CHANNEL UNIT	135
4.4.5	E&M CHANNEL UNIT (E&M)	138
4.4.6	LOCAL EXCHANGE INTERNATIONAL POTS CHANNEL UNIT	141
4.4.7	REMOTE SUBSCRIBER INTERNATIONAL ENHANCED POTS CHANNEL UNIT.....	144
4.4.8	LOCAL EXCHANGE UNIVERSAL VOICE GRADE CHANNEL UNIT	147
4.4.9	REMOTE SUBSCRIBER UNIVERSAL VOICE GRADE CHANNEL UNIT	150
4.5	DIGITAL CHANNEL UNITS	153
4.5.1	LET ISDN CHANNEL UNIT.....	153
4.5.2	RST ISDN CHANNEL UNIT	156
4.5.3	ASYNCHRONOUS DATA CHANNEL UNIT (ADU)	159
4.5.4	SYNCHRONOUS DATA CHANNEL UNIT	162
4.5.5	N64P CHANNEL UNIT	165
4.5.6	E1 ASYNCHRONOUS CHANNEL UNIT	167
4.5.7	E1 CHANNEL UNIT	170
4.5.8	DD1.5 DS1 CHANNEL UNIT	173
4.5.9	CO-DIRECTIONAL 64 KBPS CHANNEL UNIT	175
4.5.10	DIGITAL DATA 64Kbps.....	177
4.5.11	ISDN DIGITAL SUBSCRIBER LINE CHANNEL UNIT.....	180
4.5.12	DLC CLOCK CARD	183
5	V5.2 INTRODUCTION	186
5.1	SYSTEM DESCRIPTION	186
5.2	THE SOFTWARE OF CPU UNIT.....	188
5.3	V52 CHANNEL UNIT FEATURES.....	188

5.4	V5PU CHANNEL UNIT FEATURES.....	188
5.4.1	LAYER2	188
5.4.2	LAYER3	189
5.4.3	LAYER MANAGEMENT ENTITY (LME).....	189
5.4.4	SOFTWARE FEATURES:	189
5.5	V5.2 INTEGRATED DLC APPLICATIONS.....	190
5.5.1	APPLICATION I	190
5.5.2	APPLICATION II.....	191
5.6	UNIT SPECIFICATIONS AND DESCRIPTION	191
5.6.1	V52/V5PU FACEPLANE.....	193
5.7	SYSTEM MODIFICATION	194
6	BROADBAND ACCESS CHANNEL BANK ASSEMBLY (CBA-B).....	195
6.1	OVERVIEW	195
6.2	CBA-B SPECIFICATION.....	197
7	BROADBAND CBA WITH FULL CAPACITY SDH ADM (CBA-BS)	198
7.1	OVERVIEW	198
7.2	CBA-BS SPECIFICATION	199

New Product Information Release

Broadband ADSL Solution

Hitron's broadband ADSL solution provides two interfaces: STM-1 or E1/IMA for connection to ATM switch or SDH at the central office, to offer ADSL service to customers at remote site.

ADSL

ADSL provides ADSL service to the customer at the remote site. Below is the faceplate of the ADSL.

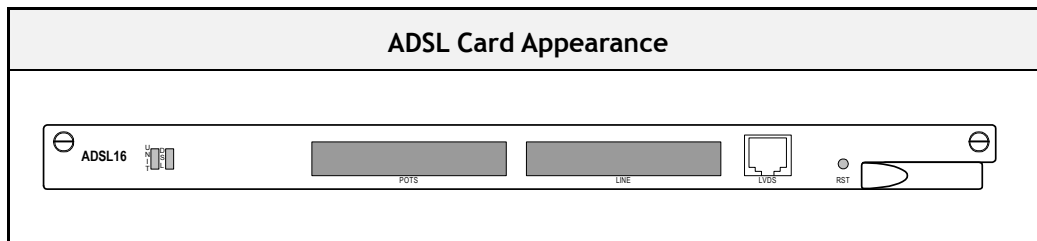

A green UNIT LED indicates the ADSL is in operation status. DSL LED indicates the status of ADSL: green as in operation status, while red indicates out of service.

Both POTS and the LINE port use VF connector (34-pin dual row header). POTS port for telephone service, while LINE port is for ADSL signal. LVDS port is for connection between ADSL and STM1/IMA.

To execute hardware resetting, press the RST button.

Features

- Provides 16 ADSL ports.
- Provides POTS splitter for each ADSL port.
- Supports fast and interleave (SW) configurable modes.
- Supports auto-recovery after each ADSL loop failure.
- Supports rate-adaptation in default.
- With Standard compliance: T1.413, G.DMT, G.Lite. And each ADSL port's operation mode is individually software programmable and query-able.
- Has a HW RESET (RST) button on the front panel.

ADSL Specification	
ADSL Module	<ol style="list-style-type: none"> 1. ADSL signal modulation and demodulation. 2. ADSL to ATM signal conversion. 3. Support Fast/Interleave latency modes for G.dmt 4. Support Interleave mode for G.Lite 5. Build-in POTS splitter circuit. 6. 16 Ports/Card.
ADSL Interface	
Standard Compliant:	ANSI T1.413, G.992.1 (G.DMT), G.992.2 (G.Lite).
POTS Splitter:	G.992.1 Annex E type II
Data Rate (T1.413 and G.992):	Up: 32-1024kbps DOWN: 32K - 12Mbps
Data Rate (G.992.2):	UP: 32 - 1024 Kbps
DOWN: 64K - 4Mbps	
Data Rate (G.992.):	Up to 2320Kbps
Access Interface	
	RJ-45 connector for LVDS link to STM1/IMA.
	ADSL signal connector (34-pin dual row header)
	VF connector (34-pin dual row header)
	HW Reset hidden button.
LED	
	2 LEDs indicate board status and 16 ADSL channels status. (UNIT/DSL)
	Multi-color LED for status indications. (Red, Amber and Green)
Environmental	
	Operating temperature -35°C to +60°C
	Humidity up to 98% at 35°C
Dimensions	291mm × 211mm

IMA

Hitron Broadband ADSL solution also provides an E1 IMA interface to connect to ATM switch in the central office, to provide ADSL at remote site. Below is the faceplate of IMA:

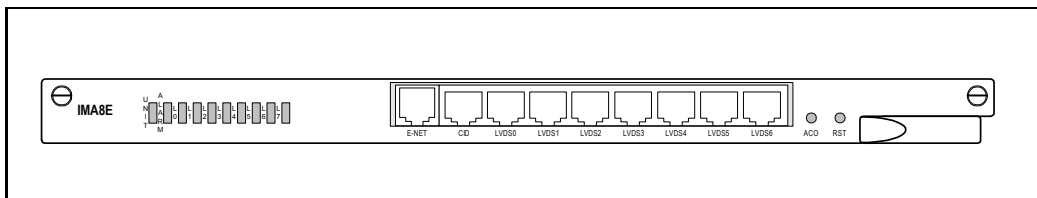

A green UNIT LED indicates the IMA is in operation status. A red ALARM LED indicates alarm has occurred. L0-L7 LEDs indicates the status of each IMA E1: green as in operation status, while red indicates out of service.

Ethernet Port is to connect to LAN for providing system out-band EMS/Telnet control interface, such as system monitor, control or software upgrade, while RS-232 port is to connect to the terminal for monitoring and controlling IMA. LVDS0-6 can be used to connect to service modules via RJ45 jack.

Press the ACO button allow user to clear the current alarm, while the RST button is for hardware resetting.

Features

- Supports 8 E1/DS1 IMA links.
- Supports IMA in both CTC and ITC mode.
- Supports up to 7 service modules including ADSL and SHDSL16 module.
- Provides seven 288 MHz serial LVDS links for communication with service modules over LVDS cables. (RJ45 Jack)
- Supports SW remote download.

IMA Specification	
IMA Module	<ol style="list-style-type: none">1. The E1 interface is compliant with G.703, G.704 and G.823 for physical and jitter characteristic.2. Provides short haul or long haul line selection. Supports IMA in both CTC (common timing clock) and ITC (independent timing clock) mode.
Access Interface	<ol style="list-style-type: none">1. 7 LVDS ports (RJ45 Jack) for connection to service modules.2. An Ethernet port (RJ45 Jack) for connection to LAN and to provide system out-banding EMS/Telnet control interface, such as system monitoring, controlling or software upgrading.3. An RS-232 port (RJ45 Jack) - connect to the terminal for monitoring and controlling IMA.4. HW Reset hidden button.5. HW ACO button.
LED	<ol style="list-style-type: none">1. Provides 10 LEDs to monitor the system operation and to display status of Ethernet, line, remote downloading, as well as IPC and power supply.2. Multi-color LED for status indications. (Red, amber and green)
Environmental	Operating temperature -35°C to +60°C Humidity up to 98% at 35°C
Dimensions	291mm × 211mm (L x W)

STM1D

With Dual optical STM-1 interfaces, STM1D enhances uplink to the ATM switch, ATM access concentrator, or any STM1D in the central office. It controls and transmits DSL traffic between the subscriber equipment (router, bridge/modem or network interface card) and the ATM network.

The STM1D provides a user-networking interface with SONET/SDH processing, and ATM cell mapping at the STM-1 155.52 Mbps rate. It provides the solution to the bridging problem between ATM-IMA-E1 interface and ATM-STM1D-UNI/NNI interface.

The STM1D provides a high bandwidth to assemble the ATM traffic as well as the xDSL service. Since the IMA switch interface is scarce and expensive for service providers, Hitron provides the IMA concentrator to solve this extremity. In addition, STM1D allows more flexibility.

The STM1D can bridge between STM-UNI and E1-IMA with PVC bypass; all the PVC in IMA access side is directly switched to WAN side with one-to-one VCC/VPC mapping.

The IPC (Inter Peripheral Communication) and payload traffic communication between access module and trunk module is through a LVDS link. The IPC will run over HDLC interface as well as the payload is over Pseudo-UTOPIA interface. Below is the faceplate of STM1D:

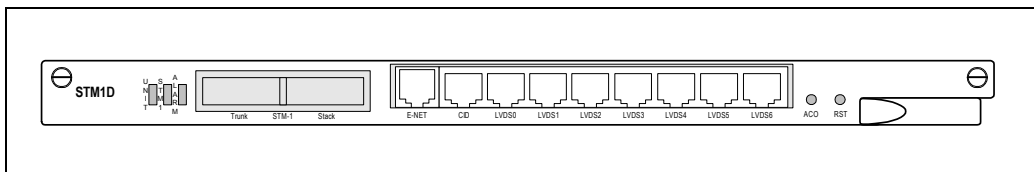

A green UNIT LED indicates the STM1D is in operation status. A green STM1D LED indicates STM-1 interface is in operating status. A red ALARM LED indicates alarm has occurred.

STM-1 is for 155.52 Mbps optical interface for networking interface, while E-NET Ethernet Port is to connect to LAN for providing system out-band EMS/Telnet control interface, such as system monitor, control or software upgrade. CID is a RS-232 port to connect to the terminal for monitoring and controlling the STM1D. LVDS0-6 can be used to connect to service modules.

Press the ACO button allow user to clear the current alarm, while the RST button is for hardware resetting.

Features

- Supports both STS-3C and STM-1 (G.707) frame format and complies with Bell Core GR-253-Core, and ITU-T G.783, G.825 and G.953.
- Supports STM-1 UNI/NNI short-haul optical fiber trunk interface with point-down SC/PC connector.
- Uses SM/MM optical transceiver module with point-down SC/PC duplex connector interface to provide one OC-3 155.52 Mbps rate SONET/SDH physical layer port.
- Supports up to 3 service modules including ADSL and SHDSL16 module.
- Provides three 288 MHz serial LVDS links for communication with service modules over LVDS cables. (RJ45 Jack)
- Provides STM-1 trunk interface for broadband ADSL solution.
- Provides the ATM cell switching capability.

HTC-1100E System Description

- Provides the ATM PHY function, including the TC layer and the PMD layer.
- Provides an internal battery to sustain the system configuration and alarm history for the minimum of three days.

STM1D Specification	
STM1D Interface	<ol style="list-style-type: none">1. Supports STS-3C/STM-1 frame structure and UNI/NNI cell format.2. Provides short haul or long haul line selection.3. Supports IMA in both CTC (common timing clock) and ITC (independent timing clock) mode.
Access Interface	<ol style="list-style-type: none">1. 7 LVDS ports (RJ45 Jack) for connection to service modules.2. STM-1 optical interface - SC/PC connector for network interface. (155.52Mbps)3. 7 LVDS ports (RJ45 Jack) for connection to service modules.4. An Ethernet port (RJ45 Jack) for connection to LAN and to provide system out-banding EMS/Telnet control interface, such as system monitoring, controlling or software upgrading.5. An RS-232 port (RJ45 Jack) - connect to the terminal for monitoring and controlling the STM1.6. HW Reset hidden button.7. HW ACO button.
LED	<ol style="list-style-type: none">1. 3 LEDs for monitoring the system operation, STM-1 status and alarm status. (UNIT, STM1, ALARM)2. Multi-color LED for status indications. (Red, amber and green)
Environmental	Operating temperature -35°C to +60°C Humidity up to 98% at 35°C
Dimensions	291mm × 211mm (L x W)

Quad E1 Transceiver (QE1X-XCVR)

The HTC-1100E Quad E1 Transceiver provides four (4) E1 (G.703) level interfaces, transmitting and receiving up to 4x30 Basic 64 Kbps channels of voice or data originating from either the channel unit or another transceiver. The QE1X-XCVR may be used as the channel unit or E1 transceiver. It operates at the E1 rate of 2.048 Mbps. The QE1X-XCVR is intended for use in applications requiring interface to multiplexers or other co-located office equipment.

The QE1X-XCVR Transceiver performs signaling conversion and data link termination. Line coding is HDB3. The transceiver has selectable alarm thresholds, BER calculation, performance monitoring statistics, and alarm history.

The QE1-XCVR may also be used as a service card; to drop off four (4) channelized E1 circuits to customers' G.703 equipment.

.

Features

- Four ITU-T/E1 2.048 Mbps Interface per card
- Double frame, CRC multi-frame formats
- Extensive Loopback Diagnostics
- Remote Test Access to Metallic Tip and Ring (In the future)
- Low Power Dissipation
- Support fractional E1 to customers or for groomed services

Faceplate of QE1X-XCVR

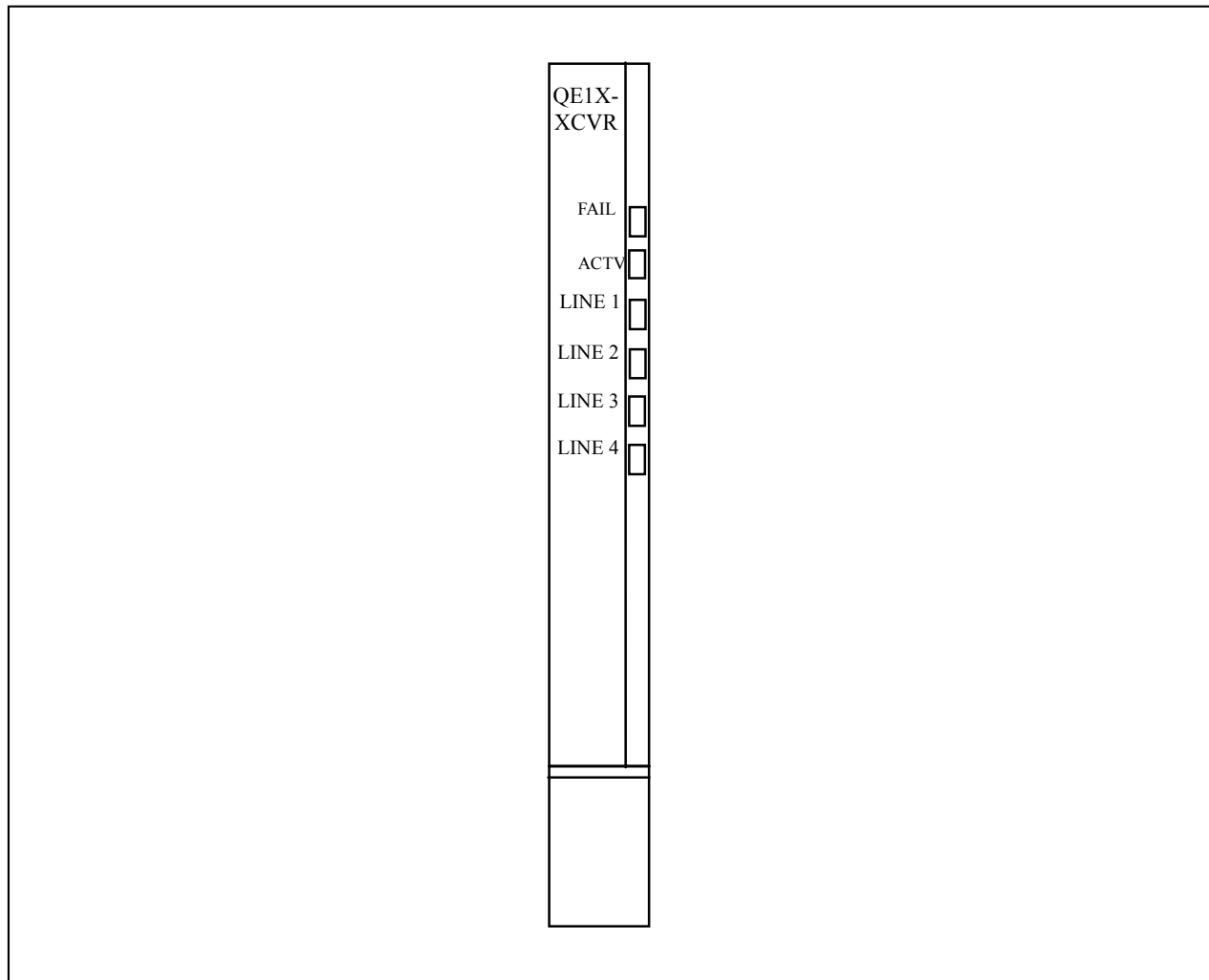

QE1X-XCVR Specification	
<u>Signaling Features</u>	
Line Rate	2.048 Mbps ± 50 ppm
Framing	Double frame, CRC multi-frame
Line Coding	HDB3
Channel sequence	CAS or CCS
Error Checking	CRC4
Loopback Modes	Local, Remote
<u>Analog Parameters</u>	
Input Impedance	75Ω(unbalanced))
<u>Environmental</u>	
Operating temperature	-35°C to +60°C
Humidity	up to 98% at 35°C
Max Power Consumption	2.5 W
<u>Dimensions</u>	
	5.125" (13.018 cm) tall (standing up in CBA)
	10.5" (26.67 cm) long (from front of CBA to CBA backplane)
	0.563" (1.429 cm) thick (measured along faceplate - thickest point)
<u>Weight</u>	
	0.5 lbs (0.23 Kilograms)
<u>Compliance</u>	
Jitter	ITU-T G.703 / G.823
Cable Interface	ITU-T G.703
Return Loss	ITU-T G.703
Frame/CRC-4 Multiframe	ITU-T G.704 / G.706
LOF and recovery	ITU-T G.706
LOS	ETSI 300 461-1

System Craft Interface functions inquiries :

- (1) Transceiver setting (On/Off, Grooming On/Off)
- (2) Groomed Cross-connect setting
- (3) Performance (ES, SES, UAS)
- (4) Diagnostic (NE, FE Lookback, CRC-4)
- (5) PCM30/31 setting
- (6) ABCD bits
- (7) Timing source enable/disable

Faceplate’s LEDs definition :

- (1) Fail: Red LED indicates card failure
- (2) Active : Green LED indicates card in normal condition
- (3) L1 : Green/Amber LED. Green LED indicates E1 in normal condition. Blinking Amber LED indicates E1 in alarm condition. Static amber LED indicates loopback condition.
- (4) L2 : Green/Amber LED. Green LED indicates E1 in normal condition. Blinking Amber LED indicates E1 in alarm condition. Static amber LED indicates loopback condition.
- (5) L3 : Green/Amber LED. Green LED indicates E1 in normal condition. Blinking Amber LED indicates E1 in alarm condition. Static amber LED indicates loopback condition.
- (6) L4 : Green/Amber LED. Green LED indicates E1 in normal condition. Blinking Amber LED indicates E1 in alarm condition. Static amber LED indicates loopback condition.

System Wiring definition :

- (1) 12-Pins connector from backplane wiring to provide four (4) pair of BNC (75 Ohm) male connectors.
- (2) The wiring cable is 1.0 meter long. As below diagram
- (3) 1 U front access panel with 16-pair of male-2-male connector as below diagram

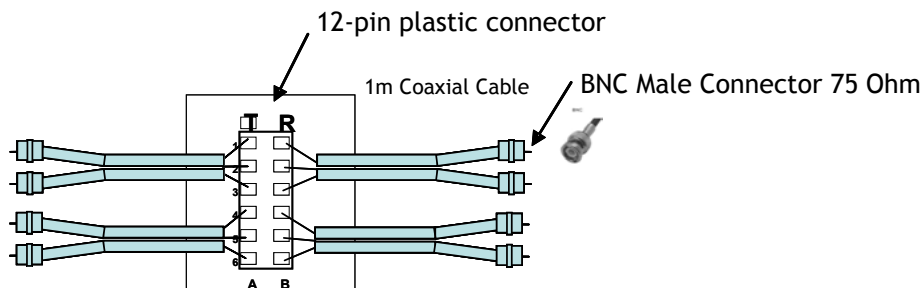

Backplane Cable Wiring for QV52



16-pair 75/75 Ohm Panel (Male-to-Male)

ELU-T / EBC-T

ELU-T/EBC-T are used as inter-connection between primary and expansion shelf of HTC-1100E. The ELU-T/EBC-T are adopting state-of-the-art low-voltage differential signaling (LVDS) technology, which now is widely used in high-speed analog circuit techniques to provide multigigabit data transfers on copper interconnects, including serializing data, encoding the clock, and low skew features.

Low-voltage signals have many advantages, including fast bit rate, and better noise performance. And with differential signal paths, it can reduce the harmful effects of these fields to minimize radiation problems further. Furthermore, rather than multi-mode fiber cord, the inter-connection cable between ELU-T and EBC-T uses shielded Cat-5 cable to facilitate the ease and flexibility of system installation and commission.

Hitron maps to cut-in the ELU-T/EBC-T at early July of 2003. This release can co-work with existing ELU/EBC in the same system (see Figure 1), surely without conflicting on system upgrade and expansion. In the meantime, the previous version of ELU/EBC will be discontinued. However, the maintenances, supports and other RMA issues will be still continually providing to current users of Hitron.

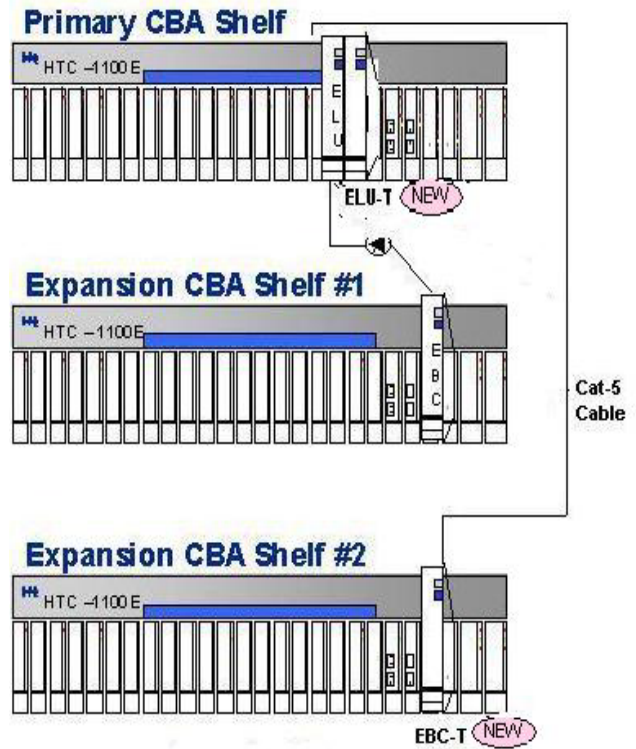

Figure 1: Application

EBC-T Specification	
Interface Specification	
Transmission Rate:	49.152 Mbps
Transmitter/Receiver	LVDS
Connector type	CAT5
Environment	
Operating temperature	-35°C to +60°C
Humidity	up to 98% at 35°C
Maximum Power Consumption	7.0 W
Dimensions	
	5.125" (13.018 cm) tall (standing up in CBA)
	10.5" (26.67 cm) long (from front to backplane of CBA)
	0.563" (1.429 cm) thick (along faceplate - thickest point)
Weight	
	0.5 lbs (0.23 Kilograms)

ELU-T Specification

Interface Specification

Transmission Rate: 49.152 Mbps
Connector type CAT5

Environmental

Operating temperature -35°C to +60°C
Humidity up to 98% at 35°C
Power Consumption 7.0 W

Dimensions

5.125" (13.018 cm) tall (standing up in CBA)
10.5" (26.67 cm) long
(From front of CBA to CBA backplane)
00.563" (1.429 cm) thick (along faceplate thickest point)

Weight

0.5 lbs (0.23 Kilograms)

HTC-2100

The HTC-2100 is a stand-alone set-top unit. The front panel contains four keypads, a LCD screen, and twelve Light Emitting Diodes (LED) so that the controls and indicators may be read directly. The rear panel contains a power cord, power switch, a standard 8-pin line jack, and two DTE connector ports, which provide EIA-232, interface. There are four-dip switches, which are used to select V.35 or V.36 interface in the bottom cover.

HTC-2100 Specification	
<u>Interface Specification</u>	
Operating Mode:	2B1Q code, 2-wire non-loaded cable, Full duplex
Data Rates:	160Kbps
DTE Interface:	ITU-T V.35 and EIA-RS-449 connector
Network Interface:	RJU45 connector or Terminal Block
Line Interface:	2-wire, full-duplex, non-load cable, RJ45 connector
<u>Clocking</u>	
Line Clock:	Clock source from looping timing
Internal Clock:	Clock source from NTU-128K self-timing
External Clock:	Clock source from DTE equipment
<u>Environmental</u>	
Operating temperature	-35°C to +60°C
Humidity	up to 98% at 35°C
Power	110/220 ± 10%Vac, 57 ~ 63 Hz
<u>Dimensions</u>	
	56mm Height
	270mm Depth
	200mm Width
<u>Weight</u>	2.09 lbs (0.95 Kilograms)
<u>Packaging</u>	Standalone

ISDN- PRI

The HTC-1100E E1 Transceiver provides an indoor E1 (G.703) level interface, transmitting and receiving up to 30 Basic 64 Kbps channels of voice or data originating from either the channel unit or another E1 transceiver. The ISDN-PRI used at either the channel units or another E1 transceiver. It operates at the E1 rate of 2.048 Mbps. The ISDN-PRI is intended for use in applications requiring interface to multiplexers or other co-located office equipment. Its faceplate is shown on this page.

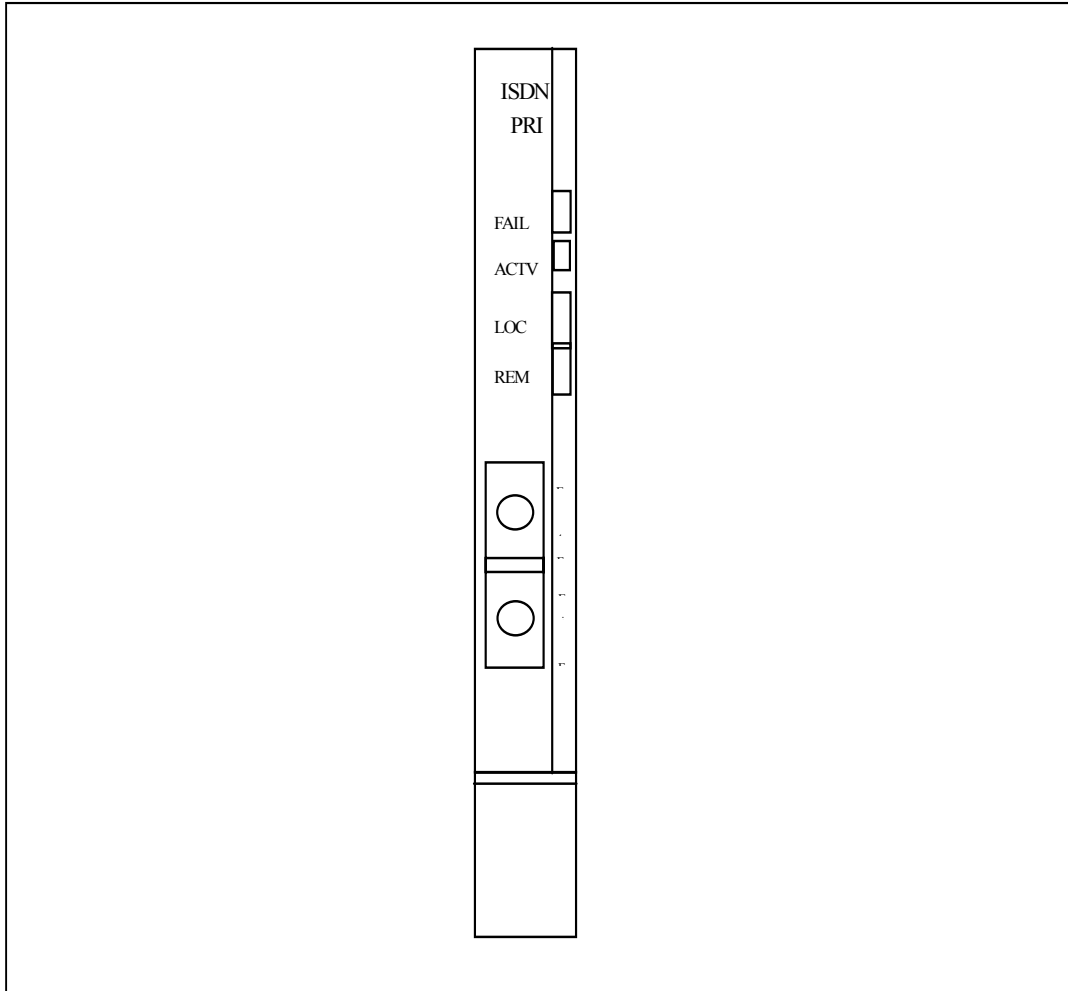

The ISDN-PRI Transceiver performs signaling conversion and data link termination. Line coding is HDB3. The transceiver has selectable alarm thresholds, BER calculation, performance monitoring statistics, and alarm history.

The ISDN-PRI may also be used as a service card, to drop off a single channelized E1 circuit to a customer's G.703 equipment.

There are four LED indicators on the ISDN-PRI Transceiver front panel. A green ACTV LED indicates the unit is busy and must not be unplugged without first removing traffic. A red FAIL LED indicates that the unit has failed. An amber REM LED indicates that the unit is in Far End Alarm, and another amber LOC LED indicates that the unit is in Near END alarm. The transceiver features front panel jack access for testing and monitoring.

Features

- One ITU-T/E1 2.048 Mbps Interface per card
- Double frame, CRC multi-frame formats
- Extensive Loopback Diagnostics
- Front Panel Jack Access for Test and monitoring
- Remote Test Access to Metallic Tip and Ring (In the future)
- Low Power Dissipation

ISDN-PRI Specification	
<u>Signaling Features</u>	
Line Rate	2.048 Mbps ± 50 ppm
Framing	Double frame, CRC multi-frame
Line Coding	HDB3
Channel sequence	CAS or CCS
Error Checking	CRC4
Loopback Modes	Local, Remote
<u>Analog Parameters</u>	
Equalization	Receive Automatic Line Build Out (10 dB attenuation)
	Transmit Fixed 3.0 Vpk±0.3 Vpk
Input Impedance	120Ω(twisted pair)
<u>Environmental</u>	
Operating temperature	-35°C to +60°C
Humidity	up to 98% at 35°C
Max Power Consumption	2.5 W
<u>Dimensions</u>	
	5.125" (13.018 cm) tall (standing up in CBA)
	10.5" (26.67 cm) long (from front of CBA to CBA backplane)
	0.563" (1.429 cm) thick (measured along faceplate - thickest point)
<u>Weight</u>	
	0.5 lbs (0.23 Kilograms)
<u>Compliance</u>	
Jitter	ITU-T G.703 / G.823
Cable Interface	ITU-T G.703
Return Loss	ITU-T G.703
Frame/CRC-4 Multiframe	ITU-T G.704 / G.706
LOF and recovery	ITU-T G.706
LOS	ETSI 300 461-1

QV52 (QV52CU)

QV52 Channel Unit (QV52) provides four (4) E1 physical links, which comply with ITU-T G.703, G.704, and G.706.

QV52 Specifications	
<u>Signaling Features</u>	
Complied with	ITU-T G.965
Framing	Double frame, CRC multi-frame
Line Coding	HDB3
Error Checking	CRC4
Loopback Modes	Local, Remote
<u>Analog Parameters</u>	
Equalization	Receive Automatic Line Buildout (10 dB attenuation)
Input Impedance	75Ω(twisted pair)
<u>Environmental</u>	
Operating temperature	-35°C to +60°C
Humidity	up to 98% at 35°C
Max Power Consumption	2.5 W
<u>Dimensions</u>	
	5.125" (13.018 cm) tall (standing up in CBA)
	10.5" (26.67 cm) long (from front of CBA to CBA backplane)
	0.563" (1.429 cm) thick (Measured along faceplate - thickest point)
<u>Weight</u>	
	0.5 lbs (0.23 Kilograms)
<u>Compliance</u>	
Jitter	CCITT G.823
Cable Interface	CCITT G.703

Faceplate of QV52

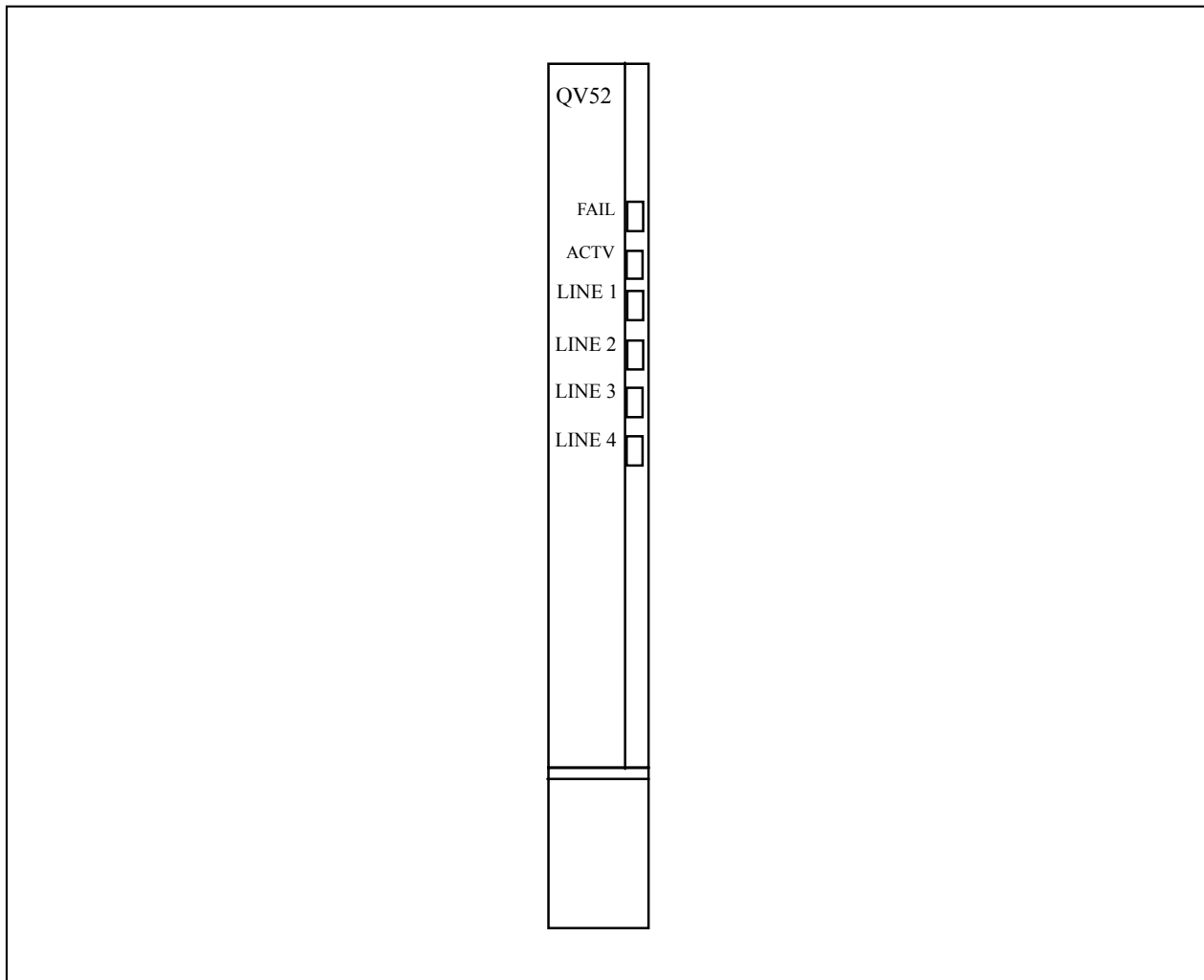

System Craft Interface functions inquiries :

- (1) Performance (ES, SES, UAS)
- (2) Diagnostic (NE, FE Lookback, CRC-4)
- (3) Timing source enable/disable

Faceplate's LEDs definition :

- (1) Fail: Red LED indicates card failure
- (2) Active : Green LED indicates card in normal condition
- (3) L1 : Green/Amber LED. Green LED indicates E1 in normal condition. Blinking Amber LED indicates E1 in alarm condition. Static amber LED indicates loopback condition.
- (4) L2 : Green/Amber LED. Green LED indicates E1 in normal condition. Blinking Amber LED indicates E1 in alarm condition. Static amber LED indicates loopback condition.
- (5) L3 : Green/Amber LED. Green LED indicates E1 in normal condition. Blinking Amber LED indicates E1 in alarm condition. Static amber LED indicates loopback condition.
- (6) L4 : Green/Amber LED. Green LED indicates E1 in normal condition. Blinking Amber LED indicates E1 in alarm condition. Static amber LED indicates loopback condition.

System Wiring definition :

- (1) 12-Pins connector from backplane wiring to provide four (4) pair of BNC (75 Ohm) male connectors.
- (2) The wiring cable is 1.0 meter long. As below diagram
- (3) 1 U front access panel with 16-pair of male-2-male connector as below diagram

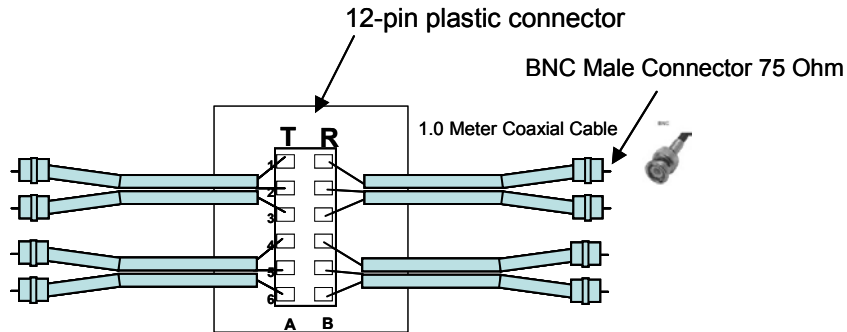

Backplane Cable wiring for QV52



16-Pair 75/75 Ohm Panel (Male-to-Male)

LAN Card

The Internet Protocol Management Interface (IPMI) plug-in card enables the Element Management System (EMS) for the HTC-1100E and provides secure, remote access to the HTC-1100E Craft Interface via Telnet.

The IPMI plug-in card provides the physical 10Base-T interface used for interconnection to a LAN/WAN via a hardwired connection on the backplane. Provision the IPMI's IP address via the Craft Interface. The card hosts a number of applications, such as Telnet and a Simple Network Management Protocol (SNMP) agent.

Telnet supports FCAPS management for the HTC-1100E via a Telnet connection to the Craft Interface. Telnet allows a connection over IP between the user's computer system and the HTC-1100E. It is essentially a pipe that enables use of all Craft Interface commands and functions from anywhere on an IP network.

SNMP is an application layer protocol utilizing the standard Management Information Base (MIB II) as well as a HTC-1100E enterprise MIB. The SNMP in conjunction with the MIBs enables HTC-1100E communications with EMS and support for the FCAPS.

EMS is a graphical user interface (GUI) that enables centralized management of multiple HTC-1100E systems. EMS features Fault, Configuration, Performance, and Security (FCAPS) management. Other information please refer to Page 43

Features

The IPMI plug-in card has the following features:

- Ability to host an SNMP agent
- Provides Telnet connection to Craft Interface
- Enables Element Management System (EMS)
- Conforms to MIB II standards

ADSL G.dmt Unit

The ADSL (G.dmt ADSL unit) provides broadband data service over twisted copper pairs using the Discrete Multitone (DMT) line coding which is compliant with ITU-T G.992.1 (G.dmt).

ADSL is a broadband service providing simultaneous high-speed data access and voice service over existing copper loops. The ADSL unit provides up to 8Mbps downstream, towards the CPE, and up to 0.64Mbps upstream over unloaded twisted pairs; greatly increase the speed of data access over the local loop.

The ADSL unit allows voice and broadband data services to be deployed from a single platform, eliminating the need for a standalone miniDSLAM.

Features

- Internal DLC card
- Compatible with the ADSL modem/router
- Compliant to ITU-T G.992.1
- Support 4 ports of G.dmt port per card

ADSL Specifications	
<u>Signaling Features</u>	
Complied with Data rate	ITU-T G.992.1 (G.dmt) G.dmt rate adaptive upto 8Mbps (downstream), 0.64Mbps (upstream)
Card Capacity	4 ADSL ports
<u>Analog Parameters</u>	
Equalization	Receive Automatic Line Buildout (10 dB attenuation)
Input Impedance	75Ω(twisted pair)
<u>Environmental</u>	
Operating temperature	-35°C to +60°C
Humidity	up to 98% at 35°C
Max Power Consumption	8.2 W
<u>Dimensions</u>	
	5.125" (13.018 cm) tall (standing up in CBA) 10.5" (26.67 cm) long (from front of CBA to CBA backplane) 0.563" (1.429 cm) thick (Measured along faceplate - thickest point)
<u>Weight</u>	0.66 lbs (0.3 Kilograms)

G.SHDSL

Hitron G.SHDSL solution provides high-speed symmetric data transmission over existing copper wires, without requiring the installation of additional cable.

Hitron G.SHDSL solution consists of card unit and standalone unit. The shelf type unit, named as SHDSL-XCVR, would be equipped with Hitron HTC-1100E DLC System to provide a G.SHDSL access solution to customers. The standalone unit, HTC-4100, is a remote standalone customer premises equipment with various interfaces such as V.35, E1 and LAN, providing flexible data services. Also that HTC-4100 can be configured as network termination unit and line termination unit to provide a point-to-point leased line application.

With centralized SNMP-based NMS, remote Web-based GUI, and management IP control list, Hitron G.SHDSL solution provides excellent management with security. The SHDSL-XCVR can also be configured as a transceiver unit of the HTC-1100E DLC system to provide a high capacity pair-gain solution.

Features

- Comply with ITU-T G.991.2 and ETSI TS 101 524 standard
- Symmetric high-speed data access over single-pair copper wires
- Using TCPAM technology to provide multi-speed full duplex transmission, from 192 to 2312 kbps
- High performance to reach long distance, without a repeater for approximately 7km (maximum)
- The best cost-effective solution for replacing T1/E1 leased line
- HTC-4100 Provides various optional E1/V.35/Ethernet network interface of DTE for flexible application
- Fault, performance, configuration, and security management provided
- Safe-test, loopback and QRSS testing features for on-site trouble shooting

G.SHDSL Specifications	
<u>G.SHDSL Card for HTC-1100E (SHDSL-XCVR)</u>	
Port density:	1port per line card
Management:	LED indicators
Dimension:	5.125 x 10.5 x 0.563
Loop connection:	Wire wrap pins
Loop Interface	
Number of wire:	Two wires
Standard:	Comply ITU-G.991.2 Annex A and B
Line impedance:	135 ohms
Transmission distance:	4.1~7.1km (0.4mm wire)
<u>G.SHDSL Standalone Unit (HTC-4100)</u>	
Number of G.SHDSL lines:	One line per unit
Network interface:	Ethernet, V.35, and E1; EIA-530, RS-449 and X.21 needs conversion cable
Management: LED indicator:	Power, DSL, Link, Test, CPE, and Alarm CID (RS-232)
Power requirement:	110 ~ 240 VAC
Dimension:	35mm x 210mm x193mm
Loop connection:	RJ-48 (Fully compatible with RJ-45)
Loop Interface	
Number of wire:	Two wires
Standard:	Comply ITU-G.991.2 Annex A and B
Line impedance:	135 ohms
Transmission distance:	4.1~7.1km (0.4mm wire)
Ethernet	
Bridge support:	4K-hash table
Payload rate:	N x 64kbps, N<36
Connector:	RJ-45

G.SHDSL Specifications

G.SHDSL Standalone Unit (HTC-4100)

V.35 Interface

Data rate: N x 64kbps, N<36
Clock source: Internal, DSL or DTE
Connector/Role: ISO-2593 female/DCE

E1 Interface

Line code/interface: HDB3/ITU-T G.703, 2.048 MB/s
Frame format: Framed and transparent
Payload rate: N x 64kbps, N<31
Line impedance & connector: DB 15 pin for 100 ohms, BNC for 75 ohms

Environment

Storage Temperature: -40°C ~60°C
Storage Humidity: up to 98% at 35°C
Operating Temperature: 0 ~60
Operating Temperature: 0 ~60
Operating Humidity: 5%-95%, none condense

Maintenance

V.54 remote loopback: Built-in
QRSS pattern generator: Built-in

1 Introduction

The HTC-1100E is a modern, flexible Digital Loop Carrier (DLC) system. The HTC-1100E utilizes a modular building block approach to provide services in a wide range of network topologies using a variety of transmission media. It is capable of serving from as few as six to more than one thousand subscribers economically.

The HTC -1100E's advanced; high-density architecture makes it an ideal digital loop carrier for current as well as future applications. It is perfect for new growth deployments, or upgrades to existing service in urban, suburban and rural environments.

The HTC-1100E System meets applicable ETSI /ITU-T international requirements. It is compatible with older electromechanical exchanges and the modern electronic and digital exchanges and Y2K bug free.

1.1 Key Features

- Comply with ITU-T/ETSI Standards for transmission and voice interface
- In compliance with ITU-T G.965 V5.2 interface (IDLC)
- V5 is compatible to major switch vendors
- Capable of economically serving from 6 to 672 non-blocking channels --- "Pay as you grow"
- Providing Automatic Concentration between terminals that enables the System to have 2,000 lines capacity; 64km fiber-span between two terminals
- Integrated analog and digital services
- POTS, Payphone, 2W/4W E&M, ISDN ("U" interface)
- E1/FE1 (G.703), Nx64k (V.35/V.36)
- VDSL/ADSL (mini DSLAM)
- IDSL, HDSL, G.SHDSL
- Variety of transmission media can be used -G.703 E1, HDSL (ETSI), Fiber (49M), STM-1
- Redundant CPU and transport module come with manual and automatic protection switching; redundant power supply for load sharing and backup
- Plug-and-play design; automatic alarm reporting with visual and audio alert; advanced self-diagnostics

1.2 System Design

The design of the HTC-1100E is based on the following fundamental principle: The configuration and capabilities of a advanced digital subscriber carrier system should be dictated by customers' network and service requirements. Holding to this principle, the designers of the HTC-1100E have created a digital subscriber carrier capable of fitting into diverse networks and utilizing various transport media in a virtually limitless number of configurations.

HTC-1100E uses time division multiplexing(TDM) and pulse code modulation(PCM) technology by E1 or fibber carrier. The location communication (LC) and remote communication (RC) dispatch the timeslots of resource by CCS, and the signalling transmits by CAS.

The HTC-1100E is compact and versatile, easy to install, easy to use, and easy to maintain. The high density of the HTC-1100E makes it a natural for urban environments where space is at premium in either the local exchange building, the remote site building or the Controlled Environmental Vault (CEV).

The HTC-1100E terminals are composed of one or multiple twenty-six-slotted Channel Bank Assemblies (CBA). Each CBA consists of two Central Processing Unit slots, two Power Supply Unit slots, and twenty-two general purpose card slots on a 98 Mbps backplane. Several unique features are incorporated into the CBA, making it exceptionally flexible and cost-effective:

- Each CBA shelf provides both common control and distribution of services. This eliminates the need for a separate common control shelf and makes a lower start-up costs.

- Any service card may be plugged into any general purpose card slot by clasp for easily unplugging. All cards designed for the HTC-1100E are the same physical size, from the six channel (64 Kbps per channel) POTS card to the 50 Mbps Fiber Optic Transceiver card.
- The HTC-1100E CBA is truly "universal." The identical CBA is utilized at both the Central Office and remote sites. This feature allows the customer to re-deploy any CBA from one site to another, regardless the environmental and functional requirements.

1.3 System Expansion

Expansion of the HTC-1100E is accomplished simply by adding one or more CBA's linked to the primary shelf by fiber optic cables. Each HTC-1100E system may be configured up to 672 channels of 64 Kbps, or a maximum of eight CBA's.

1.4 System Elements

The HTC-1100E system is designed with a unique and flexible architecture to provide advanced service capabilities and cost effectiveness over a broad range of line sizes. Various configurations of the basic elements can be used to provide POTS and enhanced telephone services over fiber, and E1 transport media. The services may be provisioned utilizing Point-To-Point, Star, Drop & Insert, and Tree & Branch configuration. The V5 interface for integrated configuration is under development and will be released in the near future.

All the HTC-1100E elements have been thoroughly designed. The plug-in units contain no hardware strapping requirements, since most options are software-programmable from the HTC-1100E Craft Interface. All the HTC-1100E plug-in units and assemblies are environmentally hardened to withstand harsh environments. Each of the HTC-1100E basic elements is described in details below.

1.4.1 Local Exchange Terminal (LET)

The HTC-1100E LET is normally located in the Central Office (CO). In the universal configuration the LET provides interface to the Local Exchange Switch as well as the links to Remote Subscriber Terminals (RST). The LET also provides Craft Interface, the software controls, and alarm connections. Each LET can support as many as 672 subscribers distributed among 15 RST's in various network architectures. The LET consists of up to eight CBAs. Subscriber services may consist of any combination of POTS, Payphone, Ground Start, Loop Start, E&M(for 2 Wire and 4 Wire application) , E1, digital (ex: ISDN, IDSL etc.) or analog data, and others. The electronic protection of any cards complies with IEC 1000-4-5 Class 2.

1.4.2 Remote Subscriber Terminal (RST)

The HTC-1100E RST is located in customer service area. The RST may be linked to other RSTs, a LET, or directly to the CO switch, depending on the requirements of a particular application.

Any RST may be rack-mounted inside a remote switch building or a CEV. The RSTs may also be built into an indoor cabinet and placed inside a telephone utilities building, or inside a subscriber's office building. Finally, they may be also configured as outside plant facilities in a environmentally sealed and hardened outdoor cabinet.

1.5 Remote Subscriber Cabinet

The HTC-1100E Remote Subscriber Cabinet (RSC/240-360 and RSC/480-600), pad mounted, can accommodate two CBA's in a cabinet to provides up to 240-360 lines of capacity or four CBA's in a cabinet to provides up to 480-600-600 lines of capacity. The HTC-1100E cabinet has the modern design and are environmentally hardened and sealed in order to protect the equipment inside.

1.6 Transport Media Options

The HTC-1100E's flexibility allows users to make decisions in network planning based on existing and future network architecture requirements and transport media availability, rather than on the limitations normally associated with a DLC.

The following sections describe the various transport media a customer may choose from when deploying The HTC-1100E without changing any wire routing on the backplane.

1.6.1 Fiber Optic Transport

The HTC-1100E is designed to efficiently utilize fiber optic cable as the transport medium. The HTC-1100E terminals can be easily configured for redundant (four-fiber span) or non-redundant (two-fiber span) applications.

With integrated fiber multiplexing capabilities, the HTC-1100E does not require a separate fiber multiplexer to provide services via optical fibers.

While the HTC-1100E's fiber transceivers (FO/FOW -XCVR) provide a 49.152 Mbps optical link, the SDH -XCVR provides a 155.52 Mbps optical link. These transceivers all allow non-blocking transport of all services deployed from any HTC-1100E terminal.

Upgrades from copper to fiber facilities can be accomplished by the simple replacement of any existing HTC-1100E E1 cards with fiber transceiver cards. The conversion is quick, easy, and inexpensive. Most importantly, it does not affect customers in service, regardless whether they are on or off-hook.

1.6.2 E1 Transport

The HTC-1100E is compatible with all types of E1 transport media.

Repeatered copper facilities may be utilized by assigning E1 spans as the transport medium between any HTC-1100E terminals. Environmentally hardened, line powered HTC-1100E E1 transceivers are available to power repeaters and to provide sealing current.

Non-repeatered HDSL E1 spans may be used in place of repeatered E1s wherever the opportunity exists. HDSL transceiver cards have been developed as a plug-in option for the HTC-1100E.

E1 microwave radios may also be utilized to transport to and from any HTC-1100E terminal. Non-line-powering, plug-in E1 transceivers are available for all DSX applications.

The HTC-1100E allows flexible concentration of traffic over E1 facilities for all types of HTC-1100E E1 transceivers.

High traffic applications, such as business centers, may be served via non-concentrated E1 facilities to maintain non-blocking service even during peak business hours. Protection spans may be added at the customer's discretion.

Lower traffic volume locations, such as suburban or rural residential areas, may be configured with fewer E1 spans, providing any desired level of traffic concentration.

In all cases, employing multiple spans provides protection against span failures, since traffic will be automatically rerouted by HTC-1100E from faulted spans to functional ones.

1.7 Network Architecture Options

The HTC-1100E's ability to utilize various transport media is enhanced by its ability to integrate itself into any Network Architecture. Universal, Star, Drop & Insert, and Tree & Branch configurations are all supported by HTC-1100E's flexible design.

HTC-1100E System Description

The HTC-1100E's built in I/O time slot interchanger allows the system to act as a digital cross connect. Any HTC-1100E terminal may be utilized to transport interoffice facilities, deliver subscriber services, or do both simultaneously. The HTC-1100E may also be deployed as a stand alone channel bank to accept, groom and deliver services to and from other network elements.

Another unique application of HTC-1100E is as a standard fiber multiplexer delivering up to 28 E1's over fiber facilities. 20 E1's may be delivered from a single 19" HTC-1100E Channel Bank Assembly in this type of application. Following are descriptions of several HTC-1100E Network Architecture options accompanied by illustrations.

1.7.1 Universal Configurations

Figure 1-1 shows a Point-to-Point Universal HTC-1100E configuration. Large or small groups of subscribers may be served from HTC-1100E in the traditional universal digital loop carrier topology.

In this configuration, the Local Exchange Terminal is collocated with the CO switch. Various services are provided from the Remote Subscriber Terminal, which is located in a remote cabinet, rack mounted in a CEV, or on a subscriber's premises.

Various transport media may be chosen to provide the interface between the LET and RST.

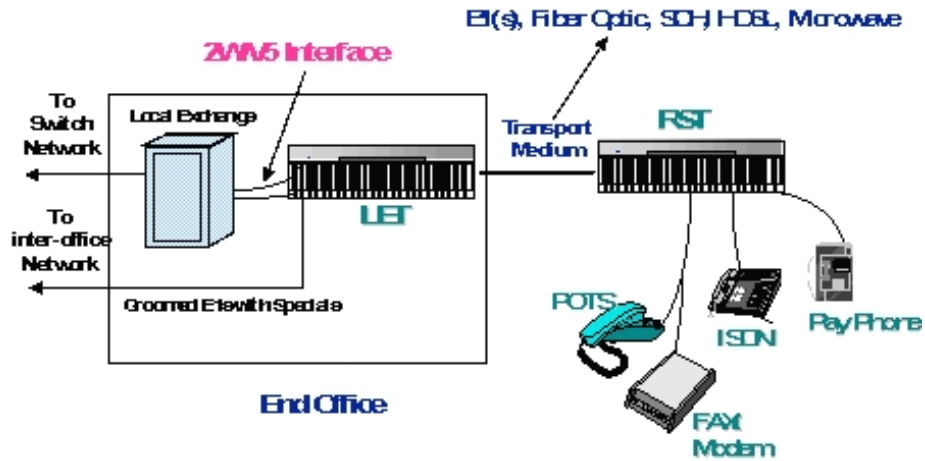

Figure 1-1 Point-to-Point Universal Configuration

1.7.2 Star Configurations

Figure 1-2 shows an example of Star configuration. Up to four (4) RSTs may be homed directly to an LET or to another RST in a Star configuration.

Transport media; from the LET to the RSTs in this example include fiber, analog, and E1 facilities.

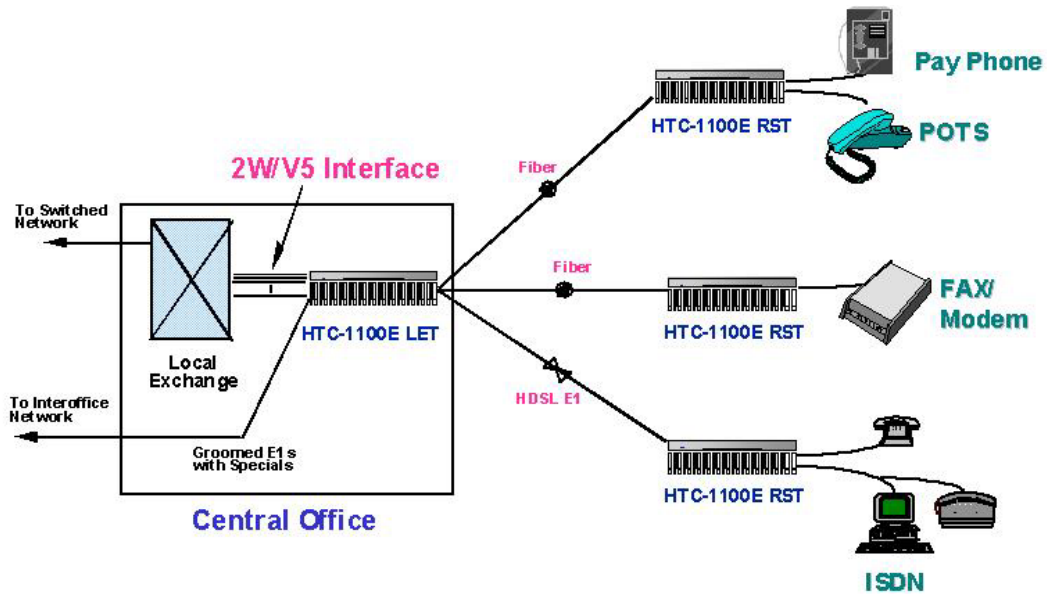

Figure 1-2 Star Configuration

1.7.3 Drop & Insert Configurations

Up to five (5) RSTs may be cascaded in a Drop & Insert configuration. Several transport media may be utilized from one terminal to the next in a Drop & Insert configuration. Figure 1-3 shows a sample Drop & Insert configuration.

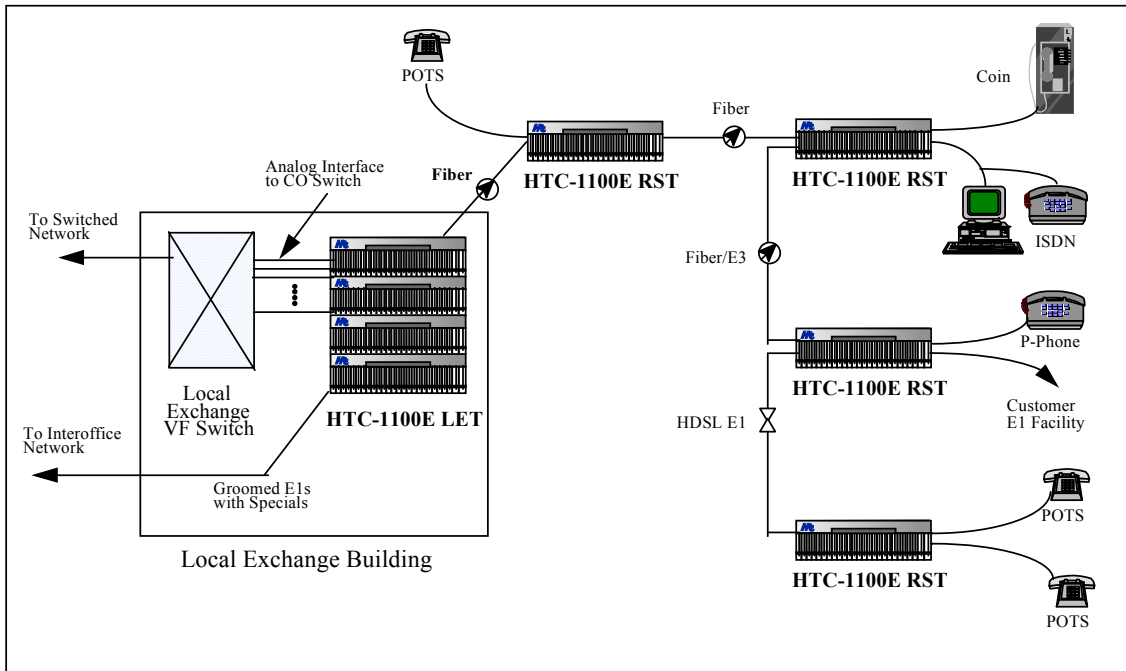

Figure 1-3 Drop & Insert Configuration

1.7.4 Tree & Branch Configurations

Figure 1-4 shows a sample Tree & Branch configuration. The HTC-1100E may be seamlessly integrated into networks of this type.

One of the RSTs in this illustration is served over fiber from an RST interfaced to the LET via copper. This demonstrates HTC-1100E's adaptability to the requirements of a service area.

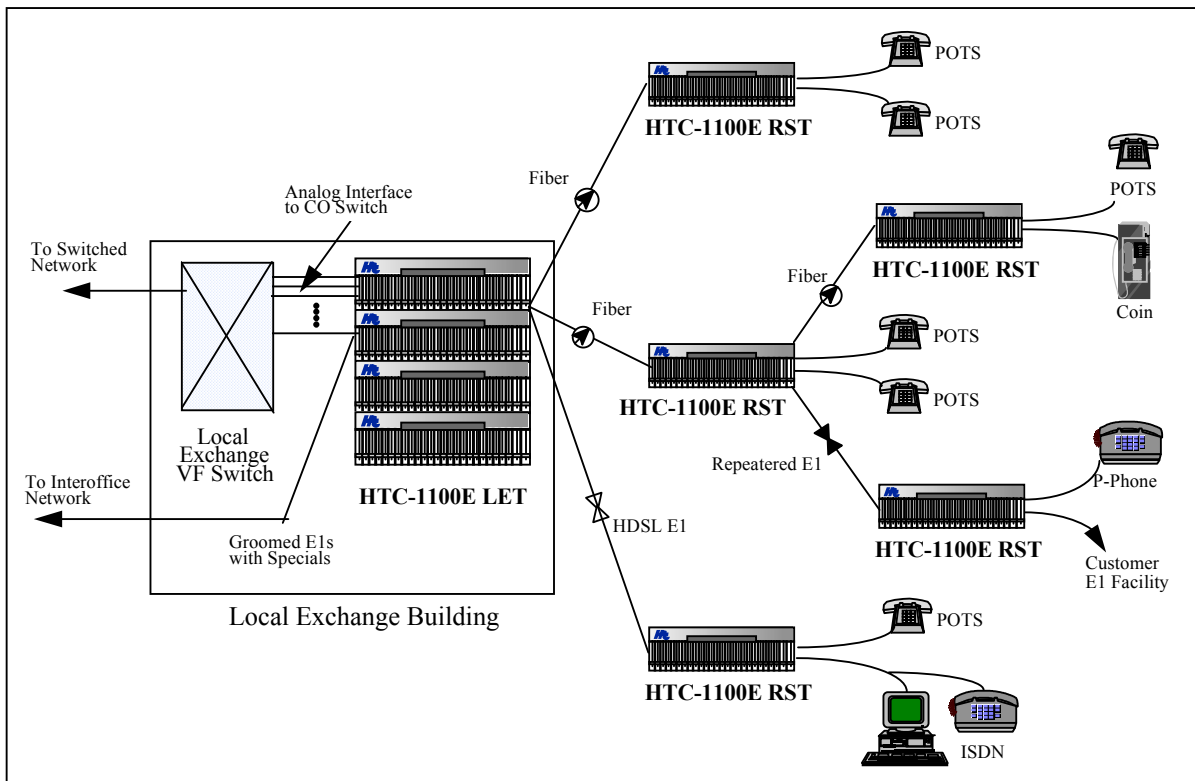

Figure 1-4 Tree & Branch Configuration

1.7.5 Enhanced Integrated Interface Configurations

Figure 1-5 shows a configuration of utilizing V5.1 or V5.2 interface. This demonstrates how the LET is used to groom specials for the inter-office network, to interface with fiber-fed RST's, and to integrate POTS into V5 interfaces for maximum efficiency.

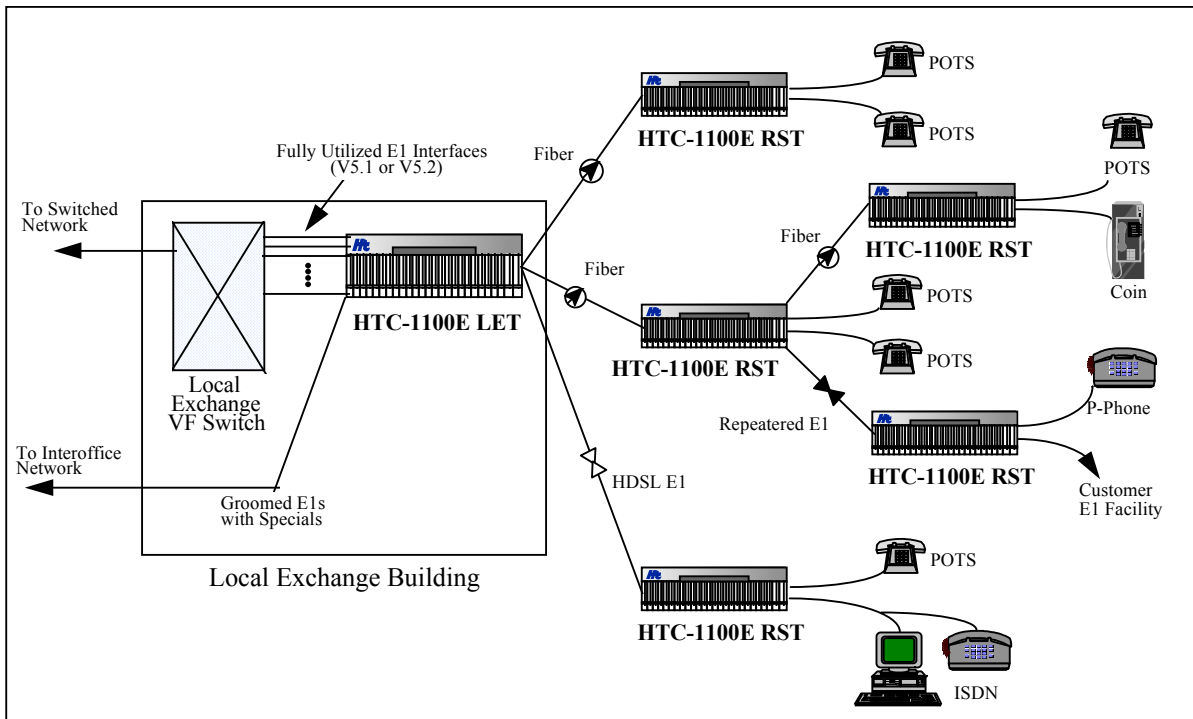
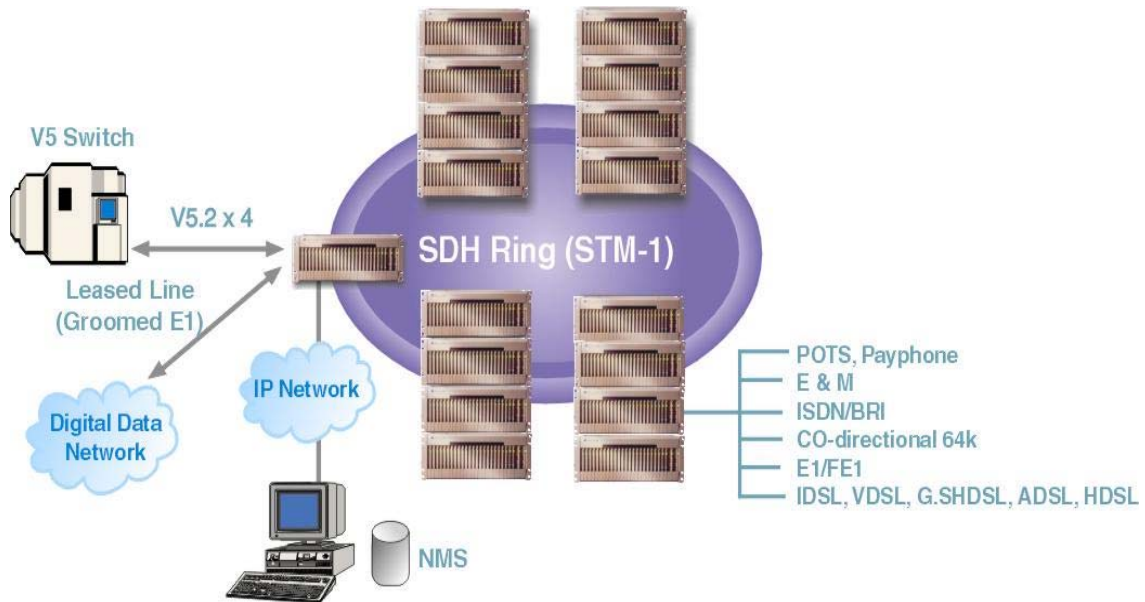

Figure 1-5 Enhanced Integrated Interface Configuration

1.7.6 Ring Configurations

Figure 1-6 shows a ring configuration of utilizing SDH-XCVR transceiver. HTC-1100E can provide resilient configuration that allows operator provide proven network services based on ring topology.



1.8 Subscriber Loop Testing Capabilities

Advanced and comprehensive loop testing capabilities are available from any HTC-1100E RST.

Tests may be accomplished using the HTC-1100E Metallic Test Unit (MTU) or Analog Test Unit (ATU). The MTU/ATU has been designed specifically for HTC-1100E terminals as a plug-in option and integrated into the HTC-1100E Craft Interface (described in Section 1.8).

HITRON has also worked with various manufacturers of industry standard loop testing protocols which may be integrated into HTC-1100E LET and any HTC-1100E RSTs.

See Section 4 Unit Description and Specification for more details of the HTC-1100E MTU and ATU.

1.9 Craft Interface & Alarm Capabilities

The HTC-1100E Craft Interface is simple to use and provides menu-driven and command mode. It may be accessed from either the LET or any RST, using either a dumb terminal or a terminal emulation program on a PC. It is also possible to use modems for dialing up and polling RSTs. Any visual display unit can communicate with HTC-1100E through the RS232-C connector located on each HTC-1100E Channel Bank Assembly.

The HTC-1100E utilizes a data link between terminals. Each transmission span carries an inter-terminal data link in addition to communication channels. The data link is used for communication channel allocation, provisioning, maintenance, traffic statistics, testing, and administration messages. Communications channels are allocated on a call-by-call basis. Full data link and communication channel redundancy is achieved by equipping multiple interface spans.

The HTC-1100E Craft Interface allows provisioning, maintenance, traffic monitoring, testing, and administrative activities to be performed quickly and easily.

The Craft Interface Provisioning Menu allows the user to perform system turn-up functions, such as timing source selection, system configuration customization, and transceiver and circuit settings selection.

The HTC-1100E Craft Interface includes a Maintenance Menu, which allows: alarm threshold configuration, alarm report when crossing threshold, alarm retrieval, remote alarm cutoff, retrieval of alarm history, and performance monitoring.

The Craft Interface Testing Menu allows access to the built-in testing functions of the HTC-1100E. The testing options include a variety of software diagnostic tests, LED tests, as well as loopback capabilities. The administrative functions include setting the data and time and user security, such as adding, changing, or removing of user IDs and passwords.

In addition, all HTC-1100E transceiver, CPU, service, and power cards are equipped with status LEDs, allowing many maintenance functions to be performed without the need for a visual display terminal. Relay contact closures are provided for system alarm monitoring interfaces. Where appropriate, jack access is provided on the front of the circuit packs to provide access to tip/ring pairs, service clocks, and battery voltages. The Metallic Test Unit (MTU) or ATU (Analog Test Unit) provides tip/ring access to automated test systems.

The alarm contacts are wired to relays in the FAA backplane. They are classified as Critical Visual, Major Visual, Minor Visual, Audible, Fail-Safe, Near-End and Far-End.

An Alarm Cut-Off(ACO) button is provided on the CPU card faceplate, and an Alarm Cut-Off command is provided in the craft interface. The ACO silences the audible alarm and reset of the record of the system configuration in the system memory in order to activate audible alarm again when new alarm coming

For outdoor cabinet, the external alarm could be generated by the following conditions: open cabinet door (Front and Rear), AC failure and over temperature and so on.

Figure 1-6 shows the Craft Interface Main Menu. All functions of the HTC-1100E Craft Interface are designed to be easily accessible from sub-menus similar to the Main Menu.

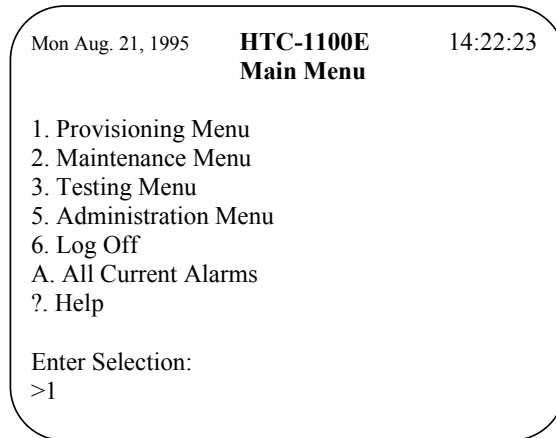

Figure 1-6 Craft Interface Main Menu

1.10 Network Management Interface

HTC-1100E provides network management interface to allow GUI remote access via Ethernet network. The network management is developed base on SNMP protocol compliant to be installed on Windows PC system as operation platform (working on AC 110+-10V, 60 +-3Hz power supply).

The interface also shows the whole data for user's retrieving, provisioning and display what craft interface does for the system.

The Element Management System (EMS) can provide user password administration, retrieval and configuration of data access privilege level in order to maintain the system database security.

HTC-1100E has build-in non-volatile memory for backup system configurations and alarms.

HTC-1100E's Element Management System can be built upon any industrial management platform such as HP OpenView. HTC-1100E's EMS (Element Management System) can be customized to meet any operators existing management protocols via industrial standard management platform should any inquiries arise. For example, HTC-1100E's EMS can be interoperable with operator's 112 (telephone fault reporting hotline) system. The EMS can exercise an extensive loop test capacity via system's ATU (Analog Testing Unit) cards inserted in LET & RST. This enhanced loop testing features would facilitate easy system operation and interoperability.

1.11 Provisioning

HTC-1100E has the following provisioning for system operation convenience via craft interface and network management interface

1.12 Network Equipment Data Administration

Configure and retrieve the system ID, software version, synchronization timing source and service status. Retrieve operational status and operating capacity status.

1.13 Provisioning Network Equipment

Retrieve plug-in slots and cards of the HTC-1100E system, including of user settings of cards and the service status of the plug-in cards and showing the slot numbers and their corresponding plug-in cards.

1.14 Digital Transmission Equipment Provisioning

Retrieve and configure the transmission parameters, service conditions of digital transmission equipment.

1.15 User Access Port Provisioning

Retrieve and configure the plug-in card, port and grooming information on service condition of the card in service.

1.16 Conclusion

A high level of integration combined with a flexible, software-driven architecture, allow the HTC-1100E System

HTC-1100E System Description

an economical and powerful digital loop carrier system. The HTC-1100E meets all of the needs of a local loop, whether the subscriber environment is urban, suburban, or rural, whether the service is business or residential, and whether the service is provided by new or existing facilities.

Via craft interface and network management interface, the operator can retrieve alarm status and configure alarm classification.

In summary, the modular building block approach and powerful software-driven provisioning system of HTC-1100E enable custom system topologies to be easily engineered. The HTC-1100E has been designed to fit seamlessly into any network, and economically provide high technology solutions for a limitless number of applications.

2 System Description

This section describes the HTC-1100E system and each of its component parts, including System Terminals, System Topologies, Common Control Features, Powering Options, Transceiver Options, Subscriber Services, Assemblies and Cabinets, Common Control Units, Transceivers, Channel Units, Craft Interface, and Testing Capabilities.

2.1 System Terminals

HTC-1100E consists of two terminal elements, the Local Exchange Terminal (LET) and the Remote Subscriber Terminal (RST). The fundamental building block for the system is the 19-inch (48.3-cm) wide by 7-inch (17.8-cm) tall shelf, Channel Bank Assembly (CBA), as shown in Figure 2-1 below.

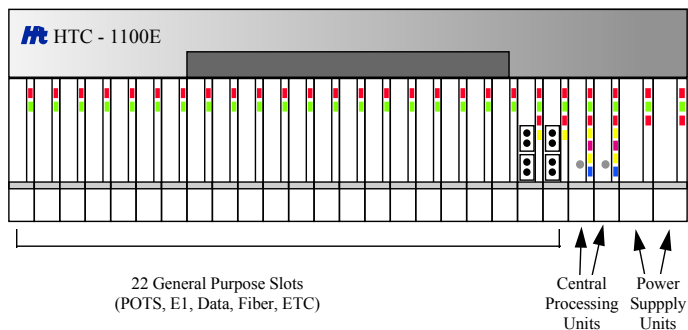

Figure 2-1 HTC-1100E Channel Bank Assembly

The LET consists of up to eight CBAs. The first CBA is always configured as the Primary and the additional ones configured as Expansions. All expansion shelves in each system are connected via fiber optic cables to the Primary shelf.

Each shelf contains a total of 26 slots for the installation of Power Supply Units, Central Processing Units, and diverse combinations of channel units, expansion cards, and transceiver units, as required for a particular application. (See Figure 2-2). The blank faceplane with PCB is provided for dust-free.

An RST, like the LET, may be composed of up to eight CBAs. The remote terminals may be rack-mounted on a customer premise or in an environment-controlled vault.

The various components of HTC-1100E System are described as below. More detailed descriptions of all HTC-1100E components, including technical specifications, are provided in Section 4.

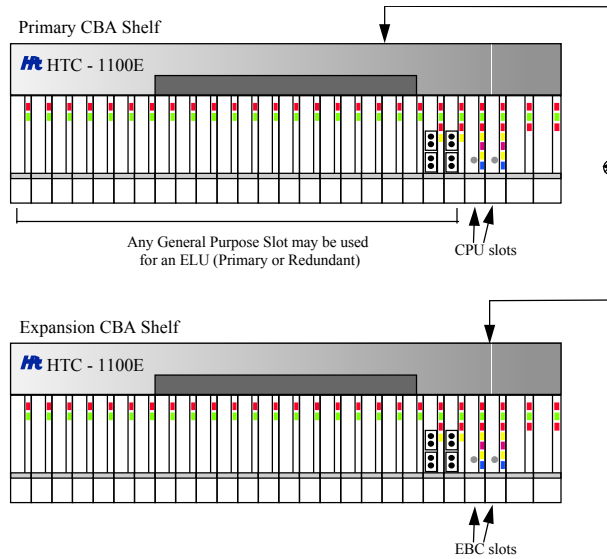

Figure 2-2 Primary and Expansion CBAs

2.2 Assemblies & Housings

For convenience, HITRON has designed a number of assemblies to assist in field installation of HTC-1100E equipment.

2.2.1 CBA

The Channel Bank Assembly (CBA) consists of pre-formed cold-rolled steel, powder coated card cage, metal rear covers, printed circuit board back panel, and mounting hardware. The CBA contains all the hardware necessary for installation, except cables for voice, data and power. The CBA includes the Air Ramp to facilitate the convection cooling of the system as well as to provide fiber routing function. It also houses the RS232-C Craft Interface, Order Wire Connection, and Electro-Static Discharge (ESD) jacks. Identical CBAs are used in both the LET and RST and can be configured as a Primary or Expansion shelf.

Alarm scanning inputs are provided on CBA back panel for connecting to external alarm detectors or FAA(Fuse and Alarm Assembly). In remote cabinets, door alarms, temperature alarms, battery charger and AC failure alarms may be connected to an RST for relay back to the LET. Two miscellaneous alarms are available for custom applications. The LET terminal outputs these alarm using dry relay contacts.

2.2.2 FAA

The Fuse and Alarm Assembly (FAA) provides fusing for the A and B battery feeds. Office Alarm contact points are also provided via the LED indicators displaying system alarm status on the front panel of FAA. The FAA also provides a wire wrap field where multiple alarm points may be wired from the systems in the rack to central alarm device. These include major, minor, minor audible and visual alarms.

2.2.3 RSC/240-360

The 240-360 Line Remote Subscriber Cabinet (RSC/ 240-360) is an environment-sealed, aluminum-powder-coated enclosure, equipped to house up to two CBAs for a total capacity of 240-360 subscriber lines. Sealed 48V battery strings provide 8 to 12 hours of backup for the RSC/240-360 equipment. Front and rear doors are provided for easy access. The RSC/240-360 has been designed with protector blocks, cable termination area, fiber splice trays and storage, local AC power meter, AC service connection, as well as many other remote terminal necessities. Options include integrated cross connect for OSP cable; lightning protectors; and multiple base heights. RSC/240-360 uses a dual shell, heat exchanger approach to maintain internal temperatures. The RSC/240-360 is designed for pedestal mounting on a pre-cast concrete or fiberglass pad.

The RSC/240-360 is powered via rectifier (220 volt AC) with battery backup. The sealed battery is water-resistant, maintenance-free and to be full-charged mode. It has to be in-charge dc mode when working normally. Emergency generator connections are available for the RSC/240-360 as an option. A 110-volt AC power entrance is also available as an option. The rectifier should be shutdown when voltage below -42 volt.

2.2.4 RSC/480-600

The RSC/480-600 enclosure is constructed of 1/8" powder coated aluminum. The cabinet is cooled by utilizing a double wall heat exchanger in addition to DC powered fans. The heat exchanger allows air to circulate between the inner and outer walls allowing HTC-1100E equipment compartment to maintain a favorable temperature range, even during the most inclement weather. The DC powered fan is immune to AC power failures. The combination of these design features provides HTC-1100E equipment with a technologically advanced sealed enclosure, and prevents contaminants from entering the equipment area.

The RSC/480-600 may be equipped with 48V battery strings, which provide 8-12 hours backup capacity. The battery tray is located in the bottom of the cabinet. Battery Heaters/Air Conditions are available for use in regions with different climates.

2.2.5 RSC/1000

The RSC/480-600 enclosure is constructed of 1/8" powder coated aluminum. The cabinet is cooled by utilizing a double wall heat exchanger in addition to DC powered fans. The heat exchanger allows air to circulate between the inner and outer walls allowing HTC-1100E equipment compartment to maintain a favorable temperature range, even during the most inclement weather. The DC powered fan is immune to AC power failures. The combination of these design features provides HTC-1100E equipment with a technologically advanced sealed enclosure, and prevents contaminants from entering the equipment area.

The RSC/1000 may be equipped with 48V battery strings, which provide 8-12 hours backup capacity. The battery tray is located in the bottom of the cabinet. Battery Heaters/Air Conditions are available for use in regions with different climates.

2.3 Common Control Units

HTC-1100E System uses a distributed common control architecture which economically provides advanced digital loop carrier features across a wide range of line sizes.

The system is microprocessor controlled, enabling it to be flexible and adaptable to new environments. At the heart of the system is a 768 port time slot switching matrix allowing for 672 non-blocking service ports plus timing control and other overhead. Since all plug-in units employ micro-controllers, all units provide non-volatile storage of card-specific data like serial numbers, software/hardware versions and manufacturing date codes. This allows HTC-1100E to retrieve the status of any assembly and determine its compatibility for a given system configuration.

The following lists the common control units for HTC-1100E System.

- Central Processing Unit (CPU)
- Expansion Bank Control (EBC)
- Expansion Link Unit (ELU)
- LET Power Supply Unit (L-PSU)
- RST Power Supply Unit (R-PSU)
- Metallic Test Unit (MTU)

2.3.1 CPU

The Central Processing Unit (CPU) contains a microprocessor-based computer which is responsible for the overall control of HTC-1100E System. Installed in the LET and RST primary CBA, the CPU contains on-board non-volatile program, data storage, and run-time memory. It also contains the system timing circuitry, along with circuitry to provide data link support for intra-terminal communication. The software of CPU performs system initialization, call processing, alarm reporting, redundancy audits, and run-time diagnostics. It also drives the local Craft Interface ports, which include provisioning, maintenance, traffic monitoring, testing, and administration features. Additional CPU can be applied as a redundancy.

2.3.2 EBC

The Expansion Bank Control (EBC) provides the microprocessor-based control for an expansion shelf. It provides the interface to the system for each transceiver and service card in the expansion shelf via a fiber optic connection to the corresponding Expansion Link Unit in the primary shelf. The EBC resides in the expansion shelf in card slot No. 23 or 24, which is utilized by the CPU in the primary shelf. Redundancy is possible simply by utilizing dual EBCs as with the CPU.

2.3.3 ELU

The Expansion Link Unit (ELU) provides the system connection from the primary shelf to each expansion shelf. One ELU is connected via fiber optic facility to each EBC in an expansion shelf. The ELU transmits system features from the CPU to its dedicated expansion shelf, and receives information from an EBC and relays it to the CPU. The ELU may reside in any of the 22 general-purpose slots in the primary shelf. Redundancy is possible by utilizing dual ELUs.

2.3.4 L-PSU

The LET Power Supply Unit (L-PSU) converts the office battery (-42 VDC to -63 VDC, nominal: -48VDC) input to the voltages required by the common equipment and line cards installed at the LET. A single L-PSU is built in

card slot No. 25 or 26 to power a CBA. Redundancy with load sharing functions is possible by utilizing dual L-PSUs.

2.3.5 R-PSU

The RST Power Supply Unit (R-PSU) converts the rectifier input (-42 VDC to -63 VDC, nominal: -48VDC) to the voltages required by the common equipment and line cards installed at the RST. In addition, the R-PSU also generates sine wave ringing voltage for use by the subscriber interfaces. A single R-PSU is plug in card slot No. 25 or 26 to power a CBA. Optional redundancy with load sharing functions is recommended by utilizing dual R-PSUs.

2.3.6 MTU

The Metallic Test Unit (MTU) provides HTC-1100E with enhanced testing and diagnostic capabilities. The MTU is used to test outdoor cables and has the capacity to test all channel units at an RST. It provides basic metallic access, a remote line test head, and extensive internal diagnostic measurement capabilities. The MTU, an optional plug-in card, eliminates the need for a remote test head. It can be installed in any of the 22 general-purpose slots, normally in RST.

2.3.7 ATU

The Analog Test Unit (ATU) provides HTC-1100E with enhanced testing and diagnostic capabilities can be used to test outdoor drop and has the capacity to test all channel units at an RST. It also provide the inner test to check the transmission paths from Exchange to LET or LET to RST while ATUs are inserted in both LET and RST. It provides basic metallic access, a remote line test head, and extensive internal diagnostic measurement capabilities. It can be installed in any of the 22 general-purpose slots, normally in LET and RST.

2.3.8 NMI

The Network Management Interface (NMI) is a plug-in card inserted in the LET of HTC-1100E that serves as the physical network interface providing a 10/100Base-T connection as well as a agent of EMS (Element Management System). The protocol of communication is TCP/IP and SNMP. The NMS sends requests encoded in SNMP format to NMI. The NMI transfers the request to CPU. In another way, CPU send response to NMI, and the NMI transfer the message to NMS. Via NMI and EMS, The NMS can autonomously detect the HTC-1100E network topologies and graphically display equipments in a tree-like fashion. Each leaves in the tree represents the DLC equipment, which facilitates easy local and remote network management.

2.3.9 E3X-XCVR

The E3 Transceiver (E3X-XCVR) provides an E3 rate interface at a G.703 signaling level, transmitting and receiving up to 480 basic 64 Kbps channels of voice or data originating from the channel units in the subscriber slots. It operates at E3 rate of 34.368 Mbps. This transceiver is designed to interface with other multiplex equipment. The E3X-XCVR transceiver has selectable alarm thresholds, BER calculation, performance monitoring, and alarm history. An optional second E3X-XCVR provides span redundancy. If an E3X-XCVR facility fails, services are automatically routed over the other E3X-XCVR or Fiber Optic Transceiver if it has been installed.

2.4 Transceivers

The HTC-1100E transceivers provide the link between two RSTs , or between an RST and an LET. Any general-purpose slot of the primary CBA (whether in LET or RST) may be provisioned with repeatered E1, HDSL E1, or fiber transceiver cards. The number of transceivers used at any terminal depends on the application. Many factors, including number of lines, transmission media, desired level of service concentration (where applicable), and whether or not protection (redundancy) is desired, will determine the ultimate number transceivers needed.

HTC-1100E can support transceiver 1+1 protection. It will auto switching from activating trunk to standby trunk when the activating trunk is fail or lost. The talking which is taking place will not be infected when the protection switching happen.

The system operator may specify the bit error rate where specific alarms are to be reported. The BER(bit error rate) calculated for each end of the transmission span on the receive data.

Table 2-1 shows a complete list of HTC-1100E transceivers. Six transceivers have been designed for HTC-1100E System. The E1 transceivers (E1-XCVR & E1X-XCVR) each support one E1 circuit per card. The HDSL transceiver is used to extended transmission distance of E1X-XCVR. The fiber optic transceivers (FO-XCVR & FOW-XCVR&SDH-XCVR) may be employed by utilizing optical fibers for interconnection between terminals.

Table 2-1: Transceiver Options for the HTC-1100E

Transceiver	Part Name	Facilities	Number of Channels
E1 (powered)	E1-XCVR	1 E1 Facility	30
E1 (non-powered)	E1X-XCVR	1 E1 Facility	30
HDSL	HLC-XCVR (for LET) HLR-XCVR (for RST)	1 HDSL Facility	30
Fiber Optic	FO-XCVR FOW-XCVR SDH-XCVR	2 Fibers	Up to 1000 Up to 3000

Note: All transceiver options may be used at either the Local Exchange Terminal or Remote Subscriber Terminal, except HLC-XCVR and HLR-XCVR shall be located at LET and RST, respectively.

2.4.1 Line Powering E1-XCVR

The Line Powering E1 Transceiver (E1-XCVR) provides E1 rate interface, transmitting and receiving up to thirty DS0 channels of voice or data, originating from either the channel units or another transceiver. It operated at the rate of 2.048 Mbps. The E1-XCVR performs signaling conversion and data link termination. It has a power feed system (60 mA constant current source) to power line repeaters in any of the power feed options. These include end-to-end, midspan or span terminating (sink) powering configurations.

Each transceiver provides thirty 64 Kbps timeslots per span along with their associated signaling channels, datalink, and span overhead bandwidth. Multiple E1 transceivers may be utilized by any RST, up to the limits of the HTC-1100E backplane, to obtain a desired concentration level. All subscriber services at a remote terminal have access to all E1s at that remote. If an E1 facility fails between two HTC-1100E terminals, services are automatically routed to remaining E1s.

2.4.2 E1X-XCVR

The HTC-1100E E1 Transceiver (E1X-XCVR) provides an E1 rate interface at a G.703 signaling level, transmitting and receiving up to 30 DS0 channels of voice and data, originating from either the channel units or another transceiver. The E1X-XCVR is designed to interface with other multiplex equipment, which also utilizes G.703 signaling, or for the applications where powering of repeaters and sealing current are not necessary, such as short distances inside a central office or at a customer premise.

Like E1-XCVR, each E1X-XCVR transceiver provides thirty 64 Kbps timeslots per span along with their associated signaling channels, datalink, and span overhead bandwidth. Multiple E1 transceivers may be utilized by any RST, up to the limits of the HTC-1100E backplane, to obtain a desired concentration level. All subscriber services at a remote terminal have access to all E1s at that remote. If an E1 facility fails between two HTC-1100E terminals, services are automatically routed to remaining E1s.

2.4.3 HD-XCVR

The HDSL Transceiver (HD-XCVR) utilizes two twisted pairs to transport a full E1 signal. By using 2B1Q line codes, HD-XCVR carries 1,168Kbps data streams over each twisted pairs to have the E1 signal, originated and terminated by E1X-XCVR, been transmitted over an extended distance to 4.2Km @0.5mm without repeaters. It satisfies the demand for users who are in the dilemma of E1 repeaters or a higher level multiplexer. The HD-XCVR must be applied in conjunction with an E1X-XCVR.

2.4.4 FO-XCVR

The Fiber Optic Transceiver (FO-XCVR) interfaces to a single mode fiber span at a proprietary 49.152 Mbps line rate. Both transmitter and receiver are included on a single card, each connecting to a fiber optic cable. The FO-XCVR uses a single mode laser operating at 1,310 nm and a PINFET receiver to allow non-repeated span lengths of 40 Km. In the Drop & Insert configuration, each fiber-driven RST also functions as a signal regenerator allowing for an additional 40Km of non-repeated span. Single mode FC/PC connectors are standard for the FO-XCVR. A single FO-XCVR provides full, non-blocking, non-concentrated service for 672 customers and requires two fiber optic cable spans (transmitting and receiving). An optional second fiber transceiver provides span redundancy over two additional fiber optic spans.

2.4.5 SDH-XCVR

The Synchronous Digital Hierarchy Transceiver (SDH-XCVR) plug-in card provides 155.52 Mbps optical data interface to a single-mode fiber span. It can transmit and receive voice or data originating from channel units in the LET and RSTs or from other E1 transceivers.

2.4.6 FOW-XCVR

The Medium Range Fiber Optic Transceiver (FOW-XCVR) functions as a FO-XCVR except uses a single mode laser operating at 1,550 nm. The FOW-XCVR can be used with FO-XCVR for Wavelength Division Multiplexing (WDM) applications to support transmit and receive paths on a single fiber.

2.5 Analog Channel Units

The HTC-1100E can be provisioned with full range of analog services, placed in any general-purpose slot up to the limit of the CBA slot capacity. In addition, each subscriber slot may access up to 672 transmitting and receiving data timeslots from the HTC-1100E back panel via its time slot matrix. This allows cards with bandwidth requirements from 64 Kbps to a full 2.048 Mbps (e.g. E1), and beyond, to be supported from any card slot.

Table 2-2 in the following pages provides listings of the service types and possible applications for each service card supported by the HTC-1100E. Additional service cards will be introduced as required.

The HTC-1100E Channel units, described below, provide analog voice-grade interfaces for private or public network use. Flexible bandwidth management allows the HTC-1100E to offer services without degradation of adjacent services.

2.5.1 LI-POTS Channel Unit

The Local Exchange International POTS Channel Unit (LI-POTS) provides six trunk-terminating, loop start circuits. The LI-POTS card provides loop start signaling with ring cadence following, and forward disconnect

signaling. It also provides 'floating' universal ringing detection. The LI-POTS card, is installed in an LET, while its counterpart, the RI-POTS card, in an RST. LI-POTS has the function of polarity guard that can protect Tip-Ring reversal.

2.5.2 RI-POTS Channel Unit

The Remote terminal International POTS Channel Unit (RI-POTS) provides six circuits of standard loop start service. The RI-POTS card provides ring cadence following, local ring trip, on-hook transmission, and forward disconnect. RI-POTS has the function of polarity guard that can protect Tip-Ring reversal.

2.5.3 LI-APOTS Channel Unit

The Local Exchange International Advanced POTS Channel Unit (LI-APOTS), like the LI-POTS, provides six trunk terminating, loop start circuits. In addition to those functions of LI-POTS, LI-APOTS card can detect pulse metering (12 KHz or 16 KHz) and battery reversal signalling from exchange, then RI-APOTS simulates exchange to generate the same signalling, for special POTS applications. It is ordinarily installed in the LET, with its counterpart, the RI-APOTS card, in an RST.

2.5.4 RI-APOTS Channel Unit

The Remote terminal International Advanced POTS Channel Unit (RI-APOTS) provides six circuits of standard loop start service with additional pulse metering (12 KHz or 16 KHz) and battery reversal functions when compared to RI-POTS. The RI-APOTS Card receives the pulse metering (12 KHz or 16 KHz) or battery reversal signaling from LI-APOTS, then generates the same signaling to drive the pay phone.

2.5.5 E&M Channel Unit

The E&M Channel Unit is one of the HTC-1100E's Special Services channel units. It provides one or two, two-wire or four-wire, subscriber line circuits. The circuits can be configured for operations in E&M Modes I through V, PLR Modes I and II, Tandem modes I and II, or in DX signaling mode. The E&M Channel Unit also supports DX signaling. It has fixed impedance with provisionable voice frequency gain over a wide range.

2.5.6 LI-EPOTS Channel Unit

The Local Exchange International POTS Channel Unit (LI-EPOTS) provides six trunk-terminating, loop start circuits. The LI-EPOTS card provides loop start signaling with ring cadence following, transmission, and forward disconnect signaling. It also provides 'floating' universal ringing detection. The LI-EPOTS card is installed in an LET, while its counterpart, the RI-POTS card, in an RST. LI-EPOTS has the function of polarity guard that can protect Tip-Ring reversal.

2.5.7 RI-EPOTS Channel Unit

The Remote terminal International Enhanced POTS Channel Unit (RI-EPOTS) is a Remote Subscriber Terminal (RST) loop start counterpart to the loop terminating LI-EPOTS Channel Unit. RI-EPOTS Channel Unit provides extended range (2000 Ohms of loop resistance) POTS service. RI-EPOTS support six circuits of standard loop start service, ring cadence following, local ring trip, on-hook transmission (for Caller ID).

2.5.8 L-UVG Channel Unit SLC-E / DPT

The Local Exchange Terminal Universal Voice Grade (L-UVG) Channel Unit provides six, 2-wire switched analog circuits. The L-UVG is the R-UVG's counterpart and is equipped at the Local Exchange Terminal. The L-UVG card is direct-mapped to the corresponding R-UVG card and establishes six dedicated circuits, thereby reducing the total number of spans that can be concentrated. Ground key and loop start are supported by the UVG Channel Unit. Pulse metering and battery reversal are also supported for pay phone applications. The L-UVG supports precision gain adjustment in 0.1 dB steps over a 12.0 dB range. The L-UVG must be located at the Remote Subscriber Terminal (RST) for Direct Inward Dialing (DID) applications.

NOTE : We have special versions of L-UVG : SLC-E(Subscriber Line Circuit for Exchange) and DPT(Dail Pulse Termination). They are designed for Korea applications. Therefor they can support Korea R2 and Korea D4 signal. The hardware of SLC-E and DPT are the same as L-UVG. Please refer to 4.4.7 L-UVG spec. for the detail electrical features of SLC-E and DPT.

2.5.9 R-UVG Channel Unit SLC-T / DPO

The Remote Subscriber Universal Voice Grade (R-UVG) Channel Unit provides six, 2-wire switched analog circuits. The R-UVG is the L-UVG's counterpart and is equipped at the Remote Subscriber Terminal. The R-UVG card is direct-mapped to the corresponding L-UVG card and establishes six dedicated circuits, thereby reducing the total number of spans that can be concentrated. Ground key and loop start are supported. R-UVG cards provide ring cadence following, on-hook transmission, and forward disconnect. The R-UVG also supports precision gain adjustment in 0.1 dB steps over a 12.0 dB range.

NOTE : We have special versions of R-UVG : SLC-T(Subscriber Line Circuit for Terminal) and DPO(Dail Pulse Originating). They are designed for Korea applications. Therefore they can support Korea R2 and Korea D4 signal. The hardware of SLC-T and DPO are the same as R-UVG. Please refer to 4.4.8 R-UVG spec. for the detail electrical features of SLC-T and DPO.

2.6 Digital Channel Units

HTC-1100E can also be provisioned with a full range of digital services. Any service card can be placed in any general-purpose slot up to the limit of CBA's slot capacity. Table 2-2 summarizes the channel units available for the HTC-1100E system.

Table 2-2: Service Units

LET	RST	Circuits Per Card	Service Descriptions
LI-ISDN	RI-ISDN	2 digital data	Provide two ISDN basic rate (2B+D) U-Interface
ADU	ADU	2 digital data	Asynchronous digital data. Software provisionable for 0.3,0.6,1.2,2.4,4.8,9.6, 19.2 or 38.4 Kbps applications.
E&M	E&M	1 or 2 two- or four-wire (mode dependent)	Analog E&M connections used in a Central Office. Can be provisioned for two- or four-wire applications. Supports all modes including PLR, Tandem, and DX.
E1AX	E1AX	1 E1 ckt.	Asynchronous, non-line powering, non-channelized (intact), digital circuit for 2.048Mbps E1 data applications. Used when providing E1 at a G.703 signaling level. Does not provide sealing current.
DD1.5	DD1.5	1 DS1 ckt.	Line powering, digital circuit for 1.544 Mbps data applications. Used when providing DS1 directly to customer for data or PBX.
LI-POTS LI-APOTS LI-EPOTS	RI-POTS RI-APOTS RI-EPOTS	6 POTS	Analog, two-wire, "Plain Old Telephone Service" applications.
SDU	SDU	1 digital data	Synchronous digital data. Software provisionable for, 0.6,1.2,2.4,4.8,9.6,19.2, 38.4,48,56 or 64 Kbps applications.
CO64	CO64	3 digital data	The transmission and receiver format provides three 64 kbps channels, respectively.
N64P	N64P	1 digital data	Synchronous digital data. Software provisionable for N×64kbps (N = 1.. 30) applications. Connect with multiplexer and subscriber DTE by V.35/V.36 interface

LAN	LAN	1 digital data	Synchronous digital data. Software provisionable for N×64kbps (N = 1.. 30) applications. Connect with multiplexer and subscriber DTE by LAN interface (10/100 Base T)
DD64 CO64 SDU	DD64	1 digital data	Multi-rate, full duplex, synchronous data interface 4 Wire interface, up to 64kbps data rate
L-UVG SLC-E DPT	R-UVG SLC-T DPO	6 POTS, 2-wire switched analog circuits	Support ground start, loop start, on-hook transmission, pulse metering, and battery reversal signaling for applications such as PBX trunks. It may be employed for Direct-Inward-Dial (DID) applications.
IDSL	IDSL	2 digital data	Provide two ISDN basic rate (2B) U-Interface

The Channel units, described below, provide digital interfaces for private or public network use. Flexible bandwidth management allows HTC-1100E to offer services without degradation of adjacent services.

2.6.1 LET International ISDN Channel Unit (LI-ISDN)

The HTC-1100E Local Exchange Terminal ISDN channel unit (LI-ISDN) provides two ISDN ‘U’ circuits. The LI-ISDN is designed to transport the 2B+D data from the Local exchange as three 64Kbps timeslots through the HTC-1100E to the remote terminal where the RI-ISDN recreates the physical 2B+D format for relay to the customer. The LI-ISDN channel units utilize mixed analog and digital signal processing circuit technology as described in TR-397. The LI-ISDN uses 2B1Q (2 binary 1 quarternary) line coding for full-duplex transmission at 160 Kbps data rate. The transmission format provides two 64 Kbps (B-channels), one 16Kbps channel (D-channel) and one 4 Kbps control channel. The LI-ISDN channel unit provides a DC termination to sealing current as well as loop test verification. The LI-ISDN will support 3-channel TDM multiplex format.

2.6.2 RST International ISDN Channel Unit (RI-ISDN)

The HTC-1100E Remote Subscriber Terminal ISDN channel unit (RI-ISDN) provides two ISDN ‘U’ circuits. The RI-ISDN recreates the physical 2B+D format for relay to the customer from the LI-ISDN unit. The RI-ISDN channel units utilize mixed analog and digital signal processing circuit technology as described in TR-397. The RI-ISDN uses 2B1Q(2 binary 1quarternary) line coding for full-duplex transmission at 160 Kbps data rate. The transmission format provides two 64 Kbps channels (B-channels), one 16 Kbps channel (D-channel), and one 4 Kbps control channel. The RI-ISDN will support 3-channel TDM multiplexing format. The RI-ISDN Channel Unit has an approximate working range of 5.49 km (18 Kft) over 0.5mm (#24 AWG) cable.

2.6.3 ADU Channel Unit

The Asynchronous Data Channel Unit (ADU) provides up to two full duplex, asynchronous data interfaces (V.24/V.28). It operates at multiple data rates including 300, 600, 1200, 2400, 4800, 9600 and 19,200 and 38,400

bits per second. The ADU also supports sub-rate multiplexing.

2.6.4 SDU Channel Unit

The Synchronous Data Channel Unit (SDU) provides a full duplex, synchronous data interface (V.24/V.35/V.11). It operates at multiple data rates including 0.6, 1.2, 2.4, 4.8, 9.6, 19.2, 38.4, 48, 56, and 64 Kbps.

2.6.5 N64P Channel Unit

The HTC-1100E N64P channel unit provides 1 circuit N×64kbps (N = 1...30) per card. This multiple rate can be setting by HTC-1100E craft interface. The N64P card plugs in LET and RST of the HTC-1100E. In the LET N64P card and RST N64P card connect with Local Exchange and subscriber DTE equipment by V.35/V.36 interface , respective.

2.6.6 E1AX Channel Unit

The E1 Asynchronous Channel Unit (E1AX) provides a G.703 level asynchronous (intact) E1 rate interface, transmitting and receiving at 2.048 Mbps. This unit provides intact transmission of E1 signals, and supports the economical delivery of E1 services directly to subscriber locations. The transceiver is designed to interface with other multiplex equipment that utilizes a G.703 signaling level. For synchronous, channelized E1 rate interfaces, the non-line powering E1 transceiver (E1X) may be used as a digital service card in place of the E1AX card.

2.6.7 E1X Channel Unit

The E1 Synchronous Channel Unit (E1X) provides a G.703 level Synchronous (intact) E1 rate interface, transmitting and receiving at 2.048 Mbps. This unit provides intact transmission of E1 signals, and supports the economical delivery of E1 services directly to subscriber locations. The transceiver is designed to interface with other multiplex equipment that utilizes a G.703 signaling level.

2.6.8 DS1 Channel Unit (DD1.5)

The HTC-1100E DS1 Transceiver (DD1.5) provides a DSX-1 level DS1 rate interface, transmitting and receiving 1.544 Mbps. This unit provides transmission of DS1 signals, and supports the economical delivery of DS1 services directly to subscriber locations. The transceiver is designed to interface with other multiplex equipment that does not require a powered interface. In such applications, the DD1.5 may drive a DSX level signal 200 meters. The signal is transmitted transparently as a data stream and is passed to its destination.

2.6.9 CO64 Channel Unit

The HTC-1100 co-directional 64kbps (CO64) channel unit provides 3 circuits per card. The transmission and receiver format provides three 64 kbps channels, respectively. CO64 card plug in LET and RST of the HTC-1100. In the LET CO64 card use 4 wire connect with local exchange and RST CO64 card connect with subscriber DCT equipment.

2.6.10 Digital Data 64Kbps(DD64)

The Digital Data 64Kbps Channel Unit (DD64) provides a multi-rate, full duplex, synchronous data interface, transmitting and receiving data over outdoor cable plant wiring. The DD64 may be used at LET or RST of the

HTC-1100. It operates at 2.4, 4.8, 9.6, 19.2, 56 and 64Kbps data rates. Receive cable equalization is adaptive depending on cable length. The DD64 can perform zero suppression, BCH error correction and majority vote error correction. In addition several customer-controlled loopbacks are supported. The DD64 card also has DDS Secondary Channel capability.

2.6.11 ISDN Digital Subscriber Line Channel Unit (IDSL)

The HTC-1100E ISDN Digital Subscriber Line channel unit (IDSL) provides two ISDN 'U' circuits. IDSL may be used at LET or RST of the HTC-1100. The IDSL recreates the physical 2B+D format for relay to the customer. The IDSL channel units utilize mixed analog and digital signal processing circuit technology as described in TR-397. The IDSL uses 2B1Q(2 binary 1quarternary) line coding for full-duplex transmission at 160 Kbps data rate. The transmission format provides two 64 Kbps channels (B-channels). The IDSL will support 2-channel TDM multiplexing format. IDSL doesn't provide power feeding. The IDSL Channel Unit has an approximate working range of 5.49 km (18 Kft) over 0.5mm (#24 AWG) cable.

2.6.12 Clock Card (CLK Card)

The Clock Card seated on COT site is designed for recovering the external timing source to offer the whole system a precise and reliable reference clock for data transmission. There is a slip being taking place when transmit and receive clock not synchronized with each other. The Clock Card extracts the clock from external timing source, whose format includes E1, 2048kHz Square-Wave and 64kbps Composite Clock.

The synchronization clock is seated on COT site. The output clock of this Clock Card could be carried to the subordinate COT DLC far from via optical transmission media. The output format includes E1, 2048kHz Square-Wave and 64kbps Composite Clock.

2.7 Craft Interface Features

The HTC-1100E Craft Interface can be accessed via any ASCII terminal from either an LET or RST. The Craft Interface features a simple menu-driven interface. User identification and password are required to access the system.

Once entering a correct user identification and password, a user logs into the top-level menu and can access any sub-menus to execute features as desired.

2.7.1 Provisioning Menu Features

Though the system is shipped with a complete set of pre-defined system values, and in many cases may be installed without modifying these values, the provisioning features allow craft persons to change these settings for unique system environments and applications.

The System Configuration features are used to define the system topology. This includes specifying the number of terminals present, the switch interface type, and the circuits, which have timeslots permanently assigned. The System Configuration features also allow display of default system topology and its modifications. It allows craft persons to select the base system topology, to modify the system topology, and to set direct digital switch interface options.

The Installation and Turn-up features are used to specify and retrieve terminal configuration information such as channel units in service and timing source selection. With these features the system can display, on a slot by slot basis, what type of circuit pack is currently equipped. These features also provide the circuit packs' serial numbers, version and revision numbers. It can also display each terminal's timing source selections.

The system builds cross-connects for all circuits on the cards occupying the two slots specified in the Plug-In Cross-Connects commands. HTC-1100E also supports "Groomed" function. The groomed function allows the user to maximize E1 span use by assigning various non-switched services to a common E1 span.

The transceiver Settings Features allow crafts people to set transceiver options such as frame format and zero suppression technique. Additional features allow the alarm thresholds to be modified and retrieved.

The Circuit Setting Features are used to operate on the subscriber circuit options settings. For analog services, this includes such settings as transmission and receiving gain, termination impedance, and equalization settings. For digital services this includes, the data rate and error correction scheme. The features in the Circuit Settings Menu set and retrieve the operating parameters for the analog and digital subscriber interface channel units. As the channel units contain few strapping options, most of the operational parameters are adjustable through the Craft Interface. With the Circuit Settings Features the user can display or modify settings for each circuit in the system. Circuit parameters that may be set vary, depending on the channel unit used.

2.7.2 Maintenance Menu Features

The Maintenance Menu Features allow craft persons to quickly gain an understanding of HTC-1100E □ current operating status. The user can display events and alarms, their severity, and the time they became active. These alarms include plug-in status alarms (such as broken or missing plug-ins), terminal interface alarms (such as switch interface datalink failure), facility alarms (such as a facility loss of frame alarm), and subscriber interface circuit alarms (such as illegal signaling patterns). This alarm report augments the LED displays to provide enhanced failure diagnostics. The user can also release the office alarm closures for currently active alarms. This duplicates the functionality of the alarm cut-off button. Additionally, the user can display the most recent alarms that were active in order to gain the alarm trends during fault diagnosis. Finally, the user can

display the current and previous fifteen-minute, hourly and daily performance monitoring data for the transceivers, digital subscriber interfaces, and system indexes. Continuous hourly performance data (e.g. Error Second (ES), Severe Error Second (SES) and Unavailable Second (UAS) etc.) of the past seven days are maintained. If required, the performance-monitored data could be zeroed by operator issuing for recalculating data.

2.7.3 Testing Menu Features

The Features in the Testing Menu allow craft persons to trouble shoot the system. With this menu the user can perform system diagnostics. There are four levels of diagnostic tests. The first level reports the current background diagnostic results. These diagnostics are run continuously and autonomously by HTC-1100E. They are fully non-intrusive on service. The second level of diagnostics are non-intrusive active tests. In this case the system tests all circuits that are currently not in use. This set of tests requires the Metallic Test Unit (MTU) for correct operation. The third level of diagnostics does a full set of circuit tests. This set of tests, which also requires an MTU, interrupts service during the test sequence. The fourth level of diagnostics is also a service affecting diagnostic, in which the full power-up diagnostic test is run. In all cases, the results of the diagnostic process are reported to the crafts persons via Craft Interface.

The user can cycle through all of the LEDs in the system for a visual verification of their operation and list the currently active loopbacks. Loopbacks are available for the subscriber and transceiver interfaces at both the channel and facility levels. In some cases, both analog and digital loopbacks are available, allowing for progressive loopbacks to be employed to help locate faulty circuits.

2.7.4 Administration Menu Features

The Administration Menu Features handle the time and date settings and Craft Interface security. Functions include setting and displaying the time and date, and the creation of passwords for up to ten users.

2.8 Element Management System

The Element Management System is a valued addition to the HTC-1100E product, which already provides a local craft interface terminal (CIT). The EMS now provides a Graphic User Interface for complete control and supervise of HTC Digital Loop Carrier (DLC) networks. EMS allows multiple operators to monitor alarms, control nodes and generate report. The EMS follows the concepts of TMN (Telecommunications Management Network) as described in ITU-T M.3000 series, which greatly enhance service provider's ability to manage their network. Furthermore, while inserting ATU cards in both LET and RST, EMS Query System can execute efficient management and testing functionalities.

HTC 1100E's Element Management System offers functions for management and maintenance personal such as: auto-detect and manual detect, auto alarm, and database searching, etc. This unique software design is intended for easy system operation, which can control the network, and verify testing of local and remote connections. When errors are found, it can send an immediate report to your alarm system. It's the best and most powerful tools for system maintenance.

2.8.1 Windows Operating system

This management system requires a personal PC server under Windows NT/Windows 95. It is based on Visual Basic 5.0 to develop a very easy to use, easy learning, wise centralized management system and to offer a superior user-friendly interface. All functions are based on traditional Windows format to increase operating efficiency.

2.8.2 24-hour system status detection and reporting

The EMS can automatically detect system status and report any system faulty in time that facilitates system maintenance operators have a clear control of network conditions in anytime. Moreover, the system information desktop will display the complete status condition so that it is easy to control every sequence and every network connection condition.

2.8.3 Manual Mode

When an alarm report is recorded, the user member can manually select the alarm point within the Alarm Information window and directly open the connection. The system will automatically enter the alarm point in manual mode. Or you can manually enter the alarm system information window to detect the error condition, and immediately go to the core of the problem from the alarm point.

2.8.4 Remote Loop test of MTU

When the telephone user informs the operator the connection error, the operator only needs to input the users telephone number to execute the MTU test. Through the test result, the operator can view and analyze the reason of connection problem via EMS.

2.8.5 E1 Transceiver (E1X-XCVR)

The HTC-1100E E1 Transceiver provides an indoor E1 (G.703) level interface, transmitting and receiving up to 30 Basic 64 Kbps channels of voice or data originating from either the channel unit or another E1 transceiver. The E1-XCVR may be used at either the channel units or another E1 transceiver. It operates at the E1 rate of 2.048 Mbps. The E1X-XCVR is intended for use in applications requiring interface to multiplexers or other co-located office equipment. Its faceplate is shown on this page.

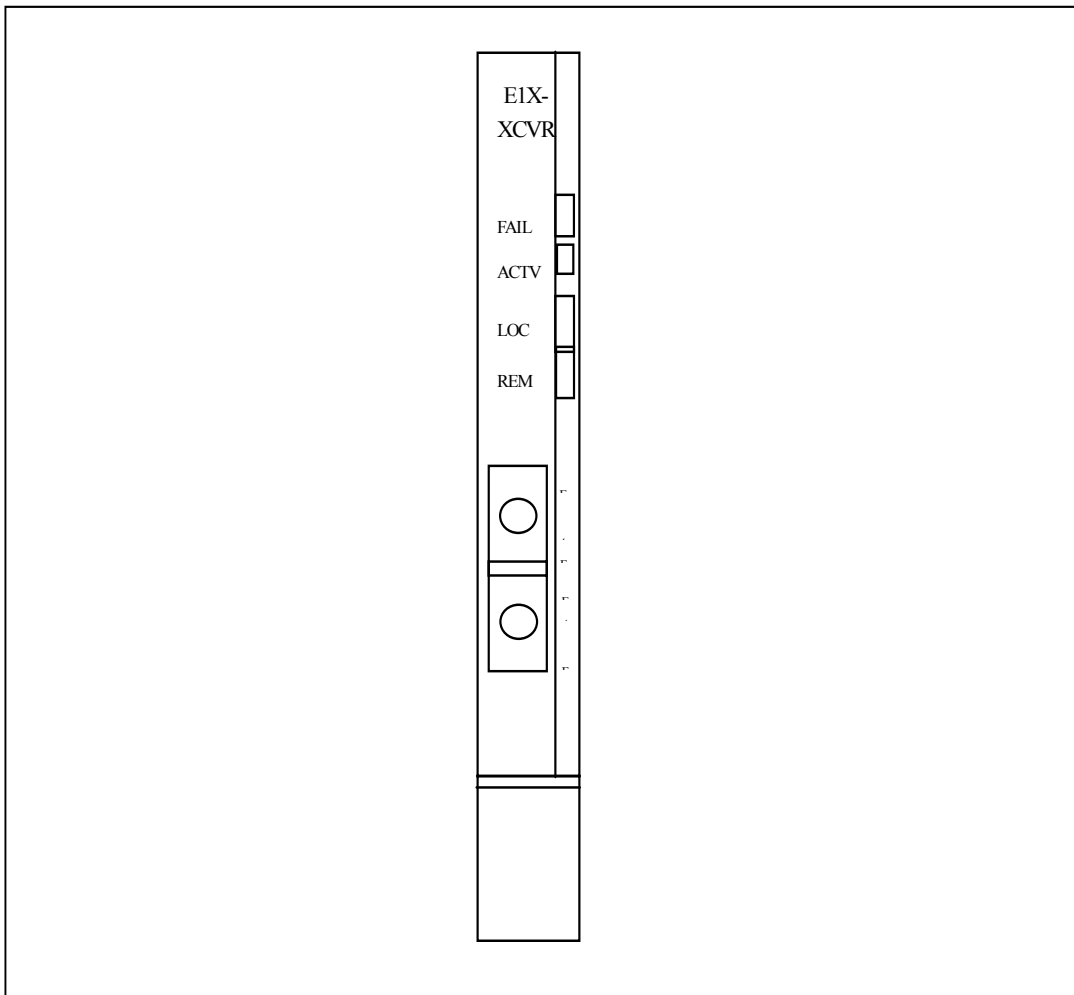

The E1X-XCVR Transceiver performs signaling conversion and data link termination. Line coding is HDB3. The transceiver has selectable alarm thresholds, BER calculation, performance monitoring statistics, and alarm history.

The E1X-XCVR may also be used as a service card, to drop off a single channelized E1 circuit to a customer's G.703 equipment.

There are four LED indicators on the E1X-XCVR Transceiver front panel. A green ACTV LED indicates the unit is busy and must not be unplugged without first removing traffic. A red FAIL LED indicates that the unit has failed. An amber REM LED indicates that the unit is in Far End Alarm, and another amber LOC LED indicates that the unit is in Near END alarm. The transceiver features front panel jack access for testing and monitoring.

Features

- One ITU-T/E1 2.048 Mbps Interface per card
- Double frame, CRC multi-frame formats
- Extensive Loopback Diagnostics
- Front Panel Jack Access for Test and monitoring
- Remote Test Access to Metallic Tip and Ring (In the future)
- Low Power Dissipation
- May be used to deliver fractional E1 to customers or for groomed services

E1X-XCVR Specification	
<u>Signaling Features</u>	
Line Rate	2.048 Mbps ± 50 ppm
Framing	Double frame, CRC multi-frame
Line Coding	HDB3
Channel sequence	CAS or CCS
Error Checking	CRC4
Loopback Modes	Local, Remote
<u>Analog Parameters</u>	
Equalization	Receive Automatic Line Build Out (10 dB attenuation)
	Transmit Fixed 3.0 Vpk±0.3 Vpk
Input Impedance	120Ω(twisted pair)
<u>Environmental</u>	
Operating temperature	-35°C to +60°C
Humidity	up to 98% at 35°C
Max Power Consumption	2.5 W
<u>Dimensions</u>	
	5.125" (13.018 cm) tall (standing up in CBA)
	10.5" (26.67 cm) long (from front of CBA to CBA backplane)
	0.563" (1.429 cm) thick (measured along faceplate - thickest point)
<u>Weight</u>	
	0.5 lbs (0.23 Kilograms)
<u>Compliance</u>	
Jitter	ITU-T G.703 / G.823
Cable Interface	ITU-T G.703
Return Loss	ITU-T G.703
Frame/CRC-4 Multiframe	ITU-T G.704 / G.706
LOF and recovery	ITU-T G.706
LOS	ETSI 300 461-1

2.8.6 Three-stage Loop test of ATU

The operator can execute ATU test to checked user’s telephone line transmission path status from Exchange to LET or from LET to RST and outdoor cable from RST when the system transmission loops have problem occurred. Through the test results, the operators can view and analyze the reasons of connection problem via EMS.

2.8.7 Complete Database Checking Function

All local and remote connections and user side data that is created by this system will be saved into the database. Moreover, the Alarm History and Traffic Statistics will also be saved into the database. This system can offer a complete analysis function for every data record. Any information can, depending on actual needs, be organized and printed in daily, weekly, or monthly report format. Local and remote connections and the user side records alarm information will be shown on this report.

2.8.8 Detailed Alarm Support and Easy System Configuration

This system not only offers a superior user-friendly interface, it also supports an external alarm so that the whole system will be protected. When there is a power shortage, the system will change to the internal battery (with up to 8 hours of power supply) to maintain power to the system. At this moment the alarm condition will be shown in the Power Failure window, recording the system ID and power surge/failure time, and every half hour, the battery life will be displayed, so that the operator knows how much time remains before system shutdown. Moreover, when any outer power failure or other reason forces the unit door to open, an alarm message will be displayed in the Alarm Information window indicating that the safety of the system needs to be secured.

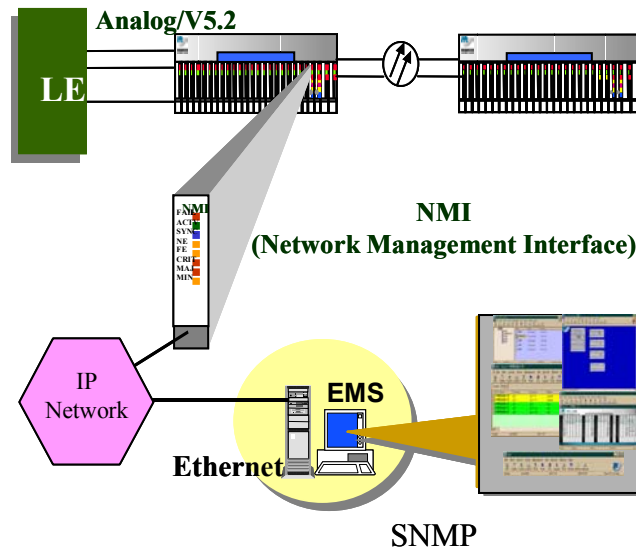

Figure 2.3 EMS network connection diagram

3 General Specifications

This section lists the technical specifications for the HTC-1100E and for each of its components, including channel bank assemblies, remote subscriber cabinets, control cards, transmission cards, and subscriber cards.

3.1 Transmission Media Specifications

<u>Line rate</u>	E1	2.048 Mbps	±50 ppm
	Fiber	49.152 Mbps	±50 ppm
<u>Line Code</u>	E1		HDB3
	Fiber	Scrambled	NRZI
<u>Pulse Amplitude</u>	E1	3.0 Vpk	ITU-T G.703 Sec 6.
	Fiber	-7 dBm (laser)	@ 1,310/1550 nm
<u>Maximum Span Attenuation</u>	E1	-38 dB	@ 1,024 Khz
	Fiber	-34 dB	@ 49.152 Mbps
<u>Frame Format</u>	E1	32 Timeslots/Frame Timeslot 0 Timeslot 16	ITU-T G.704 Framing Signaling
	Fiber	Line Coding Line Rate 8 bit/Timeslot	NRZI, Scrambled 49.152 Mbps ITU-T G.711
<u>Companding</u>	A Law		
<u>Impedance</u>	E1	120 Ω	± 5 % (Balanced)
<u>Repeater Spacing</u>	E1	Maximum 38 dB	
<u>Repeater Powering</u>	E1	-130 volt Simplex HDSL	60 mA -180 volt

3.2 Signaling Specifications

<u>DC Supervisor</u>		
Exchange	Off Hook	500 Ω
On Hook	10 kΩ	
Remote DC supervisory range		1800Ω@25 mA
	(Including telephone)	
	Idle circuit voltage	≥ -56 volts
	(Battery feed)	≤ -42 volts
	Loop Current	
		Constant current 25 mA
<u>Battery Reversal</u>	LET-RST	< 50 mSec
	Quiet Reversal Option	< 80 mSec
<u>Forward Disconnect</u>	LET-RST	< 50 mSec
<u>Single Pulse Distortion</u>	LET-RST	< 12 mSec
<u>Pulse Metering</u>	Software provisionable	12KHz or 16KHz

3.3 Voice Interface Specifications

<u>Impedance</u>	600Ω or 900Ω	
<u>Insertion Loss</u>		
Remote	2 dB	± 0.5 dB
<u>Return Loss</u>	ITU-T G.122	
	2 Wire	
		RL > 15 dB (300 ~ 600 Hz)
		RL > 18 dB (600 ~ 3000 Hz)
	4 Wire	
		RL > 15 dB (3000 ~ 3400 Hz)
		RL > 20 dB (300 ~ 3400 Hz)
<u>Frequency Response</u>	ITU-T G.713	
<u>Idle Channel Noise</u>		
	≤ -65 dBm0	G.712
<u>Crosstalk</u>	line to line	< -67 dBm0
<u>Longitudinal Balance</u>	ITU-T G.177 & G.121	
<u>Amplitude Tracking</u>	ITU-T G.713 & G.714	
<u>Single Frequency Distortion</u>	ITU-T G.713 & G.714	
<u>Intermodulation Distortion</u>	ITU-T G.713 & G.714	
<u>Signal-to-Distortion Ratio</u>	ITU-T G.713 & G.716	
<u>Group Delay Distortion</u>	ITU-T G.713	
<u>Spurious In-band Signals</u>	< -40 dBm0 (300 ~ 3400 Hz) @ Except the frequency range of input signal	
<u>Spurious Out-band Signals</u>	< -25 dBm0 (4.6 ~ 128 KHz) @ the input signal frequency from 200 ~ 3400 Hz)	
<u>Impulse noise</u>	< -47 dBmC0 (under 15 times per 15 minutes)	
<u>V.34 Modem transition</u>	BER ≤ 10 ⁻⁷ @ Rate: ≥ 31.2 kbits	

3.4 Ringing Specifications

<u>Ringling Detection</u>		
	Voltage Range	20 ~ 100Vrms
	Frequency Range	14 Hz - 55 Hz
	Minimum Detection Duration	150 mSec
<u>Ringling Generation</u>		
	(Software programmable)	20Hz to 30 Hz (per shelf)
<u>Ringling Voltage</u>		
	(Software programmable)	60, 65, 85 or 95 Vrms (Sine)
<u>Ringling Delay</u>		
	End-to-end	< 200 mSec
<u>Ring Envelope Distortion</u>		
	End-to-end	< 25 mSec
<u>Ring Amplitude Distortion</u>		
	End-to-end	< 10 %
<u>Ring Cadence</u>		
	RST	Ring Following
<u>Maximum Ringing</u>		
	RST	5 REN per line.

3.5 Dialing Specifications

<u>Dial Pulsing</u>	7 to 13 pps	
	BRK in	50 - 70%
	BRK out	45 - 75%
<u>Signaling Delay</u>	< 50 mSec	
<u>Pulse Distortion</u>	< 15 mSec (Open Interval 50 mSec - 2 Sec)	
<u>On Hook Transmission</u>	Between Ring bursts, 5 seconds after call completion	

3.6 General Specifications

System Synchronization

- 1. external 2.048 MHz ±50 ppm Square Wave
- 2. external 2.048 Mbps ±50 ppm E1 (G.703) Option
- 3. external 64.0 kbps ±50 ppm composite Clock Option
- 4. CPU internal 16.384 MHz ±20 ppm

Alarms

Critical/Major/Minor with Alarm Cut Off (ACO)
 Alarm thresholds software programmable

Powering

LET	-42 ~ -63Vdc	@4Amps max
RST Local AC	110 ~ 220Vac	Charger
	50 ~ 60Hz	1.0 Amp
RST Exchange DC	E1	-130 volt

Compliance

CISPR22 Class A
 IEC 1000-4-2 Class 1

3.7 Environmental Specifications

(Including of Network Management Workstation and Craft Interface Terminal)

<u>Inside (Rack Mounted)</u>	-10°C to 50°C inside ambient temperature
<u>Controlled Environment</u>	-10°C to 50°C inside ambient temperature up to 95% at 35°C
<u>Outdoor Environment</u>	-35°C to 60°C outside ambient temperature
<u>Remote Cabinet Environment</u>	-35°C to 60°C outside ambient temperature up to 98% relative humidity (non-condensing) at 35°C

3.8 Mechanical Specifications

<u>Channel Bank Assembly</u>		Height	7" (17.8 cm)
(mild steel, galvanized)		Width	19" (48.2 cm)
Depth			12" (30.5 cm)
<u>Fuse & Alarm Assembly</u>		Height	2" (5.1 cm)
(mild steel, galvanized)		Width	19" (48.3 cm)
Depth			11" (27.9 cm)
<u>Remote Subscriber Cabinets (RSC/240-360)</u>			
Height		55.5" (140.9 cm)	
Width		42" (106.7 cm)	
Depth		31" (78.7 cm)	
Weight		475 lbs. (216 Kilograms)	

3.9 HTC-1100E Reliability Calculations

<u>CARD MTBF (in hours)</u>		
<u>Card</u>	<u>MTBF (HOURS)</u>	<u>FITS</u>
CPU	216,000	4636
L-PSU	449,000	2227
R-PSU	293,000	3413
LI-POTS	324,000	3084
RI-POTS	320,000	3125
LI-EPOTS	336,000	3164
RI-EPOTS	341,000	3255
LI-ISDN	530,000	1783
RI-ISDN	552,000	1825
E&M(2W/4W)	354,000	3029
IDSL(64K&128K,DSL)	520,000	1625
E1X-XCVR	594,000	1685
FOX-XCVR	485,000	2062
ELU	560,000	1786
EBC	451,000	2217
SDH-XCVR	475,000	1894
 <u>SYSTEM LEVEL (in years)</u>		
<u>Examples (Redundant Configuration)</u>	<u>MTBF</u>	<u>FITS</u>
One POTS line through LET and RST	62.7	1820
Total System	194	588

4 Unit Description and Specification

The Central Processing Unit (CPU) is responsible for the overall control of the HTC-1100E and is used at both the LET and RST nodes. It performs system initialization, provisioning, alarm reporting, maintenance, diagnostics, and fault detection. In addition, it performs timing sources selection, synchronization to external timing sources, provides a high stability internal timing reference.

4.1 Apparatus

4.1.1 Channel Bank Assembly (CBA)

HTC-1100E's system architecture is comprised of two basic network elements. These include the Local Exchange Terminal (LET), located the central office, and one or more Remote Subscriber Terminals (RST), located at the end of various transport media.

The LET and RST are composed of identical, twenty-six slot Channel Bank Assemblies (CBA). Each CBA consists of two Central Processing Unit slots, two Power Supply Unit slots, and twenty-two general purpose card slots on a 98 Mbps backplane. The CBA has incorporated several unique design features which make it especially flexible and cost effective. One shelf provides both common control and distribution of services. There is no need for a separate common control shelf, allowing HTC-1100E to have extremely low Start-up costs. Any service card may be plugged into any general purpose card slot. All cards designed for HTC-1100E are the same physical size, from the six DS0 (64 Kbps) POTS card to the 50 Mbps Fiber Optic Transceiver.

Expansion of HTC-1100E is accomplished quickly and easily by adding one or more CBA's linked to the primary shelf by fiber optic cable. Each HTC-1100E system may be configured for up to 672, 64 Kbps channels, or maximum of eight CBA's.

The Channel Bank Assembly (CBA) is the principal component of any HTC-1100E configuration. It consists of a pre-formed cold rolled steel, powder coated card cage, metal rear covers, printed circuit board back panel, and mounting hardware. The CBA contains all the hardware necessary for installation, excluding cabling for voice, data and power. The customer may chose to wire-wrap directly to HTC-1100E back panel or use a custom wiring harness which is pre-wrapped to the back panel with connectors.

The CBA also includes the Air Ramp. In addition to facilitating the convection cooling of the system, the Air Ramp provides fiber routing functions. It also provides the RS232-C Craft Interface, the Order Wire connection, and the Electro-static Discharge (ESD) jack. The same CBA is used in both the LET and RST. It can be configured either as a Primary or an Expansion CBA.

The card cage consists of a pre-formed metal shelf, 7" tall by 19" wide by 12" deep, and has 26 equipment slot guides. The card cage is designed to be flush mounted in a 19" equipment rack, but it can be adapted for projection mounting or 23" rack mounting, or both. The card cage attaches to the rear cover to prevent accidental electrical shorts or mechanical damage to the backplane. HITRON could provide at least eight(8) shelves, ie 960 subscriber lines to be placed in one 9 feet rack which located in central office.

The backplane is mode of FR4 glass-fiber, 4 layers, 3-mm thick. The backplane has 1-mm square wire-wrap posts for VF and transceiver data termination, screw-down power and ground terminals.

Features

- Highly compact and durable
- Alarm Contact closure wire-wrap posts
- System timing inputs using wire-wrap posts
- Order Wire Connection
- Craft Interface (RS-232) Connection
- Integrated Fiber Splice Tray
- Optional 19" or 23" rack mounting

- Optional 5" projection mounting

4.1.2 Fuse & Alarm Assembly (FAA)

The Fuse and Alarm Assembly (FAA) consists of a Pre-formed mild-steel enclosure, wire wrap termination field, fuse block and mounting hardware. The FAA is used at the LET for connection of multiple LET HTC-1100E terminals to the exchange power plant. The FAA allows connection of exchange battery (nominal -48 volts). The fuses are rated at 5 Amps and have a contact closure alarm, which is wired across the fuse block to generate an exchange alarm (normally open). In addition, the FAA also supports a wire wrap field where multiple HTC-1100E alarm points may be wired from the systems in the rack. These include Major, minor audible and visual alarms as well as discrete contact closure, which are software definable. System alarms are also indicated with LED's.

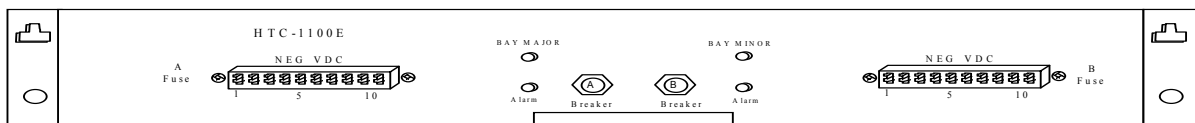

Fuse & Alarm Assembly, Front View

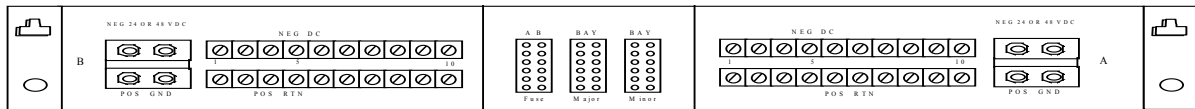

Fuse & Alarm Assembly, Rear View

The enclosure consists of a pre-formed steel, power coated mounting bracket, 2" tall by 19" wide by 11" deep, and holds the power distribution fuses and wire-wrap field. The enclosure is designed to allow the FAA to be flush mounted with the equipment rack, but it can also be adapted for front mounting, or mounting in a 23" rack, or both. The FAA rear cover is used to prevent accidental electrical shorts on the exchange battery.

Features

- LED System Alarm display
- Order Wire Interface
- Alarm Contact closure wire-wrap posts

FAA Specifications

FAA Enclosure

Mild Steel, powder coated. Rear cover of clear plastic construction.

ALARM I/O

Normally open contacts for Major alarm, Minor alarm, wired from HTC-1100E. Audible contacts, remote alarm cut-off and general-purpose user definable inputs may be routed up to FAA.

FUSES

10 X 2 fuses, Bussman alarm
activating with visual indication 5 Amp, 250V

Alarm Displays (Major and Minor)

Solid State LED modules with integral resistors.

Mounting Configurations

19" rack/flush mount - standard
23" rack extended brackets - optional
Front mounting (5" projection) brackets - optional

Dimensions

2" tall by 19" wide by 11" deep

Weight

14 lbs (6.36 Kilograms)

4.1.3 RSC/240-360

The HTC-1100E Remote Subscriber Cabinet (RSC/240-360) is an environmentally controlled enclosure supporting one or two Channel Bank Assemblies (CBA). The cabinet seats on the concrete pad. The RSC/240-360 has a total capacity of 240-360 lines.

The cabinet and corresponding base should be kept from erosion, dust and water-resistant. RSC/240-360 has placed a ring device on the top for moving convenient.

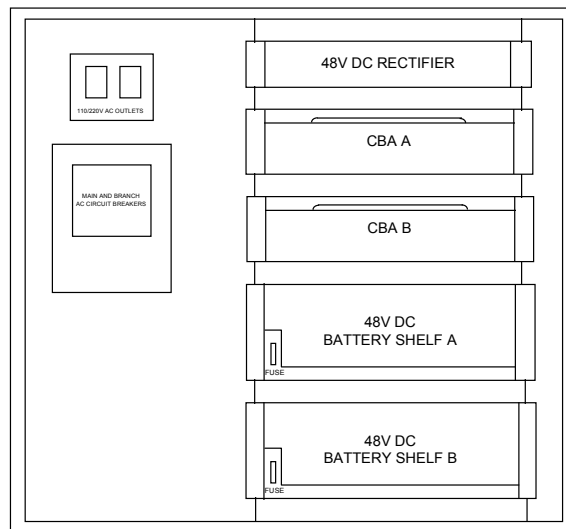

RSC/240-360 Front View

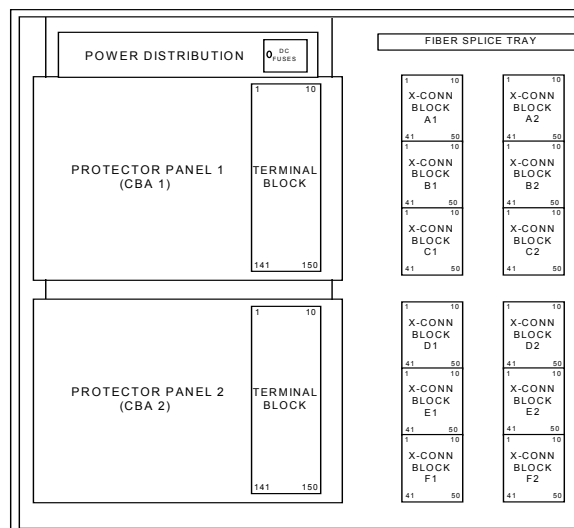

RSC/240-360 Rear View

The RSC/240-360 enclosure is constructed of 1/8" powder coated aluminum. The cabinet is cooled by utilizing a double wall heat exchanger in addition to DC powered fans. The heat exchanger allows air to circulate between the inner and outer walls allowing HTC-1100E equipment compartment to maintain a favorable temperature range, even during the most inclement weather. The DC powered fan is immune to AC power failures. The combination of

HTC-1100E System Description

these design features provides HTC-1100E equipment with a technologically advanced sealed enclosure, and prevents contaminants from entering the equipment area.

The RSC/240-360 may be equipped with 48V battery strings, which provide 8-12 hours backup capacity. The battery tray is located in the bottom of the cabinet. Battery heater is available for use in regions with colder climates.

The cabinet has front and rear access doors. The front door allows access to the equipment side of the cabinet. The equipment side of the RSC/240-360 may contain some or all of the following:

Channel Bank Assemblies (Front)

Main & Branch Circuit Breakers

48 V DC Power Supply

Battery String(s)

Twelve (12) Position Fiber Distribution Panel(s)(Fusion or Mechanical)

The front door is equipped with a key lock and pad lock tab. The rear door allows access to the splice side of the cabinet. The splice side of the RSC/240-360 may contain some or all of the following:

- Channel Bank Assembly (Rear)
- Main Ground Bus Bar
- Fiber Splicing Area and Tray(s)
- Cable Splicing Area
- E1/E1 Wire Wrap Field
- MS² Connectors
- AC Power Protection With Outlet

The rear, like the front, is equipped with a key lock and pad lock tab.

As an option, the RSC/240-360 may be equipped with a fully integrated cross connect which utilizes tool-less, punch down blocks. The RSC/240-360 may be locally powered via 110 or 220 Vac.

The RSC/240-360 is designed for pedestal mounting on a pre-cast concrete pad.

Features

- Environmental Alarms
- Cabinet Designed To NEMA 4 Standards -- Prevents Contaminants From Entering Equipment Area
- DC Power Fans
- 240-360 Lines Of Capacity
- The wire to subscriber would be voltage protected by Gas-Tube
- Shake resistant and compliance with FCC 68.302 and ETSI 300 019

RSC/240-360 Specifications

Enclosure Aluminum, powder coated, painted natural tan. Cabinet cable entry through base plate in cable splice management area.

- Powering**
- Sealed Lead Acid Batteries Available for 8 to 12 Hours Backup.
 - 48 Volt Battery Charger With 220/110 Volt, 50/60 Hz. Connection.
 - Thermal Battery Heaters Available For Colder Climates.
 - Local AC 220/110 Volt Service Entry and External Motor Generator Input.
 - DC Powered Fan.
 - Ground Resistance $\leq 20\Omega$
 - Ground Busbar, Battery Ground and System Ground.

Environmental

Operating Temperature: -35°C to +60°C
Outside Ambient Temperature with full sunlight

Humidity: 0 - 98% non-condensing at 35°C

Mounting Pad Mounted

Dimensions 55.5"(140.9 cm) tall by 42"(106.7 cm) wide by 31"(78.7 cm) deep
(Same measurements with or without cross connect)

Weight 475 lbs. (216 Kilograms)

4.1.4 RSC/480-600

The HTC-1100E Remote Subscriber Cabinet (RSC/480-600) is an environmentally controlled enclosure supporting one or two Channel Bank Assemblies (CBA). The cabinet seats on the concrete pad. The RSC480-600 has a total capacity of 480-600 lines.

The cabinet and corresponding base should be kept from erosion, dust and water-resistant.

RSC/480-600 has placed a ring device on the top for moving convenient.

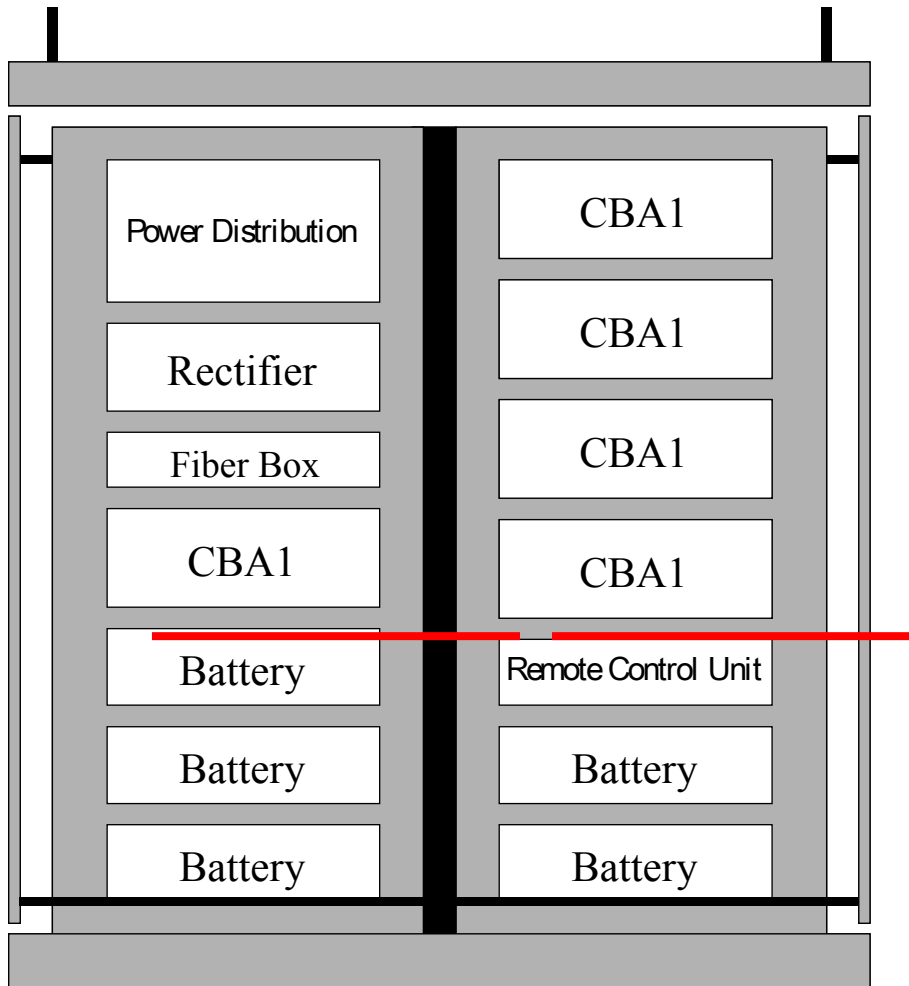

RSC/480-600 Front View

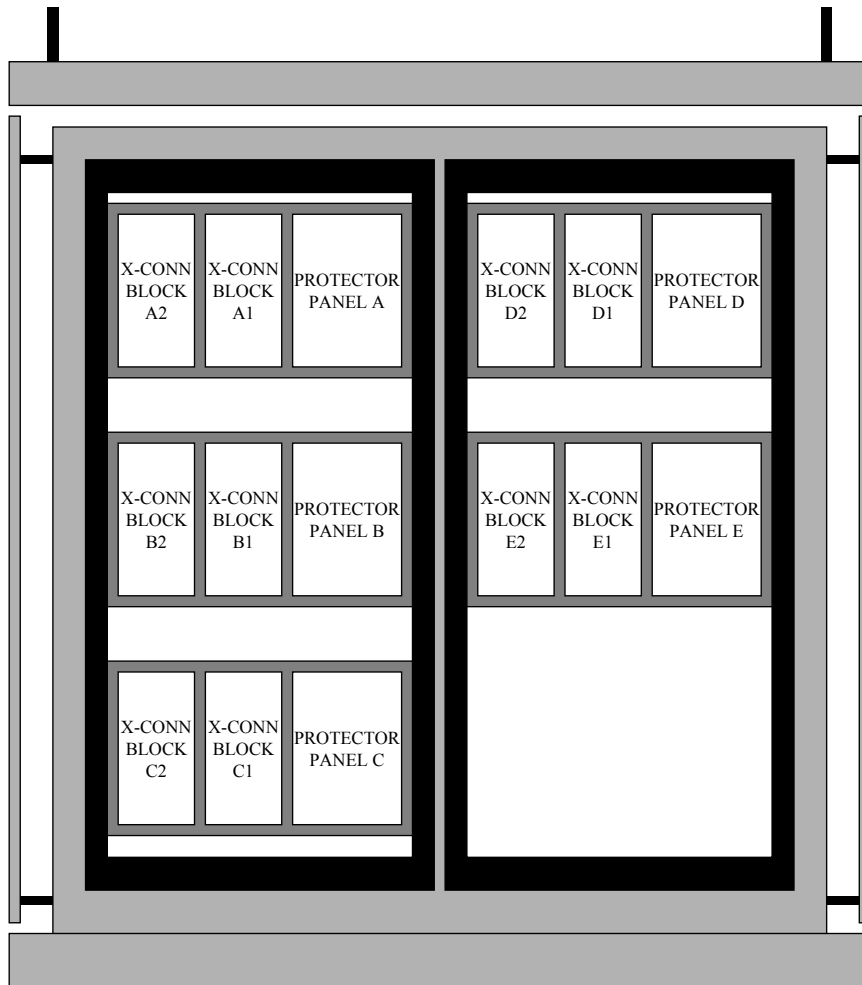

RSC/480-600 Rear View

HTC-1100E System Description

The RSC/480-600 enclosure is constructed of 1/8" powder coated aluminum. The cabinet is cooled by utilizing a double wall heat exchanger in addition to DC powered fans. The heat exchanger allows air to circulate between the inner and outer walls allowing HTC-1100E equipment compartment to maintain a favorable temperature range, even during the most inclement weather. The DC powered fan is immune to AC power failures. The combination of these design features provides HTC-1100E equipment with a technologically advanced sealed enclosure, and prevents contaminants from entering the equipment area.

The RSC/480-600 may be equipped with 48V battery strings which provide 8 to 12 hours backup capacity. The battery tray is located in the bottom of the cabinet. Battery heater/Air Condition are available for use in regions with colder/hotter climates.

The cabinet has front and rear access doors. The front door allows access to the equipment side of the cabinet. The equipment side of the RSC/480-600 may contain some or all of the following:

- Channel Bank Assemblies(Front)
- Main & Branch Circuit Breakers
- 48 V DC Power Supply
- Battery String(s)
- Twelve (12) Position Fiber Distribution Panel(s)(Fusion or Mechanical)

The front door is equipped with a key lock and pad lock tab. The rear door allows access to the splice side of the cabinet. The splice side of the RSC/480-600 may contain some or all of the following:

- Channel Bank Assembly(Rear)
- Main Ground Bus Bar
- Fiber Splicing Area and Tray(s)
- Cable Splicing Area
- E1/E1 Wire Wrap Field
- MS² Connectors
- AC Power Protection With Outlet

The rear, like the front, is equipped with a key lock and pad lock tab.

As an option, the RSC/480-600 may be equipped with a fully integrated cross connect which utilizes tool-less, punch down blocks. The RSC/480-600 may be locally powered via 110 or 220 Vac.

The RSC/480-600 is designed for pedestal mounting on a pre-cast concrete pad.

Features

- Environmental Alarms

HTC-1100E System Description

- Cabinet Designed To NEMA 4 Standards -- Prevents Contaminants From Entering Equipment Area
- DC Power Fans
- 480-600 Lines Of Capacity
- The wire to subscriber would be voltage protected by Gas-Tube
- Shake resistant and compliance with FCC 68.302 and ETSI 300 019

RSC/480-600 Specifications

Enclosure

Aluminum, powder coated, painted natural tan. Cabinet cable entry through Base plate in cable splice management area.

Powering

- Sealed Lead Acid Batteries Available for 8 to 12 Hours Backup.
- 48 Volt Battery Charger With 220/110 Volt, 50/60 Hz. Connection.
- Thermal Battery Heaters Available For Colder Climates.
- Local AC 220/110 Volt Service Entry and External Motor Generator Input.
- DC Powered Fan.
- Ground Resistance $\leq 20\Omega$
- Ground Busbar, Battery Ground and System Ground.

Environmental

Operating Temperature: -35°C to +60°C
Outside Ambient Temperature with full sunlight

Humidity: 0 - 98% non-condensing at 35°C

Mounting

Pad Mounted

Dimensions

55.5"(140.9 cm) tall by 42"(106.7 cm) wide by 31"(78.7 cm) deep
(Same measurements with or without cross connect)

4.1.5 RSC/1000

The HTC-1100E Remote Subscriber Cabinet (RSC/1000) is an environmentally controlled enclosure supporting 8 Channel Bank Assemblies (CBA). The cabinet seats on the concrete pad. The RSC1000 has a total capacity of 1000 lines.

The cabinet and corresponding base should be kept from erosion, dust and water-resistant.

RSC/1000 has placed a ring device on the top for moving convenient.

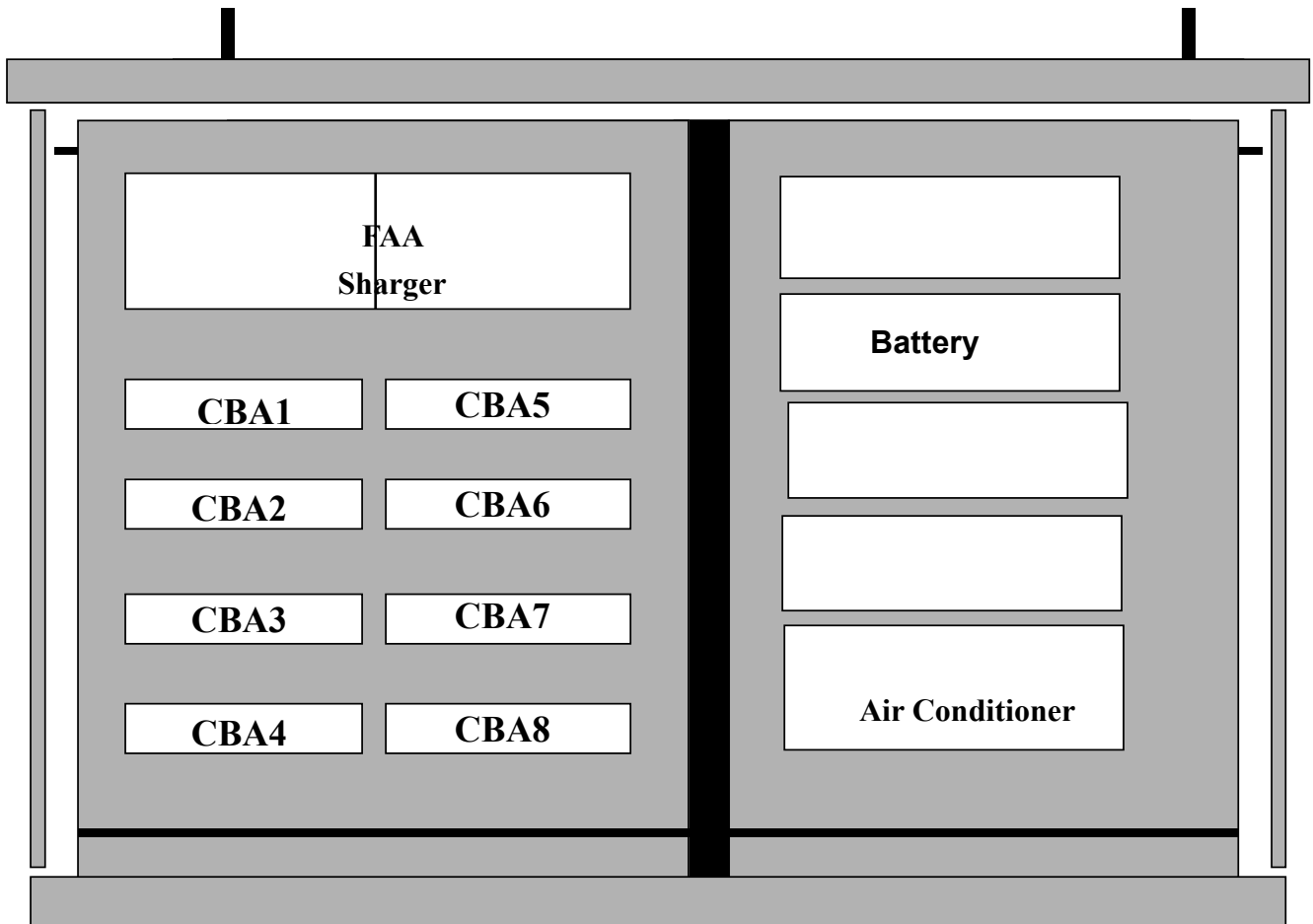

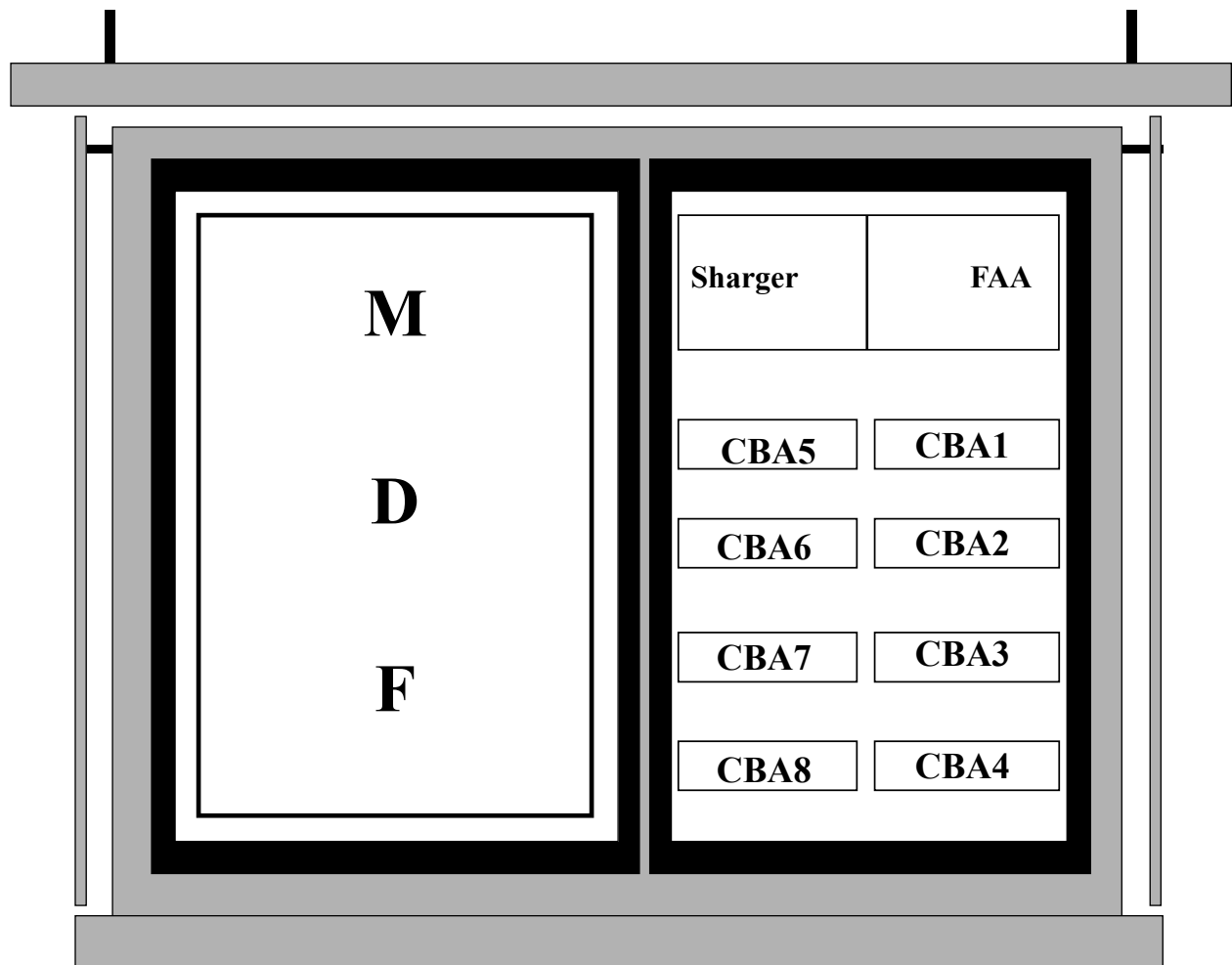

RSC/1000 Rear View

The RSC/1000 enclosure is constructed of 1/8" powder coated aluminum. The cabinet is cooled by utilizing a double wall heat exchanger in addition to DC powered fans. The heat exchanger allows air to circulate between the inner and outer walls allowing HTC-1100E equipment compartment to maintain a favorable temperature range, even during the most inclement weather. The DC powered fan is immune to AC power failures. The combination of these design features provides HTC-1100E equipment with a technologically advanced sealed enclosure, and prevents contaminants from entering the equipment area.

The RSC/1000 may be equipped with 48V battery strings which provide 8 to 12 hours backup capacity. The battery tray is located in the bottom of the cabinet. Battery heater are available for use in regions with colder climates.

The cabinet has front and rear access doors. The front door allows access to the equipment side of the cabinet. The equipment side of the RSC/480-600 may contain some or all of the following:

- Channel Bank Assemblies (Front)
- Main & Branch Circuit Breakers
- 48 V DC Power Supply
- Battery String(s)
- Twelve (12) Position Fiber Distribution Panel(s)(Fusion or Mechanical)

The front door is equipped with a key lock and pad lock tab. The rear door allows access to the splice side of the cabinet. The splice side of the RSC/1000 may contain some or all of the following:

- Channel Bank Assembly(Rear)
- Main Ground Bus Bar
- Fiber Splicing Area and Tray(s)
- Cable Splicing Area
- E1/E1 Wire Wrap Field
- MS² Connectors
- AC Power Protection With Outlet

The rear, like the front, is equipped with a key lock and pad lock tab.

As an option, the RSC/1000 may be equipped with a fully integrated cross connect which utilizes tool-less, punch down blocks. The RSC/1000 may be locally powered via 110 or 220 Vac.

The RSC/480-600 is designed for pedestal mounting on a pre-cast concrete pad.

Features

- Environmental Alarms
- Cabinet Designed To NEMA 4 Standards -- Prevents Contaminants From Entering Equipment Area
- DC Power Fans
- 1000 Lines Of Capacity
- The wire to subscriber would be voltage protected by Gas-Tube
- Shake resistant and compliance with FCC 68.302 and ETSI 300 019

RSC/1000 Specifications

Enclosure

Aluminum, powder coated, painted natural tan. Cabinet cable entry through Base plate in cable splice management area.

Powering

- Sealed Lead Acid Batteries Available for 8 to 12 Hours Backup.
- 48 Volt Battery Charger With 220/110 Volt, 50/60 Hz. Connection.
- Thermal Battery Heaters Available For Colder Climates.
- Local AC 220/110 Volt Service Entry and External Motor Generator Input.
- DC Powered Fan.
- Ground Resistance $\leq 20\Omega$
- Ground Busbar, Battery Ground and System Ground.

Environmental

Operating Temperature: -35°C to +60°C

Outside Ambient Temperature with full sunlight

Humidity: up to 98% non-condensing at 35°C

Mounting

Pad Mounted

Dimensions

160.0 cm tall by 160.0cm wide by 57.0cm deep

(Same measurements with or without cross connect)

4.2 Common Units

4.2.1 Central Processing Unit (CPU)

The Central Processing Unit (CPU) is responsible for the overall control of HTC-1100E. Identical CPU's are used at both the LET and all RST's. The CPU performs system initialization, provisioning, alarm reporting, Maintenance, diagnostics, and fault detection. In addition, it performs timing source selection, synchronization to external timing sources. It also provides a high stability internal timing reference. The faceplate is featured on this page.

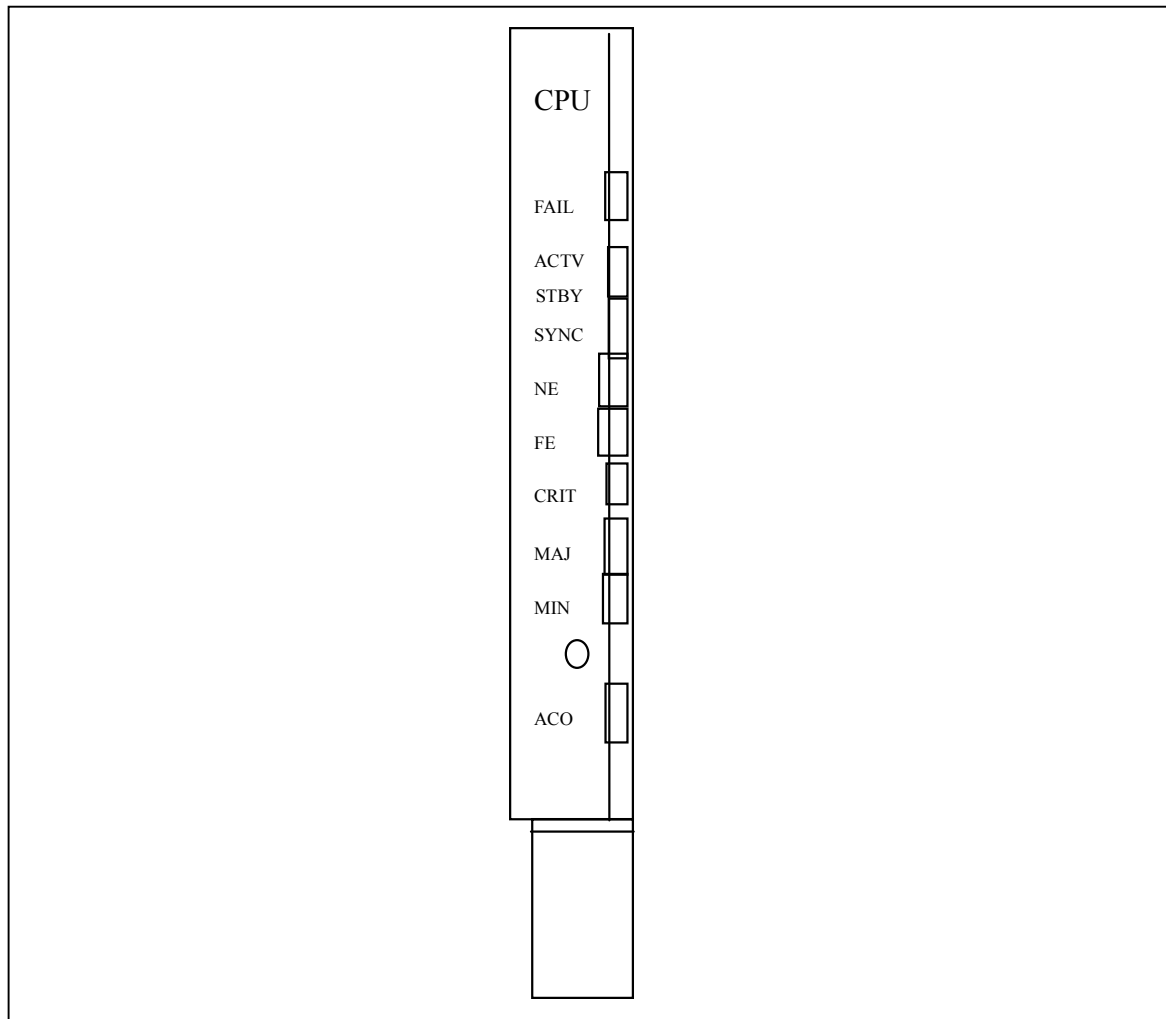

The CPU controls call processing for HTC-1100E system. The CPU allocates timeslots for subscribers who have gone off-hook, cancels timeslots for terminated calls, relays provisioning information to and from subscriber interfaces and provides automatic concentration during span failures.

The CPU also runs the Craft Interface. It is accessed either through the standard RS232-C port located on the Air Ramp portion of the Channel Bank Assembly, or on wire wrap pins on the backplane. Connecting to the Craft Interface port with a simple terminal, such as a VT 100, allows administration, Maintenance, testing, and provisioning to be performed using HTC-1100E's menu-driven Craft Interface.

One CPU is located at the Local Exchange Terminal and one at each RST. In an optional redundant configuration, an additional CPU may be equipped at each terminal.

There are nine LEDs on the face plate of the CPU.

- The green ACTV and the yellow STBY LEDs indicate which CPU is active and which CPU is in standby when a terminal is equipped with redundant CPUs.
- The red FAIL LED indicates when the CPU is not functioning properly.
- The blue SYNC LED indicates when the active unit has acquired synchronization.
- The yellow NE LED provides indication that a near end alarm is active in the system.
- The yellow FE LED indicates the presence of a far end alarm in the system.
- The red CRIT LED indicates the presence of an critical alarm in the system.
- The red MAJOR LED provides indication of a Major alarm in the system.
- The yellow MINOR alarm indicates a minor alarm is present.
- The green ACO LED indicates that the audible alarm has been silenced but that the alarm has not yet cleared. In addition to these LEDs the faceplate also house the alarm cutoff (ACO) switch.

Features

- Provides common control for the entire HTC-1100E system
- Craft Interface
- Provides access to all remote terminals
- Alarm generation and prioritization
- System Maintenance and Administration
- Non-volatile provisioning data storage
- Diagnostics and Fault localization
- Timing source selection and synchronization

CPU Specification

CPU

Microprocessor	Motorola MC68331
Program Data Store	EEPROM (1 Mbyte)
Provisioning Data Store	EEPROM (256 Kbytes)
RAM Store	SRAM (512 Kbytes)

Timing Generator

External Clock Sources Selection:

- (1) Slot Selectable
- (2) 64 Kbps clock (Option)
- (3) External 2.048 clock source

Locks to G.703 1.2.2 Centralized Clock Interface or any incoming digital facility with 50 ppm accuracy.

Internal Clock

Initial accuracy	±10 Hz
Stability	16.384 MHz±20 ppm (15 yrs)

Environmental

Operating temperature	-35°C to +60°C
Humidity	up to 98% at 35°C
Maximum Power Consumption	2.8 W

Dimensions

5.125" (13.018 cm) tall (standing up in CBA)
 10.5" (26.67 cm) long (from front of CBA to CBA backplane)
 0.563" (1.429 cm) thick (measured along faceplate thickest point)

Weight

0.5 lbs (0.23 Kilograms)

Compliance

Jitter tolerance ITU-T G.703

4.2.2 Expansion Bank Control (EBC)

The Expansion Bank Control (EBC) provides the microprocessor based monitoring and control for the Expansion shelf if it is installed in. It provides the interface to the system for each of the cards in the shelf via a fiber optic connection to the Primary shelf based Expansion Link Unit. The EBC distributes system commands as well as monitors the performance of each card. The EBC resides in the Expansion shelf in the slots utilized by the CPU in the Primary Shelf. A second common control slot is available for redundancy. Its faceplate is shown on this page.

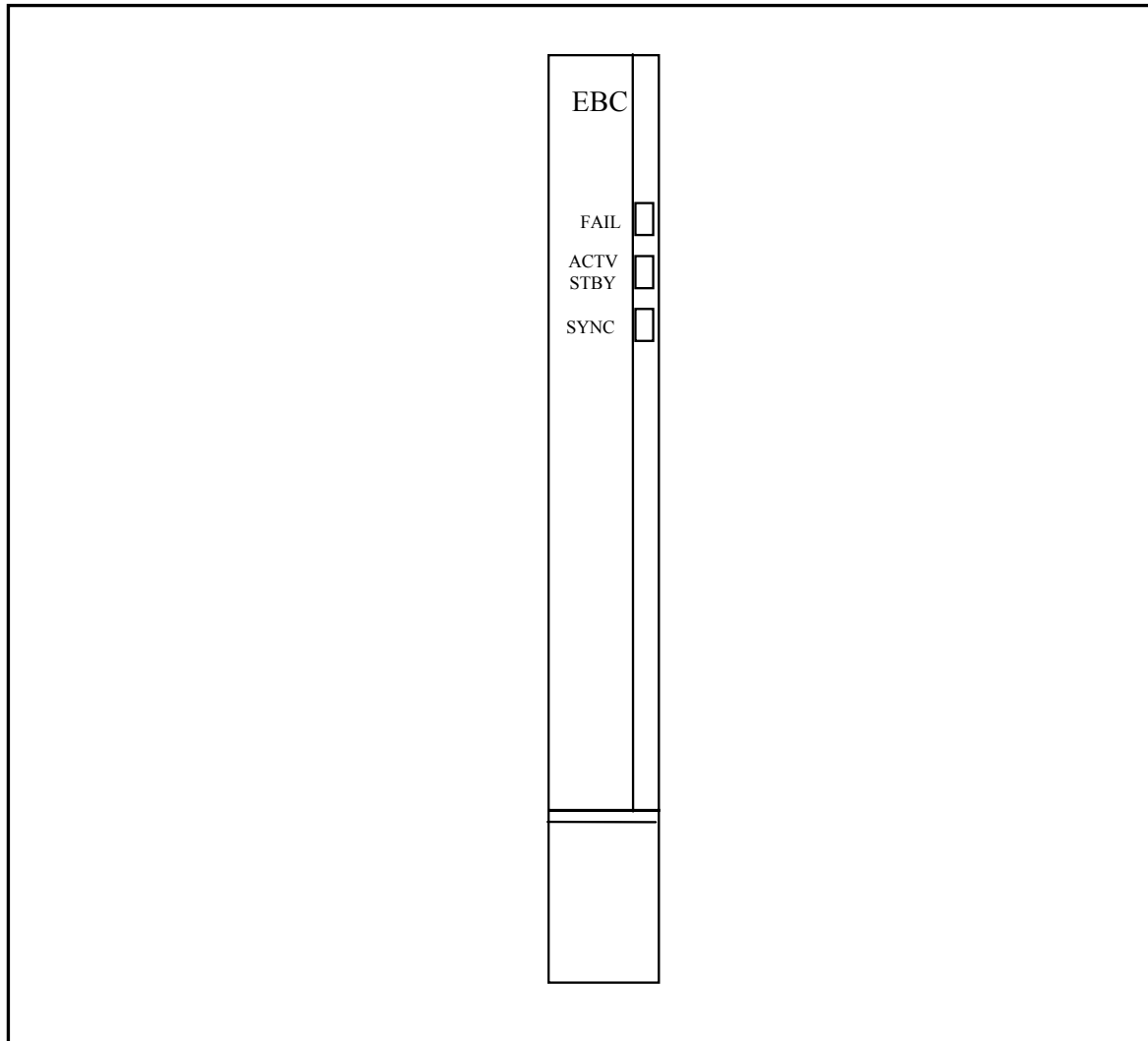

The connection between the ELU and the EBC operates at 49.152 Mbps to ensure full non-blocking access to the transmission facility regardless of the types of channel cards used in the Expansion CBA. The EBC provides front access for the fiber connection to the ELU.

The fiber optic cable used between the EBC (in the expansion shelf) and the ELU (in the primary shelf) is plastic. Plastic is used because it is more durable.

LED's located on the ELU front panel indicate ACTV (green), FAIL (red), and SYNC (blue). The unit also provides alarm interface to the CPU via the ELU.

Features

- Straight forward system expansion
- Interface to ELU in Primary Shelf
- Shelf Control for Expansion Shelves
- Generates Status updates to the CPU via the ELU
- CRC protection on the expansion link

EBC Specification	
<u>Interface Specification</u>	
Transmission Rate:	49.152 Mbps
Transmitter	LED
Receiver	PIN FET
Coding	Differential NRZI
Fiber type	Multi-mode Plastic
Connector type	HP "Versa-link"
<u>Environmental</u>	
Operating temperature	-35°C to +60°C
Humidity	up to 98% at 35°C
Maximum Power Consumption	7.0 W
<u>Dimensions</u>	
	5.125" (13.018 cm) tall (standing up in CBA)
	10.5" (26.67 cm) long (from front to backplane of CBA)
	0.563" (1.429 cm) thick (along faceplate - thickest point)
<u>Weight</u>	
	0.5 lbs (0.23 Kilograms)

4.2.3 Expansion Link Unit (ELU)

The Expansion Link Unit (ELU) provides the system connection from the Primary shelf to each of the Expansion shelves. One ELU (two for redundancy) is dedicated to each expansion shelf. It provides the fiber optic connection to the Expansion shelf based EBC. It transmits system commands from the CPU to its dedicated Expansion shelf. It likewise receives information from the EBC and relays it to the CPU. The ELU may reside in any of the 22 general-purpose slots in the Primary shelf. Its faceplate is shown on this page.

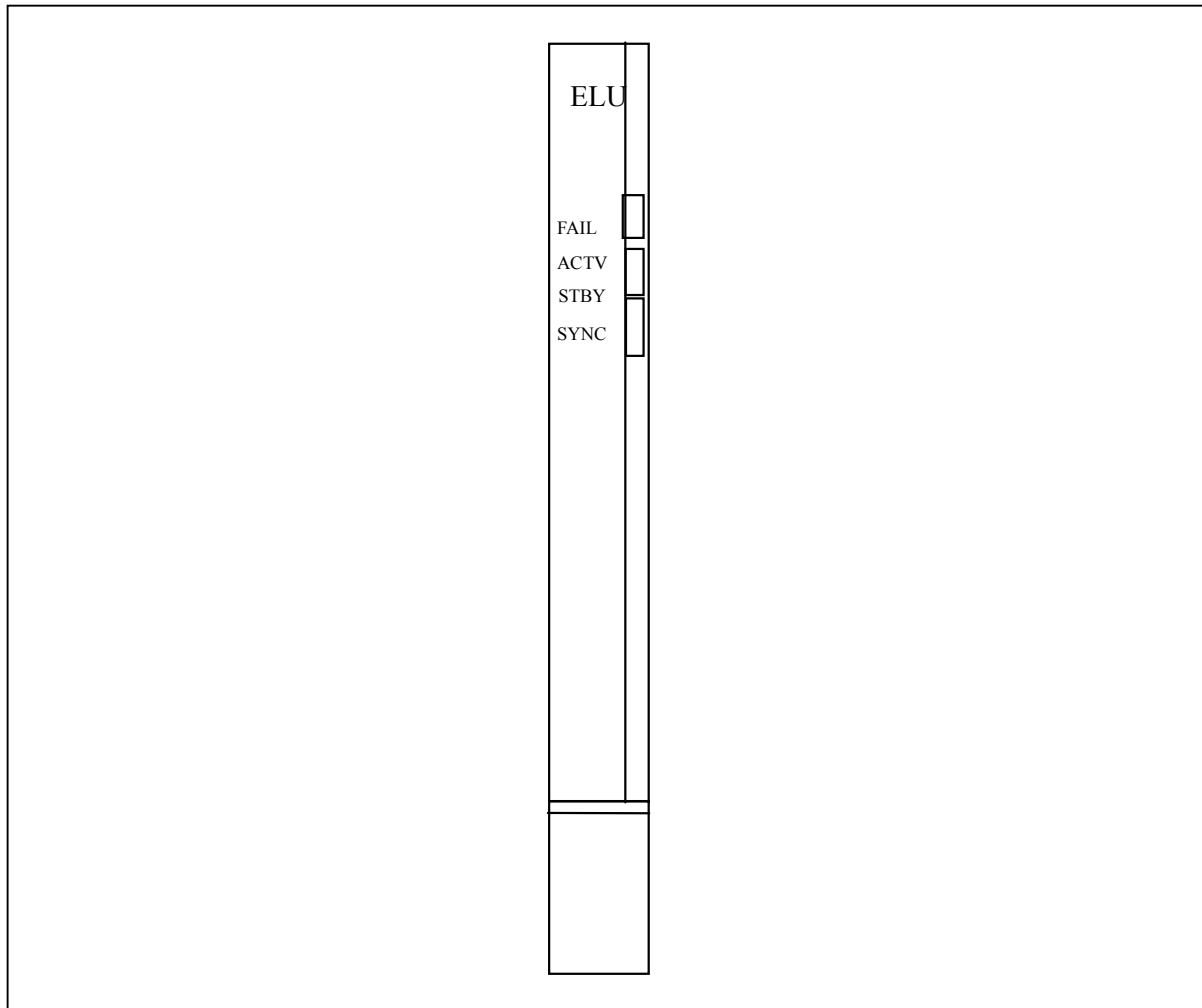

The connection between the ELU and the EBC operates at 49.152 Mbps to ensure full non-blocking access to the transmission facility regardless of the types of channel cards used in the Expansion CBA. The ELU provides front access for the fiber connection.

LED's located on the ELU front panel indicate ACTV (green), FAIL (red), and SYNC (blue). The unit also provides alarm status from the Expansion CBA to the CPU.

Features

- Straight forward system expansion
- Interface to ELU in Primary Shelf
- Communications gateway between the CPU and the Expansion Shelves
- Microprocessor controlled
- Non-blocking inter-shelf connection
-

ELU Specification

Interface Specification

Transmission Rate:	49.152 Mbps
Transmitter	LED
Receiver	PIN FET
Coding	Differential NRZI
Fiber type	Multi-mode Plastic
Connector type	HP "Versa-link"

Environmental

Operating temperature	-35°C to +60°C
Humidity	up to 98% at 35°C
Power Consumption	7.0 W

Dimensions

5.125" (13.018 cm) tall (standing up in CBA)
 10.5" (26.67 cm) long
 (from front of CBA to CBA backplane)
 00.563" (1.429 cm) thick (along faceplate thickest point)

Weight

0.5 lbs (0.23 Kilograms)

4.2.4 Local Exchange Terminal Power Supply Unit

The Local Exchange Terminal Power Supply Unit (L-PSU) converts the exchange battery input into the voltages required by HTC-1100E Local Exchange Terminal Common control equipment and line cards. It uses a DC to DC switching converter for high efficiency and low thermal dissipation. Only one L-PSU is required to power each LET shelf; however, an additional card slot is provided for a redundant L-PSU. Its faceplate is shown on this page.

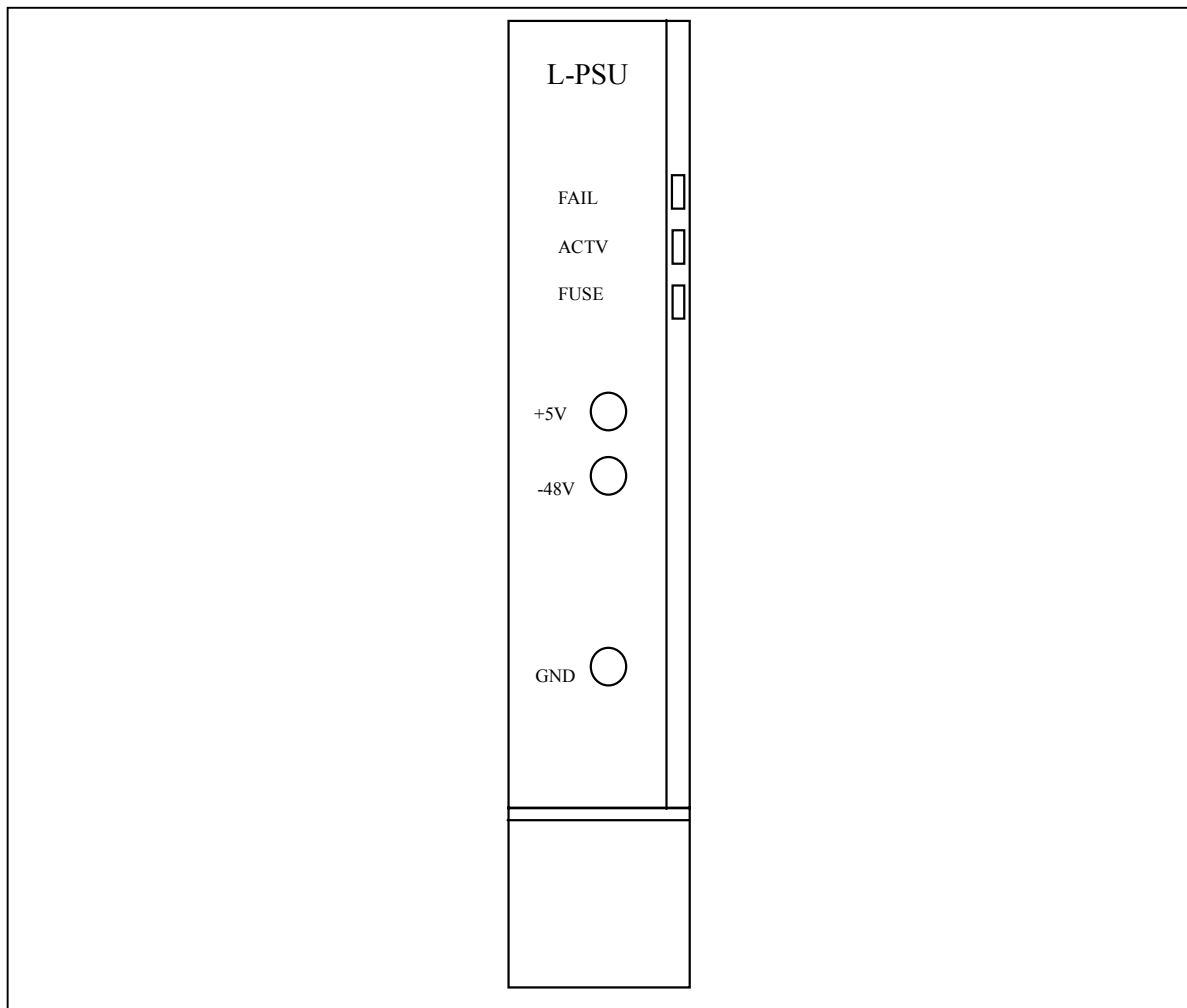

The L-PSU's provide the load sharing capability so that the system can operate when a failure occurs on either of the L-PSU's.

LED's located on the PSU front panel indicate ACTV (green), FUSE (red), and FAIL (red). The unit also provides alarm and status indications to the CPU. Test jacks on the front panel allow the monitoring of system voltages.

Features

- High Efficiency Switching DC-DC converter
- Reverse polarity protection
- Over-voltage / Over-Current shutdown

- Low Voltage alarm
- Low thermal dissipation
- Low voltage disconnect

L-PSU Specification	
<u>DC-DC Converter</u>	
Input	-42 V to -63 V DC
Output	+5.15V±1.5%
	-5.15V±10.0%
	-32.0V Line battery±10.0%
<u>Regulation</u>	±5.15V < 1.5% load < 1.5% line < 0.2% per temperature range specified below
<u>Ripple and Noise</u>	
(DC-20 MHz)	±5V 1.0% pk-pk
<u>Output Current:</u>	
+5V	15 Amp
-5V	2 Amp
-32V	3 Amp
<u>Isolation</u>	
500V Input to Output	
<u>Environmental</u>	
Operating temperature	-35°C to +60°C
Humidity	up to 98% at 35°C
<u>Dimensions</u>	
5.125" (13.018 cm) tall (standing up in CBA)	
10.5" (26.67 cm) long (from front of CBA to CBA backplane)	
1.0" (2.54 cm) thick (along faceplate - thickest point)	
<u>Weight</u>	1.0 lbs (.45 Kilograms)

4.2.5 Remote Subscriber Terminal Power Supply Unit

The Remote Subscriber Terminal Power Supply Unit (R-PSU) converts the -48V rectifier input into the voltages required by the common control equipment and line cards located at the RST. In addition, the R-PSU generates sine wave ringing voltage for use by the subscriber interfaces. The output frequency is software provisionable. The R-PSU uses a DC to DC switching converter for high efficiency and low thermal dissipation. Only one R-PSU is required to power an RST shelf; however, an additional card slot is provided for a redundant R-PSU. Its faceplate is shown on this page.

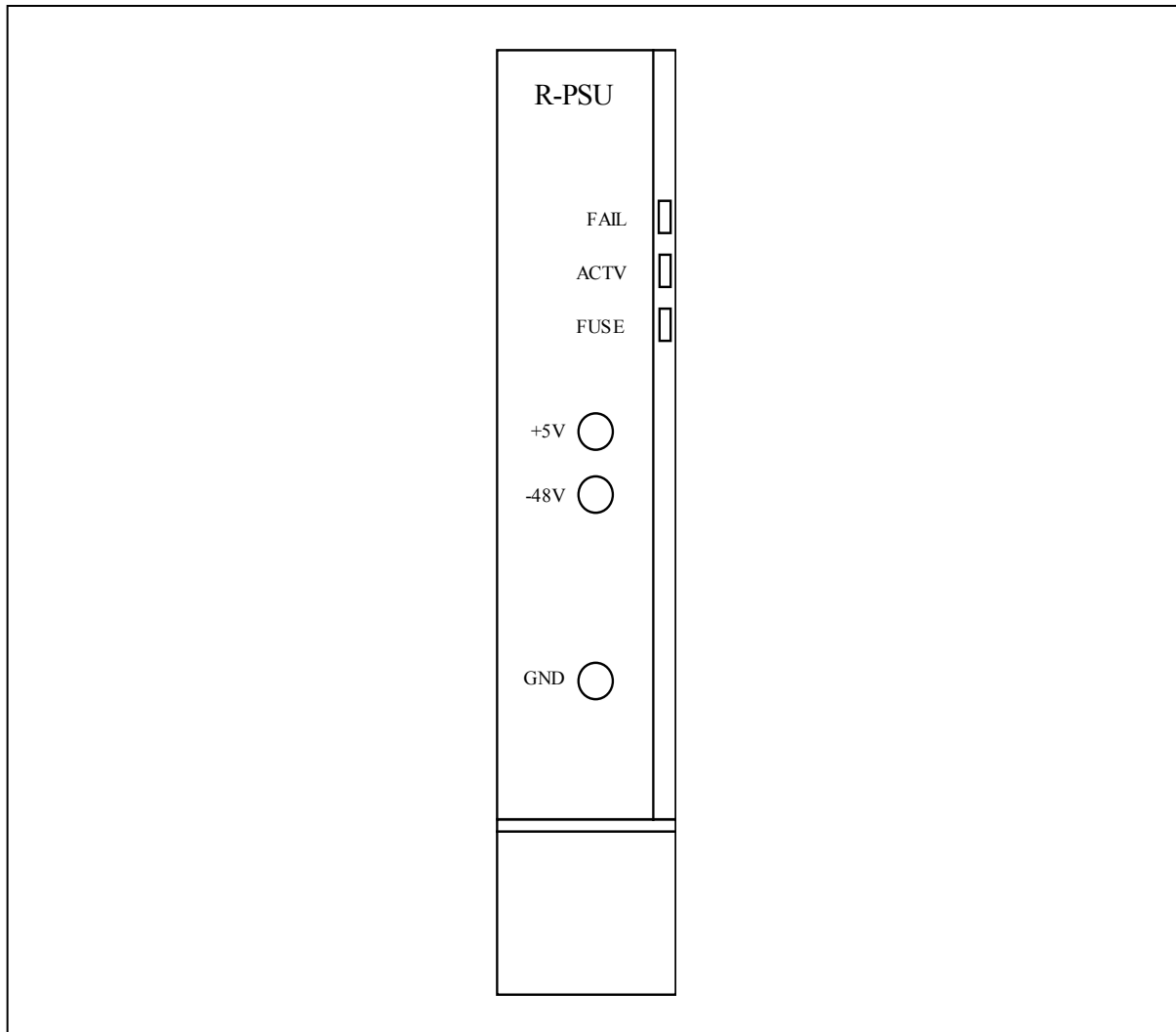

The R-PSU's uses active load sharing to provide uninterrupted service if one unit should fail. The ringing generator provides single ended inquiry.

LED's located on the R-PSU front panel indicate ACTV (green), FUSE (red), and FAIL (red). The unit also provides alarm and status indications to the CPU. Test jacks on the front panel allow the monitoring of system voltages.

Features

- High Efficiency Switching DC-DC converter
- Software Provisionable ringing frequency (20 to 30 Hz)
- Reverse polarity protection
- Over-voltage / Over-Current shutdown
- Low Voltage alarm
- Low thermal dissipation
- Low voltage disconnect

R-PSU Specification	
<u>DC-DC Converter</u>	
Input	-42.0V to -63.0V DC
Output	+5.15V±1.5%
	-5.15V±10.0%
	-52.0V Battery ±10% (Long Line Talk Battery)
<u>Regulation</u>	±5.15V < 1.5% load
	< 1.5% line
	< 0.2% per temperature range specified below
<u>Ripple and Noise</u>	±5V 1.0% pk-pk
(DC-20 MHz)	-52V < 50 mV pk-pk
<u>Output Current:</u>	+5V 15 Amp
	-5V 2 Amp
	-52V 2 Amp
	-32V 3 Amp
<u>Isolation</u>	500V Input to Output
<u>Ring Generator</u>	-48V Pedestal
Output Voltage	(provisionable) 60, 65, 85, or 95 Vrms
Voltage Tolerance	±5%
Output frequency	(provisionable) 20 Hz to 30 Hz
Frequency tolerance	±2.5%
<u>Environmental</u>	
Operating temperature	-35°C to +60°C
Humidity	up to 98% at 35°C
<u>Dimensions</u>	
	5.125" (13.018 cm) tall (standing up in CBA)
	10.5" (26.67 cm) long (from front of CBA to CBA backplane)
	1.0" (2.54 cm) thick (measured along faceplate - thickest point)
<u>Weight</u>	1.0 lbs (.45 Kilograms)

4.2.6 Metallic Test Unit

The Metallic Test Unit is an optional plug-in assembly, which may be used to provide enhanced testing, and diagnostic capabilities for HTC-1100E. The MTU allows metallic Maintenance access to both the facility and equipment side of a customer's line for craft access. Drop side (facility) testing is also performed by the MTU. Its faceplate is shown on this page.

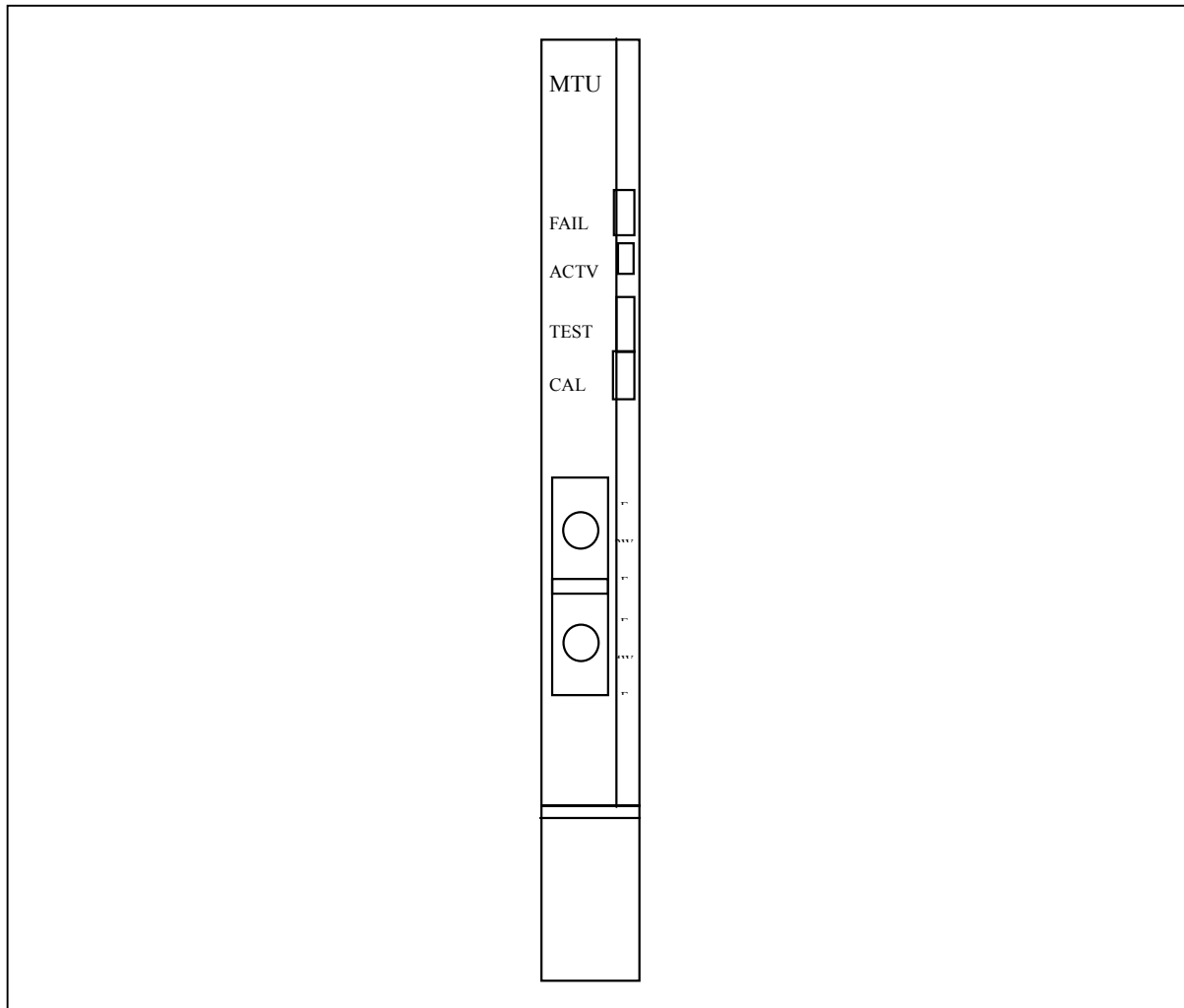

The MTU is used to test outdoor cable and has the capacity to test all analog channel units at an RST. The MTU provides basic metallic access, an order wire interface, a remote line test head, and extensive internal diagnostics measurement capabilities. The MTU eliminates the need for a remote test head.

The internal test capabilities of the MTU include the ability to test for hazardous voltages, open circuit, short circuit, and 3 terminal complex impedance (Resistance and Capacitance) Dimensions.

LED's located on the MTU front panel indicate ACTV (green), TEST (blue), CAL (yellow), and FAIL (red). The unit also provides alarm and test status indications to the CPU. Test jacks on the front panel allow the monitoring of the facility and equipment pairs under test.

The MTU also provides faceplate bantam jacks which provide metallic loop access and access into the system.

Besides, HTC-1100E could activate and deactivate loop testing for analog and digital channel units in RST by issuing in LET side.

Features

- Drop line testing
- Foreign Voltage: Range:0-200Vrms, Accuracy: $\pm(15\%+1\text{dgts})$
- Hazardous Voltage: Range:0- \pm 200V, Accuracy: $\pm(15\%+1\text{dgts})$
- Loop Resistance: Range: 0-3K Ohm, Accuracy: $\pm(10\%+1\text{dgts})$
- Insulation Resistance: Range: 10K-1M Ohm, Accuracy: $\pm(10\%+1\text{dgts})$
- Capacitance: Range:0.1 ~ 5 uF, Accuracy: $\pm(10\%+1\text{dgts})$
- Ringing and ringing detection
- Interface for External Test Systems
- Provides front jack access to metallic loop facility and equipment
- Coordinate with 112 testing station (e.g. ring testing, howler tone when customer on-hook improperly finished)
- Provide wire antithesis testing for outside testing staff
- Incorporate with NMI (Network Management Interface) card, in order that Fault Repair system could access HTC-1100E to do its job via Ethernet network.
-

MTU Specification

Subscriber Drop Tests

Hazardous Voltage	±400V peak to peak, 250 Vrms±10%
Foreign voltage	±1V to ±4VDC or 25rms±10%
Short Circuits	< 100Ω±10%
Open Circuits	> 1 MegΩ±10%
Capacitance	0.1 μF < C < 5μF+10%
Leakage T-Gnd	> 1 MegΩ±10%
Leakage R-Gnd	> 1 MegΩ±10%
Leakage T-R	> 1 MegΩ±10%

Environmental

Operating temperature	-35°C to +60°C
Humidity	up to 98% at 35°C
Max Power Consumption	2.6W

Dimensions

5.125" (13.018 cm) tall (standing up in CBA)
 10.5" (26.67 cm) long (from front of CBA to CBA backplane)
 0.563" (1.429cm) thick (measured along faceplate thickest point)

Weight

0.5 lbs (0.23 Kilograms)

4.2.7 Analog Test Unit (ATU)

The Analog Test Unit is an optional plug-in on LET or RST assembly for operator to test that provide enhanced testing and diagnostic capabilities for HTC-1100E without external associative test accessories/equipment. The ATU provide metallic maintenance access to the facility and equipment side of a customer's line for craft access. The ATU ability to test a customer drop allow the unit to be used an economic alternative to expensive Remote side test and Diagnostics equipment. Its faceplate is shown on this page.

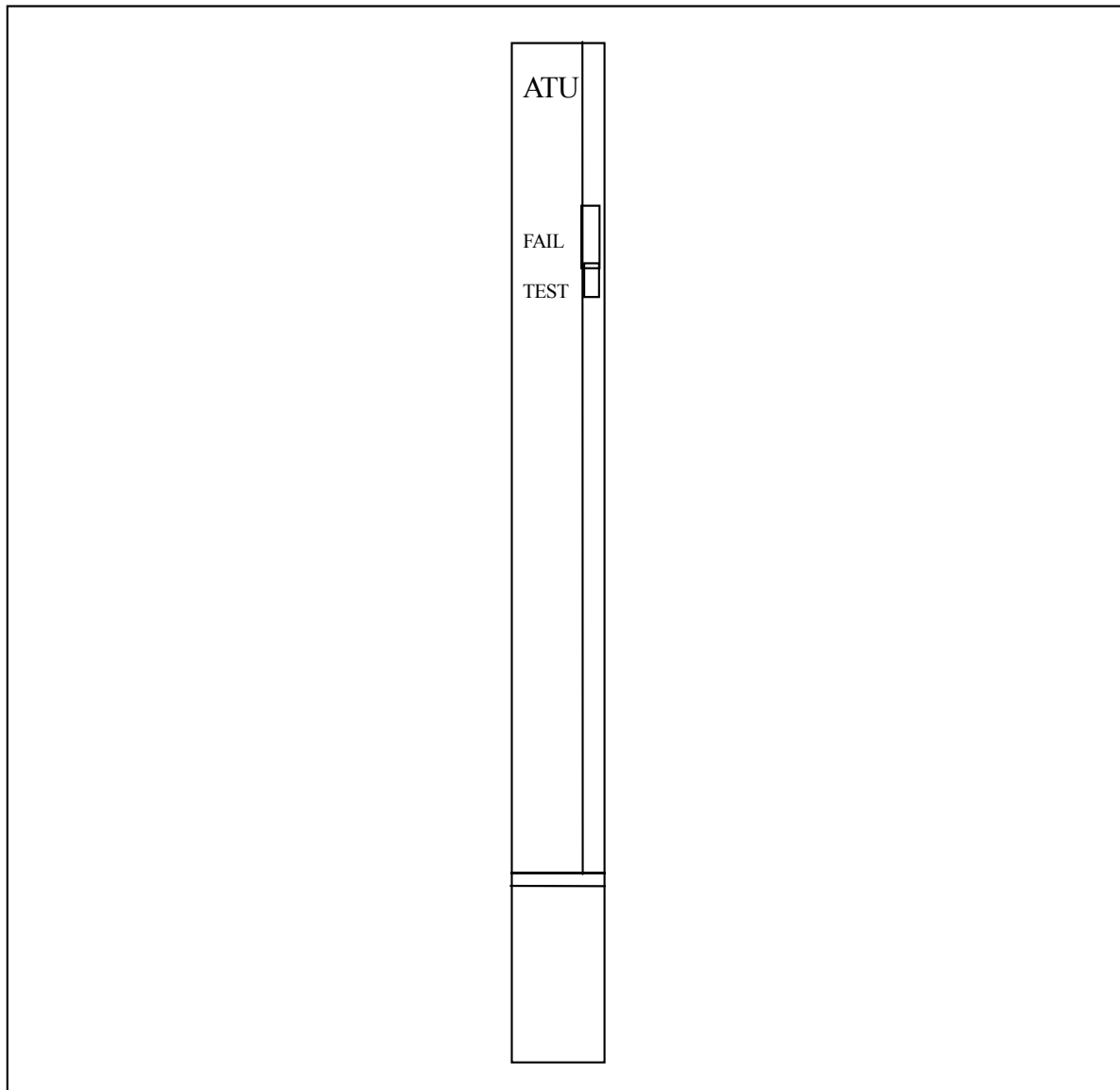

The ATU is used to test outdoor cable and has the capacity to test all analog channel units at an RST. The drop test capabilities include 3 terminals (tip-ring, tip-ground, ring ground) for AC voltage, DC voltage, Resistance and Capacitance. It also can be plug-in on LET to test Loop current, DC voltage, DT/DTD (Dial tone/Dial tone disconnect), and V-port monitor function and provide inner test to check if transmission path from Exchange to LET and LET to RST have any problem by sending or Receiving analogy signal.

The ATU provides basic metallic access, an order wire interface, a remote line test head, and

extensive internal diagnostics measurement capabilities. The ATU eliminates the need for a remote test head.

There are two LED located on the front panel .The green TEST LED indicates that the ATU card is ready for use .The red Fail LED is on continuously when the ATU fails or can not communicate with CPU. The unit also provides alarm and test status indications to the CPU

Features

- Drop line testing
- AC Voltage: Range:0-200Vrms(50-500Hz), Accuracy: $\pm(15\%+1\text{dgts})$
- DC Voltage: Range:0-200V, Accuracy: $\pm(15\%+1\text{dgts})$
- Loop Resistance: Range: 0-3K Ohm, Accuracy: $\pm(10\%+1\text{dgts})$
- Insulation Resistance: Range: 10K-1M Ohm, Accuracy: $\pm(10\%+1\text{dgts})$
- Capacitance: Range:0.1 ~ 5 uF, Accuracy: $\pm(10\%+1\text{dgts})$
- Loop current: Impedance 600Ωn, Accuracy: $\pm(3\%+1\text{dgts})$
- Tx /Rx Level & frequency test
- Ringing Voltage test: 80Vrms
- Coordinate with 112 testing station (e.g. ring testing, DT/DTD, howler tone when customer on-hook improperly finished)
- V-port monitor function
- Incorporate with NMI (Network Management Interface) card, in order that Fault Repair system could access HTC-1100E to do its job via Ethernet network.

ATU Specification

Subscriber Drop Tests

Hazardous Voltage	$\pm 400V$ peak to peak, 250 Vrms $\pm 10\%$
Foreign voltage	$\pm 1V$ to $\pm 4VDC$ or 25rms $\pm 10\%$
Short Circuits	$< 100\Omega \pm 10\%$
Open Circuits	$> 1 \text{ Meg}\Omega \pm 10\%$
Capacitance	$0.1 \mu F < C < 5\mu F + 10\%$
Leakage T-Gnd	$> 1 \text{ Meg}\Omega \pm 10\%$
Leakage R-Gnd	$> 1 \text{ Meg}\Omega \pm 10\%$
Leakage T-R	$> 1 \text{ Meg}\Omega \pm 10\%$

Environmental

Operating temperature	$-35^{\circ}C$ to $+60^{\circ}C$
Humidity	up to 98% at $35^{\circ}C$
Max Power Consumption	2.6W

Dimensions

5.125" (13.018 cm) tall (standing up in CBA)
 10.5" (26.67 cm) long (from front of CBA to CBA backplane)
 0.563" (1.429cm) thick (measured along faceplate thickest point)

Weight

0.5 lbs (0.23 Kilograms)

4.3 Transceiver Unit

4.3.1 Line Powering E1 Transceiver (E1-XCVR)

The HTC-1100E Line Powering E1 Transceiver provides a E1 cable interface, transmitting and receiving up to 30 Basic 64 Kbps channels of voice or data originating from either the channel unit in the subscriber slots or another E1 transceiver. The E1-XCVR may be used at either the Local Exchange Terminal or Remote Subscriber Terminals. It operates at the ITU-T rate of 2.048 Mbps. It has an Automatic Line Build Out (Attenuation) function on its receive side and four discrete Line Build Out settings on its transmit side. These settings are provisionable through software using HTC-1100E craft interface. Its faceplate is shown on this page.

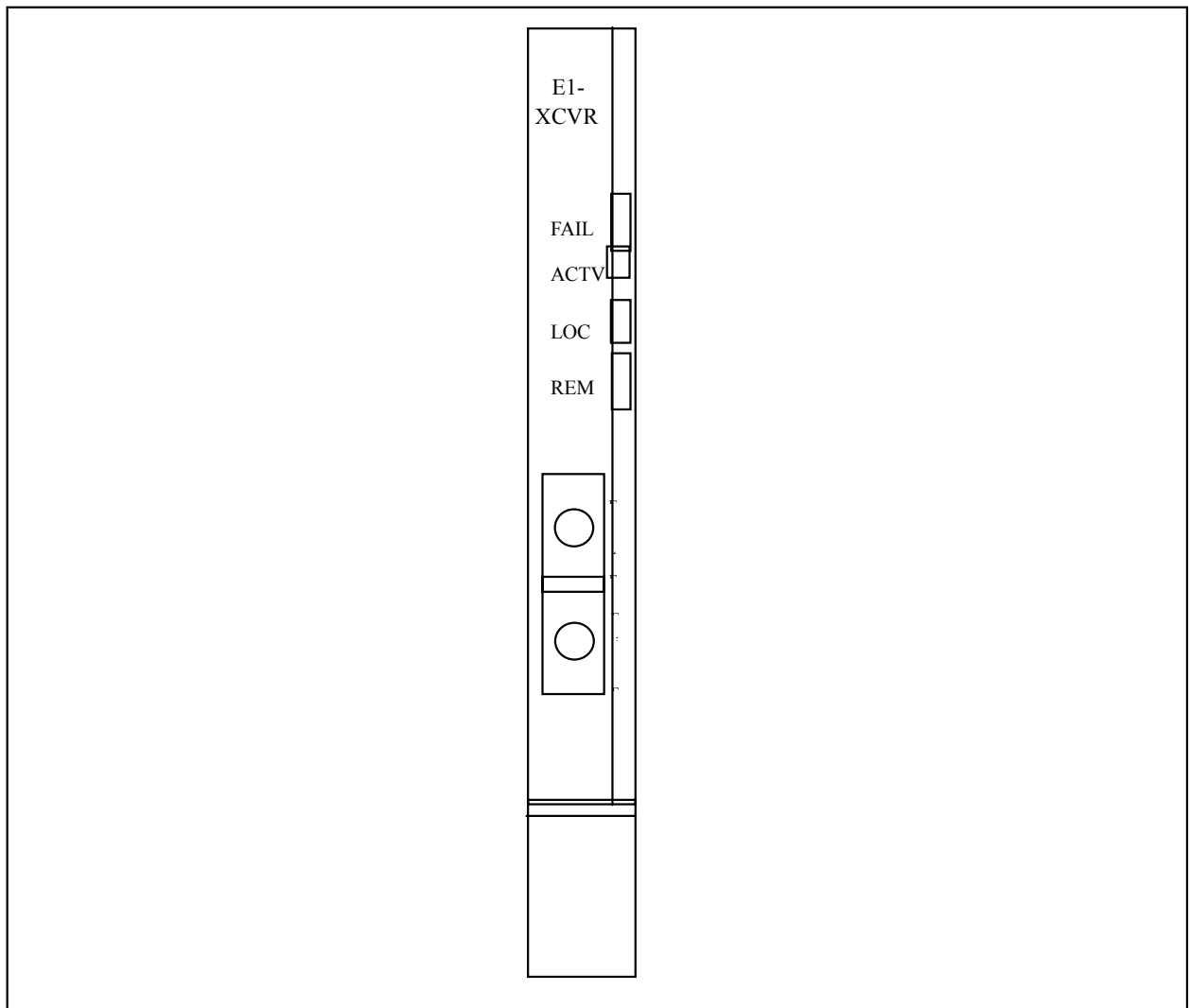

The Line Powering E1 Transceiver performs signaling conversion and data link termination. The line coding is HDB3. The transceiver has selectable alarm thresholds, BER calculation, performance monitoring statistics, and alarm history.

The E1-XCVR may also be used in LET or RST as a service card which provides a single, channelized, line-powering E1 to a customer via OSP facilities.

The Line Powering E1 Transceiver has a power feed system (60 mA constant current source) to power span line repeaters in any of several power feed options. These include end-to-end, midspan or span terminating configurations. The number of repeaters powered is a function of the repeater voltage and wire gauge used between repeaters. The external power feed resistance of the E1 should not exceed a 2000 Ω equivalent resistance.

Assuming a 7 volts drop across repeaters and .6 mm (22 gauge) cable at approximately 1.8 km between repeaters, the E1-XCVR will power up to seven repeaters. The E1-XCVR also provides loop back and sealing current.

There are four LED indicators on the Line Powering E1 Transceiver front panel. A green ACTV LED indicates the unit is busy and must not be unplugged without first removing traffic. A red FAIL LED indicates that the unit has failed. An amber REM LED indicates that the unit is in Far End Alarm, and another amber LOC LED indicates that the unit is in Near END alarm. The transceiver features front panel jack access for testing and monitoring.

Features

- One, Line Powering E1 Interface per card
- Double frame, CRC multi-frame formats
- Extensive Loopback Diagnostics
- Front panel jack access for test and monitoring
- Low power dissipation
- May be used to deliver fractional E1 to customers or for groomed services
-

Line Powering E1 Transceiver Specification	
<u>Signaling</u>	
Line Rate	2.048 Mbps ± 50 ppm
Framing Formats	Double frame, CRC multi-frame
Line Coding	HDB3
Channel sequence	CAS or CCS
Error Checking	CRC4
Loopback Modes	Local, Remote
<u>Analog Parameters</u>	
Equalization	Receive Automatic Line Build Out (38 dB attenuation) Transmit Fixed 3.0 Vpk±0.3 Vpk
Input Impedance	120Ω(twisted pair)
<u>Powering</u>	
Output Current	60 mA±2 mA
Output Voltage(open circuit)	-130 V±5 V
Output Noise(DC-20 MHz)	< 10 mV pk-pk
External Power Feed Resistance	≲2000Ω
<u>Environmental</u>	
Operating temperature	-35°C to +60°C
Humidity	up to 98% at 35°C
Max Power Consumption	12.1 W
<u>Dimensions</u>	
	5.125" (13.018 cm) tall (standing up in CBA)
	10.5" (26.67 cm) long (from front of CBA to CBA backplane)
	0.563" (1.429 cm) thick (measured along faceplate - thickest point)
<u>Weight</u>	
	0.5 lbs (0.23 Kilograms)
<u>Compliance</u>	
Jitter	ITU-T G.703 I.431 Draft
Cable Interface	ITU-T G.703

4.3.2 E1 Transceiver (E1X-XCVR)

The HTC-1100E E1 Transceiver provides an indoor E1 (G.703) level interface, transmitting and receiving up to 30 Basic 64 Kbps channels of voice or data originating from either the channel unit or another E1 transceiver. The E1-XCVR may be used at either the channel units or another E1 transceiver. It operates at the E1 rate of 2.048 Mbps. The E1X-XCVR is intended for use in applications requiring interface to multiplexers or other co-located office equipment. Its faceplate is shown on this page.

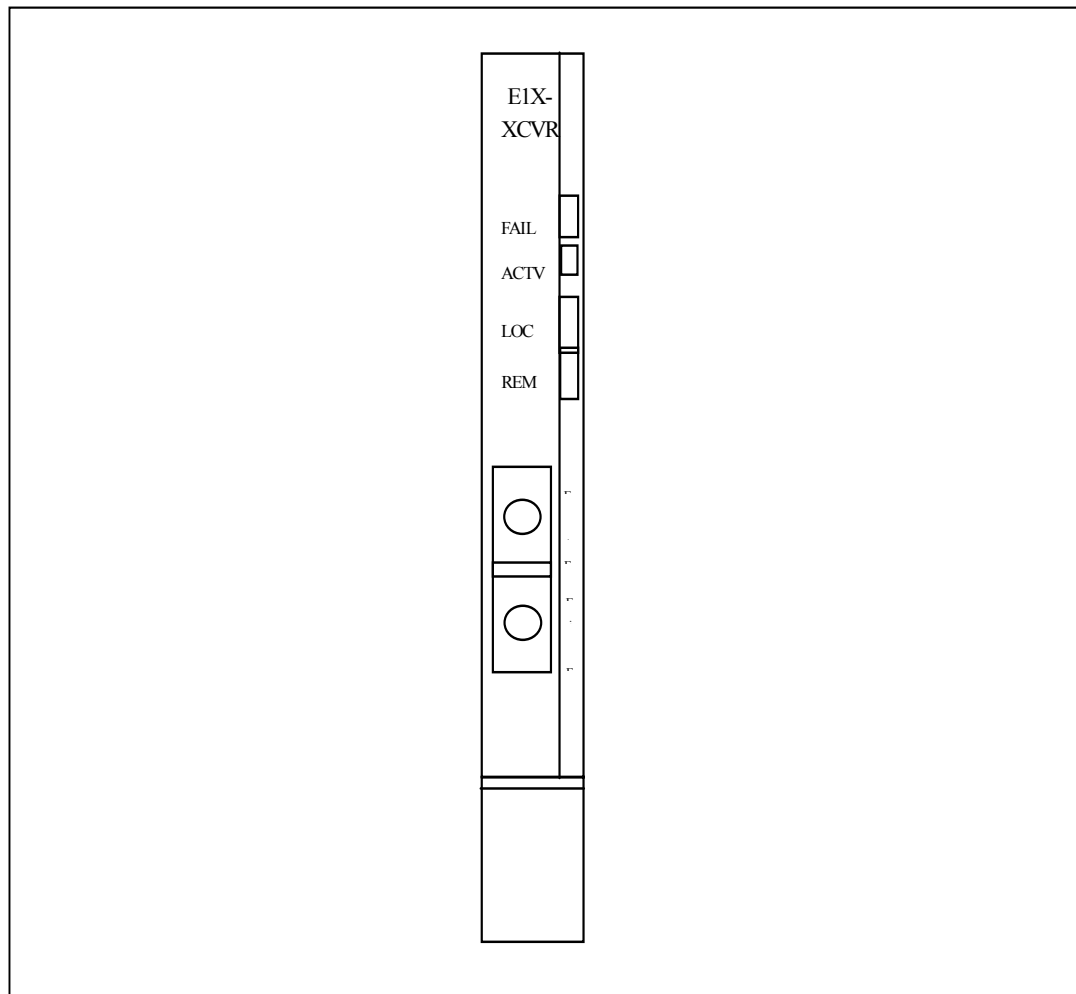

The E1X-XCVR Transceiver performs signaling conversion and data link termination. Line coding is HDB3. The transceiver has selectable alarm thresholds, BER calculation, performance monitoring statistics, and alarm history.

The E1X-XCVR may also be used as a service card, to drop off a single channelized E1 circuit to a customer's G.703 equipment.

There are four LED indicators on the E1X-XCVR Transceiver front panel. A green ACTV LED indicates the unit is busy and must not be unplugged without first removing traffic. A red FAIL LED indicates that the unit has failed. An amber REM LED indicates that the unit is in Far End Alarm, and another amber LOC LED indicates that the unit is in Near END alarm. The transceiver features front panel jack access for testing and monitoring.

Features

- One ITU-T/E1 2.048 Mbps Interface per card
- Double frame, CRC multi-frame formats
- Extensive Loopback Diagnostics
- Front Panel Jack Access for Test and monitoring
- Remote Test Access to Metallic Tip and Ring (In the future)
- Low Power Dissipation
- May be used to deliver fractional E1 to customers or for groomed services

E1X-XCVR Specification	
<u>Signaling Features</u>	
Line Rate	2.048 Mbps ± 50 ppm
Framing	Double frame, CRC multi-frame
Line Coding	HDB3
Channel sequence	CAS or CCS
Error Checking	CRC4
Loopback Modes	Local, Remote
<u>Analog Parameters</u>	
Equalization	Receive Automatic Line Build Out (10 dB attenuation)
	Transmit Fixed 3.0 Vpk±0.3 Vpk
Input Impedance	120Ω(twisted pair)
<u>Environmental</u>	
Operating temperature	-35°C to +60°C
Humidity	up to 98% at 35°C
Max Power Consumption	2.5 W
<u>Dimensions</u>	
	5.125" (13.018 cm) tall (standing up in CBA)
	10.5" (26.67 cm) long (from front of CBA to CBA backplane)
	0.563" (1.429 cm) thick (measured along faceplate - thickest point)
<u>Weight</u>	
	0.5 lbs (0.23 Kilograms)
<u>Compliance</u>	
Jitter	ITU-T G.703 / G.823
Cable Interface	ITU-T G.703
Return Loss	ITU-T G.703
Frame/CRC-4 Multiframe	ITU-T G.704 / G.706
LOF and recovery	ITU-T G.706
LOS	ETSI 300 461-1

4.3.3 Fiber Optic Transceiver (FO-XCVR)

The HTC-1100E Fiber Optic Transceiver interfaces to a single mode Fiber Span, transmitting and receiving the voice or data originating from the channel unit in the subscriber slots of the Local Exchange Terminal (LET) and Remote Subscriber Terminal (RST) as well as E1 metallic transceiver data. The FO-XCVR's transmission rate is 49.152 Mbps. The unit contains both transmitter and receiver on a single card, each connecting to a fiber-optic cable. Its faceplate is shown on this page.

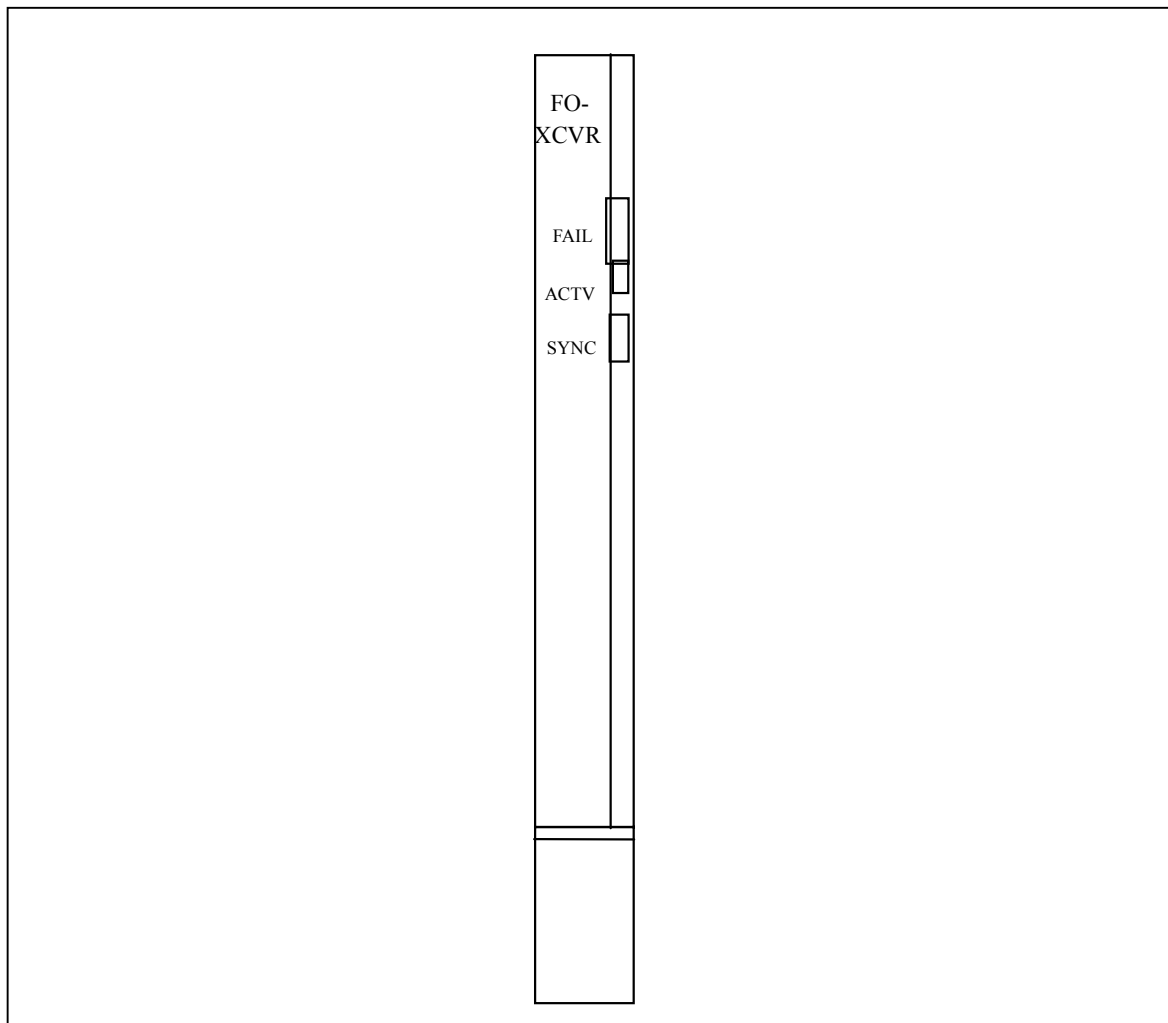

The FO-XCVR uses a single mode fiber with a laser operating at 1310 nm and PINFET receiver to allow non-repeated span lengths of up to 40 kilometers (25 miles). The FO-XCVR may be used on multimode cable with a decreased span length. Single mode "FCPC" connectors are used for their compact size. The FO-XCVR uses compact hybrid micro-electronic circuitry to improve operating reliability.

There are three LED indicators on the Fiber Optic Transceiver front panel. The green ACTV LED indicates that the unit is in service and should not be removed. A red FAIL LED indicates that the unit has failed. A blue SYNC LED provides indication of locked synchronization.

Features

- Single Fiber-Optic Interface per unit
- 1310 nm Single mode laser
- PINFET receiver (-34 dBm sensitivity)
- Capable of transmitting and receiving over fiber span distances of approximately 40 km (25 miles)
- Temperature/age compensated
- μ Processor controlled and monitored
- Link performance monitoring
- Alarm retrieval
- Low Power Dissipation
- Automatic Attenuation (no pads required)

FO-XCVR Specification		
<u>Signaling</u>		
Line Coding	NRZI, Scrambled	
Line Rate	49.152 Mbps	
<u>Transmit Levels</u>		
	-7 □ 1.5 dBm (1,310 nm single longitudinal mode laser)	
<u>Receiver Sensitivity</u>		
Minimum Saturation level	1310 nm	-5.5 dBm
Maximum Sensitivity	1310 nm	-34 dBm
Minimum	Link Loss Budget	25.5 dB
<u>Environmental</u>		
Operating temperature	-35°C to +60°C	
Humidity	up to 98% at 35°C	
Max Power Consumption	9.0 W	
<u>Dimensions</u>		
	5.125" (13.018 cm) tall (standing up in CBA)	
	10.5" (26.67 cm) long (front of CBA to CBA backplane)	
	0.563" (1.429 cm) thick (along faceplate - thickest point)	
<u>Weight</u>		
	0.5 lbs (0.23 Kilograms)	
<u>Compliance</u>		
	ITU-T G.711, G.712m G.713, G.714, G.703, G.823, G.956, G.651, G.652	

4.3.4 Synchronous Digital Hierarchy Transceiver

The Synchronous Digital Hierarchy Transceiver (SDH-XCVR) plug-in card provides 155.52 Mbps optical data interface to a single-mode fiber span. It can transmit and receive voice or data originating from channel units in the LET and RSTs or from other E1 transceivers.

SDH-XCVR supports section and line SDH overhead, but not the path overhead. Install the SDH-XCVR in any of the 22 general-purpose CBA slots at the LET or RST. Deploy the SDH-XCVR in a standalone or common ring configuration to provide added bandwidth over AccessMax network. SDH-XCVR supports FC/PC connector. In a point-to-point configuration, the SDH-XCVR uses two fiber spans. In a ring configuration, the SDH-XCVR uses a single fiber span. (Optional)

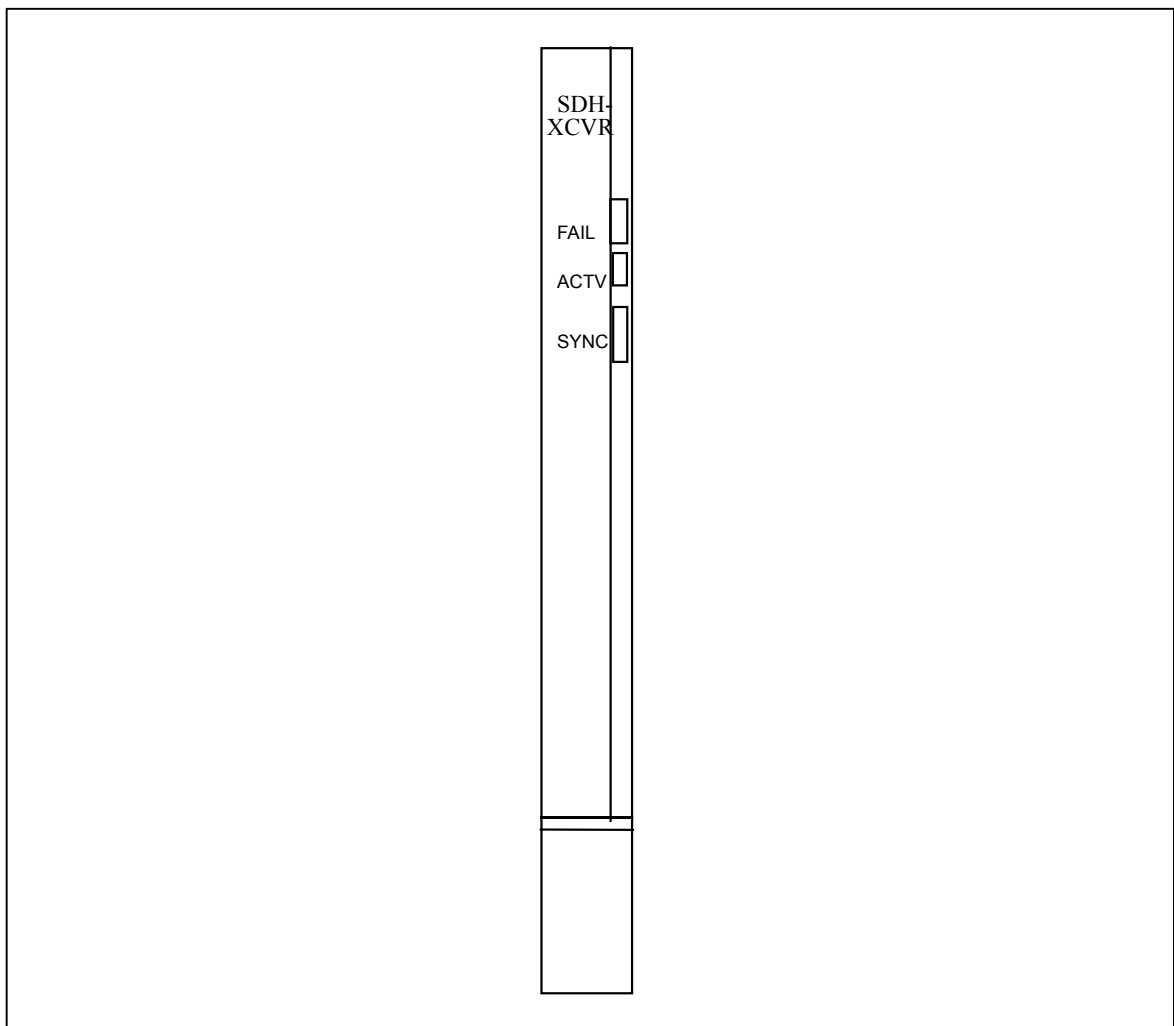

Features

- 1 + 1 optical automation protection switch
- 1310 nm SM (Single Mode) Laser
- ADM, Ring (TBD)
- PIN FET receiver (-34dBm sensitivity)

HTC-1100E System Description

- Transmission range 45 Km
- Micro-processor controlled and monitored
- Optical link performance monitoring
- Provide BER statistics and diagnosis
- History alarm retrieval
- Lower Consumption

SDH-XCVR Specification	
<u>Signaling</u>	
Line Coding	Scrambled
Line Rate	155.52 Mbps
<u>Transmit Levels</u>	
	-7 □ 1.5 dBm (1,310 nm single longitudinal mode laser)
Laser	1310nm (single mode)
Typical output power	-0dBm ±1.0dB
Peak wavelength	1261-1310nm
Spectral width (RMS)	max 7.7nm
Extinction ratio	min 10dB
Output signal jitter	max 0.01 UI rms
<u>Receiver Sensitivity</u>	
Operating wavelength	1260-1310nm
Minimum link loss budget	17.0dBm
Maximum Sensitivity	-28dBm
Minimum overload	-8.0dBm
Optical path penalty	1.0dB/km
Output clock jitter	max 0.01UI rms
Jitter bandwidth	max 130 kHz
Max jitter amplification	max 0.1dB
<u>Environmental</u>	
Operating temperature	-35°C to +60°C
Humidity	up to 98% at 35°C
Max Power Consumption	7.0 W
<u>Dimensions</u>	
	5.125" (13.018 cm) tall (standing up in CBA)
	10.5" (26.67 cm) long (front of CBA to CBA backplane)
	0.563" (1.429 cm) thick (along faceplate - thickest point)
<u>Weight</u>	0.5 lbs (0.23 Kilograms)
<u>Compliance</u>	ITU-T G.957, G.958, G.708, G.711/712/713/714

4.3.5 Medium Range Fiber Optic Transceiver

The HTC-1100E Medium Range Fiber Optic Transceiver interfaces to a single mode Fiber Span, transmitting and receiving the voice or data originating from the channel units in the subscriber slots of the Local Exchange Terminal (LET) and Remote Subscriber Terminal (RST), as well as E1 metallic transceiver data. The FOW-XCVR's transmission rate is 49.152 Mbps. The unit contains both transmitter and receiver on a single card, each connecting to a fiber-optic cable. Its faceplate is shown on this page.

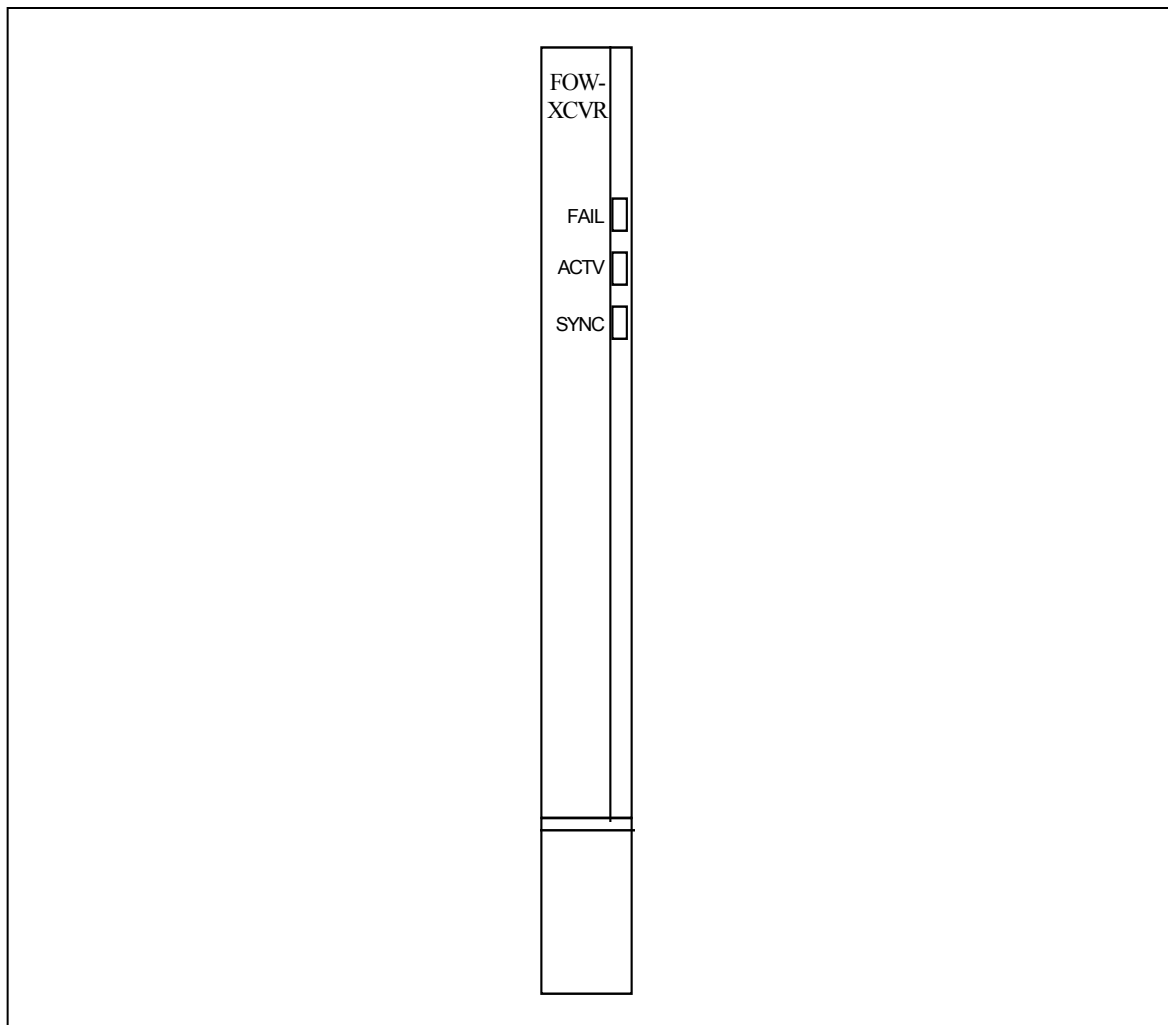

The FOW-XCVR uses a single mod fiber with a laser operating at 1,550 nm and PINFET receiver to allow non-repeated span lengths of approximately 40 miles over single mode fiber optic facilities. Actual distances are dependent upon the dB loss over a span attributable to distance and splices.

The FOW-XCVR has also been designed to work with the FO-XCVR in conjunction with Wavelength Division Multiplexing (WDM) fiber optic couplers. When used in this configuration the HTC-1100E utilizes a single fiber for both transmit and receive paths. This option may be utilized for those applications where fiber conservation is desired.

Single mode "FCPC" connectors are used for their compact size. The FOW-XCVR uses compact hybrid micro-electronic circuitry to improve operating reliability.

There are three LED indicators on the FOW-XCVR front panel, The green ACTV LED indicates that the unit is in service and should not be removed. A red FAIL LED indicates that the unit has failed. A blue SYNC LED provides indication of locked synchronization.

Features

- 50 Mbps fiber optic transmission rate
- 1,550 nm single mode laser
- PIN receiver
- Used for fiber conservation applications in conjunction with an FO-XCVR and a WDM coupler
- Automatic attenuation provided (no pads required)
- Processor controlled and monitored
- Temperature/age compensated
- Alarm retrieval
- Low power dissipation

FOW-XCVR Specification		
<u>Signaling</u>		
Line Coding	NRZI, Scrambled	
Line Rate	49.152 Mbps	
<u>Transmit Levels</u>		
	-7 □ 1.5 dBm (1,550 nm single longitudinal mode laser)	
<u>Receiver Sensitivity</u>		
Minimum Saturation level	1550 nm	-5.5 dBm
Maximum Sensitivity	1550 nm	-34 dBm
Minimum	Link Loss Budget	25.5 dB
<u>Environmental</u>		
Operating temperature	-35°C to +60°C	
Humidity	up to 98% at 35°C	
Max Power Consumption	7.0 W	
<u>Dimensions</u>		
	5.125" (13.018 cm) tall (standing up in CBA)	
	10.5" (26.67 cm) long (front of CBA to CBA backplane)	
	0.563" (1.429 cm) thick (along faceplate - thickest point)	
<u>Weight</u>		
	0.5 lbs (0.23 Kilograms)	
<u>Compliance</u>		
	TR-TSY-000326	

4.3.6 HDSL Transceiver

The HDSL transceiver (HD-XCVR) provides a repeaterless E1 transport method over two pairs of unconditional copper loops up to 4.3 km on 0.5mm wires. All qualifying loops can be used without the removal of bridged taps, binder group separation, etc. It is designed in a full duplex architecture. It transports 1,168 kbps data streams over each twisted pair using 2B1Q line codes. Its faceplate is shown on this page.

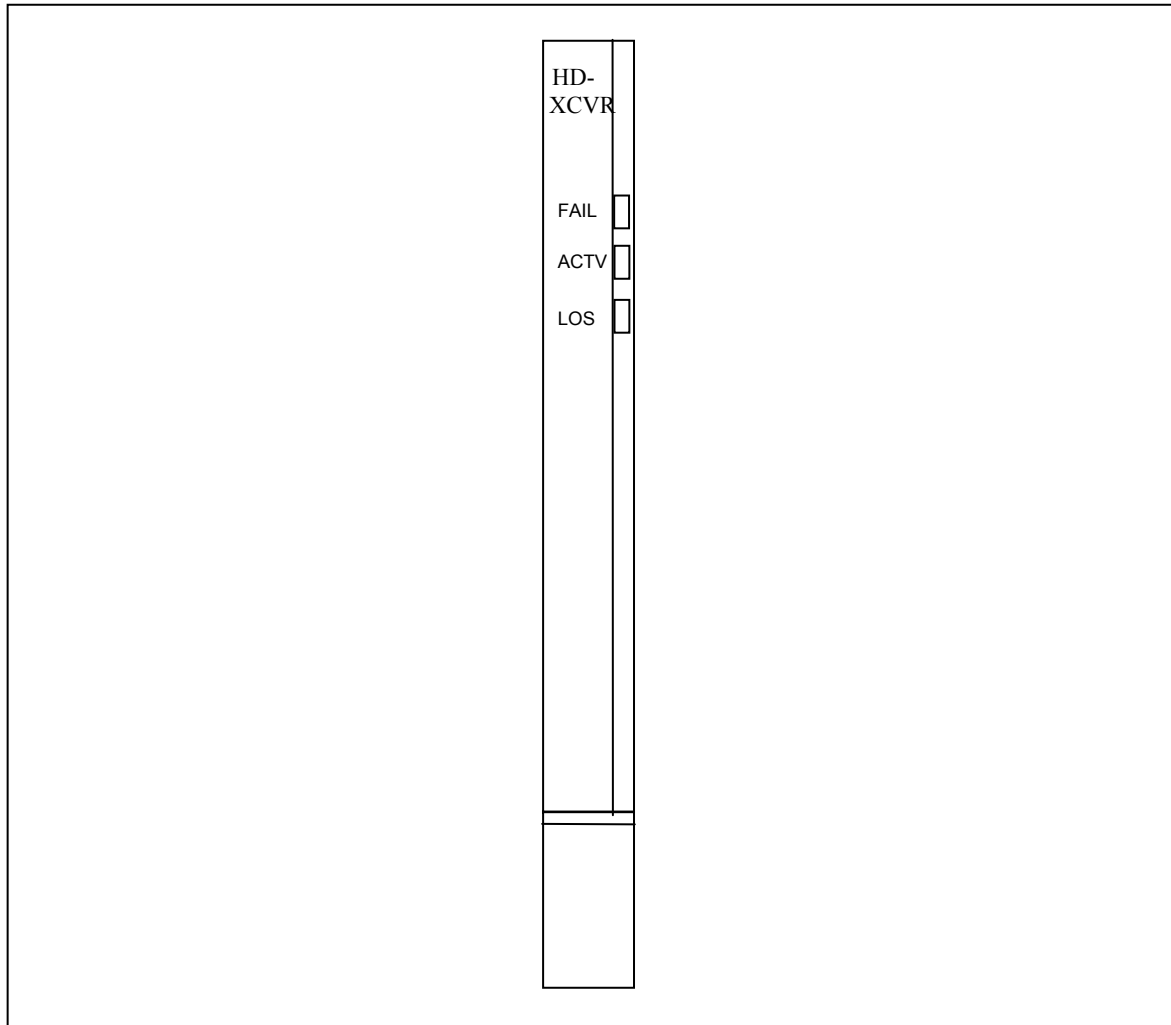

There are three LED indicators on the HD-XCVR front panel. The green ACTV LED indicates that the unit is busy and must not be removed from service. A red FAIL LED indicates that the unit or the system CPU has failed. The red LOS LED indicates the Loop 1 or loop 2 of HDSL has loss of signal or loss of synchronous word.

The HD-XCVR can also be used as channel card in RST and connects to its correspondent DTE, ex HTC-4000 FE/R.

Features

- One HDSL E1 2.048 Mbps Interface per card
- Double frame, CRC multi-frame formats
- Up to 4.3 km non-repeated E1 transmission
- Extensive Loop back Diagnostics

HD-XCVR Specification

Signaling Features

Framing	ETSI ETR 152
BER	< 10 ⁻⁹ at Maximum Loop
Loopback Modes	Local, Remote
Modulation	2B 1Q
Transmission	2Pairs Full Duplex

Loop Parameters

Transmit	13.5 dBm (±0.5dBm)
Output Impedance	135 Ω
Return Loss	>20dB (40kHz to 200 kHz)

Environmental

Operating temperature	-35°C to +60°C
Humidity	up to 98% at 35°C
Average Power Consumption	5 W

Dimensions

5.125" (13.018 cm) tall (standing up in CBA)
 10.5" (26.67 cm) long (front of CBA to CBA backplane)
 0.563" (1.429 cm) thick (along faceplate - thickest point)

Weight

0.5 lbs (0.25 Kilograms)

4.4 Channel Units

4.4.1 Local Exchange International POTS Channel Unit

The HTC-1100E International POTS Channel Unit (LI-POTS) provides six trunk terminating loop start "Plain Old Telephone Service" circuits.

The LI-POTS unit provides loop start only signaling with ring cadence following between ring bursts, and forward disconnect. The caller ID conforms to all FSK and DTMF-based systems. Detection of dial pulses, flash-hooks, and the BT (British Telecom) CLIP wetting pulse.

The LI-POTS unit also provides a universal ringing detector. Its faceplate is shown on this page.

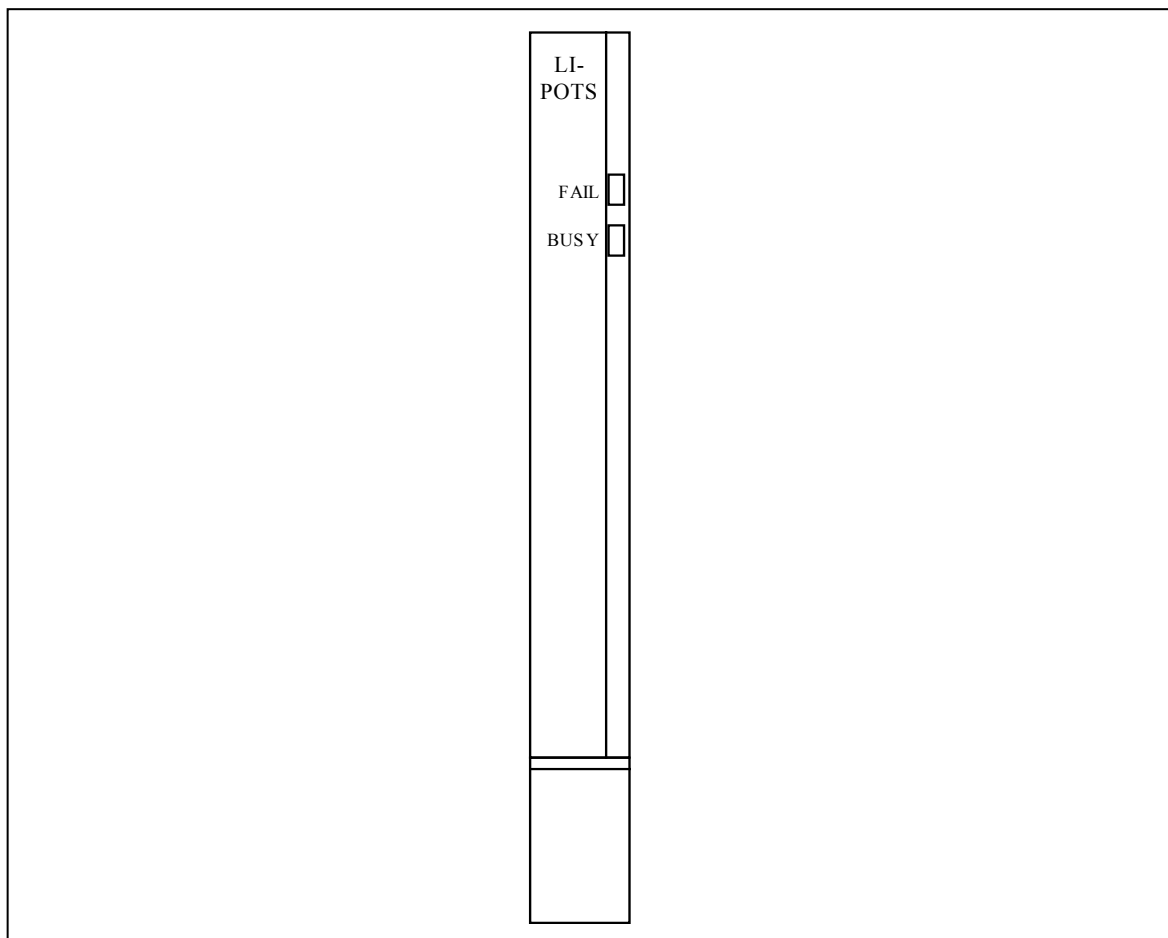

The LI-POTS card is ordinarily equipped in the Local Exchange Terminal (LET); its counterpart, the RI-POTS card, is usually equipped in the Remote Subscriber Terminal (RST). The cards have been environmentally hardened to accommodate special applications, when the LI-POTS card may be located at the RST.

A green BUSY LED indicator, when lit, indicates that the corresponding RI-POTS circuit is busy or is being tested. A red FAIL LED indicates that the unit has failed.

Features

HTC-1100E System Description

- Six Two-Wire POTS Circuits per Card
- Forward Disconnect
- 600Ω or 900Ω Local Exchange Impedance
- Transient Protection for Outdoor Bridging
- Support DTMF and DP signalling
- Low Power Dissipation

LI-POTS Specification

Signaling

End to end signaling delay (normal and reverse battery)	< 40 msec
Pulse distortion (pw > 25 msec)	< 5 msec
Ring detection	< 150 msec
AC ringing load (20 Hz)	4 kΩ +/- 10%
Ring detector Sensitivity	20 Vrms 20-55 Hz
Nominal DC input resistance	430Ω
Nominal open interval detector threshold	10 mA ± 3 mA
Maximum CO wiring resistance	500Ω

Audio

Componding	A Law
Nominal VF input impedance	600Ω or 900Ω
Nominal Net loss (referenced 2 wire 900)	0 dBm +/- 0.4 dB off-hook
Maximum VF overload level	+5 dBm
Frequency response (single ended)	+0.4, -0.5 dBm (300 Hz-3.4 KHz)
Longitudinal Balance > 70 dB (400 Hz -3.4 KHz)	
4-Wire Hybrid Balance(600Ω on 2-Wire)Single Ended > 18 dB	
2-Wire Return loss (600Ω on 2-Wire)Single Ended	> 20 dB
Hybrid Balance	Optimized 600/900

Environmental

Operating temperature	-35°C to +60°C
Humidity	Up to 98% at 35°C
Average Power Consumption	1.0 W

Dimensions

5.125" (13.018 cm) tall (standing up in CBA)
 10.5" (26.67 cm) long (from front of CBA to CBA backplane)
 0.563" (1.429 cm) thick (measured along faceplate - thickest point)

Weight

0.5 lbs (0.23 Kilograms)

Compliance

ITU-T G.711, G.712, G.713, G.714

4.4.2 Remote Subscriber International POTS Channel Unit

The HTC-1100E RI-POTS Channel Unit is the Remote Subscriber Terminal (RST) loop start counterpart to the loop terminating LI-POTS Channel Unit. It provides six circuits of standard loop start "Plain Old Telephone Service."

HTC-1100E RI-POTS cards provide ring cadence following, local ring trip, mission between ring-bursts and forward disconnect. Its faceplate is shown on this page.

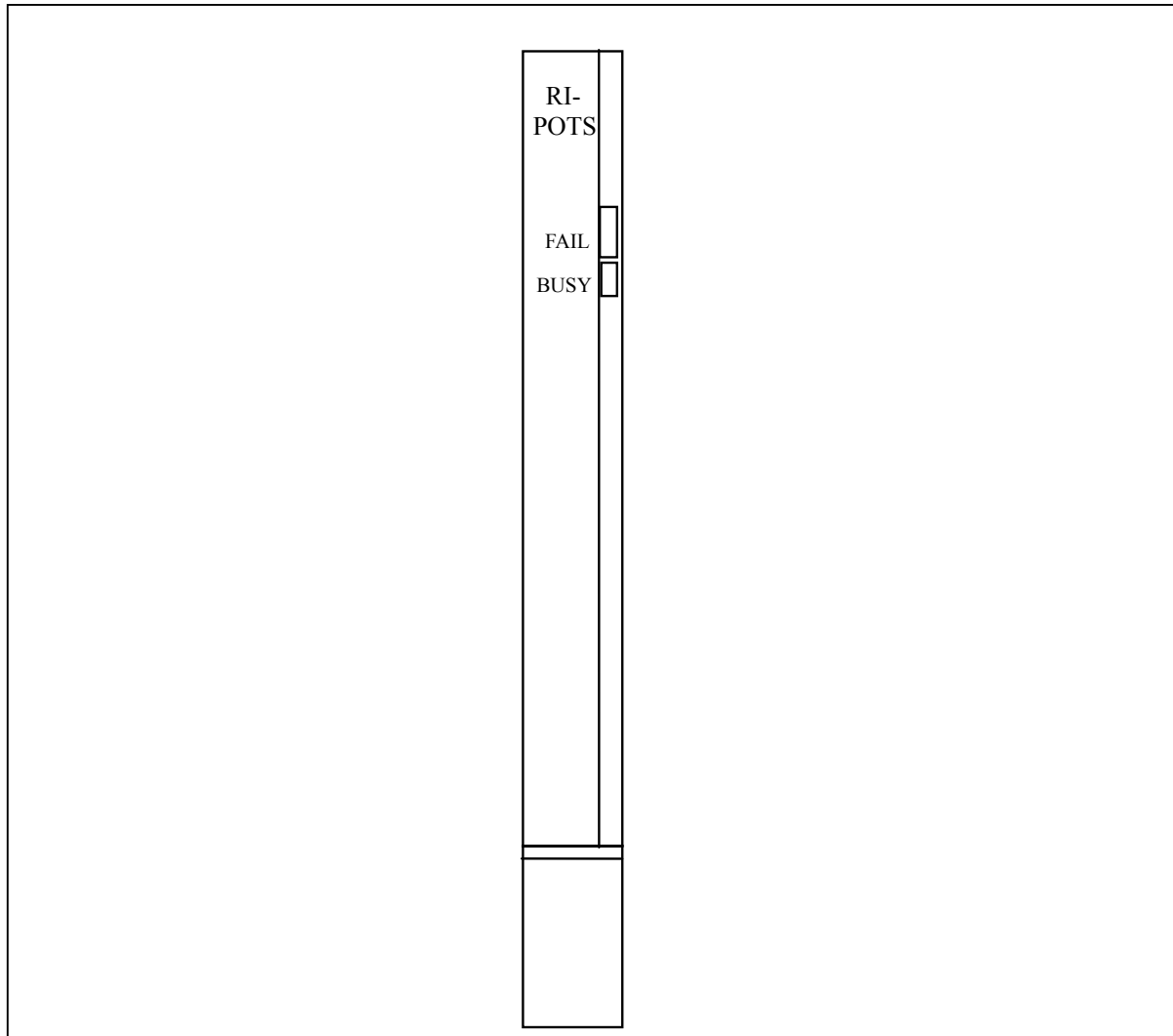

The RI-POTS card is ordinarily equipped in the RST, its counterpart, the LI-POTS card, is usually equipped in the Local Exchange Terminal (LET).

A green BUSY LED indicator, when lit, indicates that the RI-POTS circuit is busy or is being tested and should not be removed from service. A red FAIL LED indicates that the unit has failed. The RI-POTS features backplane metallic tip-ring access to enable testing using the Metallic Test Unit.

Features

- Six Two-Wire POTS Circuits per Card
- Forward Disconnect
- 600 Ω or 900 Ω Terminating Impedance
- Transient Protection
- Remote Test Access to Metallic Tip and Ring
- Support DTMF and DP signalling
- Low Power Dissipation

4.4.3 Local Exchange International Advanced POTS Channel Unit

The HTC-1100E International Advanced POTS Channel Unit (LI-APOTS) provides six trunk terminating loop start "Plain Old Telephone Service" circuits like the LI-POTS.

HTC-1100E LI-APOTS provides two capabilities not supported on the LI-POTS. These are battery reversal and pulse metering which are used for special POTS applications.

Loop start signaling with ring cadence following, on-hook transmission between ring bursts and forward disconnect are also provided.

The LI-APOTS unit also provides a high onhook DC resistance as well as a universal ringing detector. Its faceplate is shown on this page.

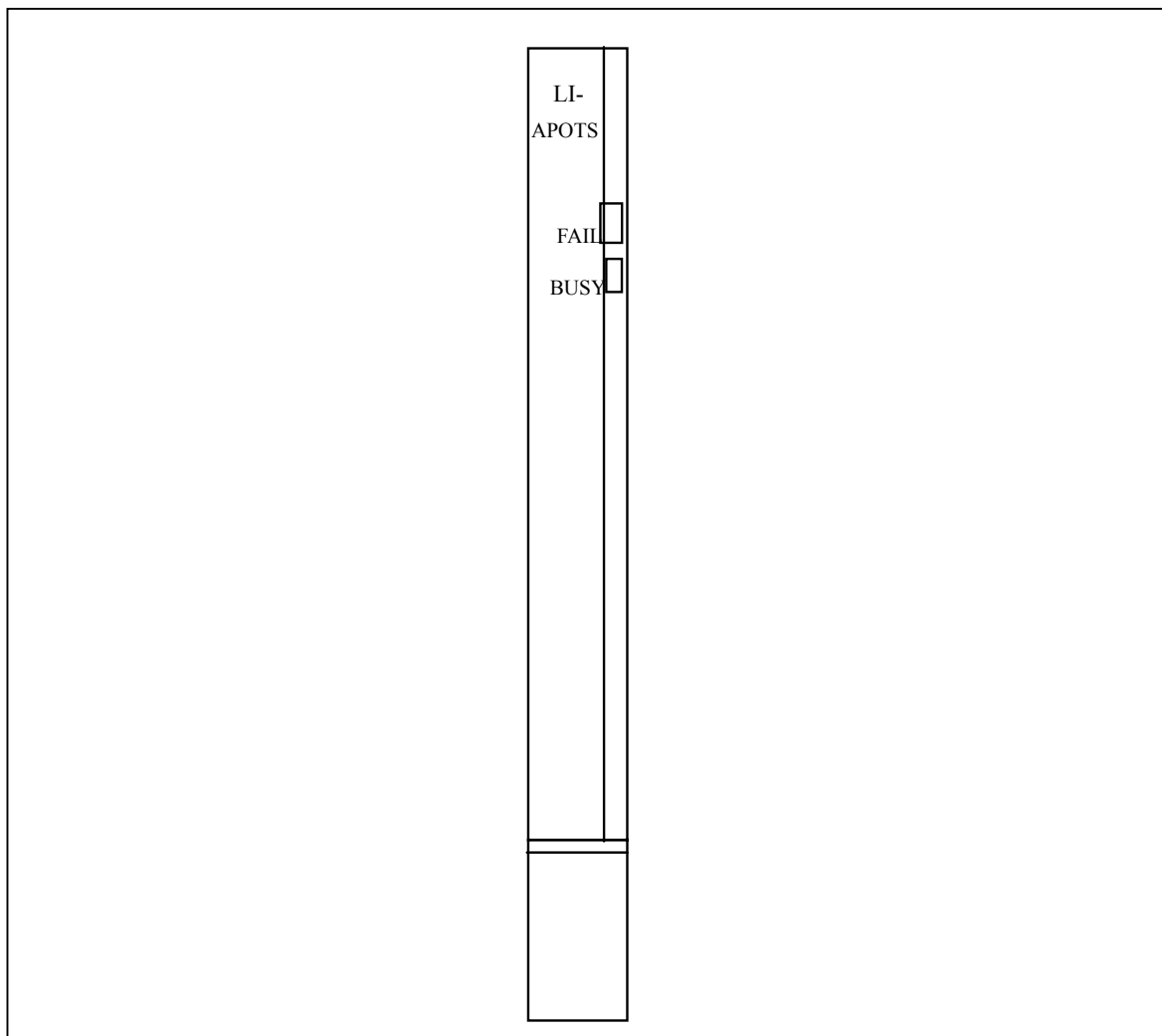

The LI-APOTS card is ordinarily equipped in the Local Exchange Terminal (LET); its counterpart, the RI-APOTS card, is usually equipped in the Remote Subscriber Terminal (RST). The cards have been environmentally hardened to accommodate special applications, when the LI-APOTS card may be located at the RST.

A green BUSY LED indicator, when lit, indicates that the corresponding RI-APOTS circuit is busy or

is being tested. A red FAIL LED indicates that the unit has failed.

Features

- Six Two-Wire POTS Circuits per Card
- Forward Disconnect
- Battery Reversal
- Pulse Metering
- 600Ω or 900Ω Local Exchange Impedance
- Transient Protection for Outdoor Bridging
- Support DTMF and DP signalling
- Low Power Dissipation

LI-APOTS Specification

Signaling

End to end signaling delay (normal and reverse battery)	< 40 msec
Pulse distortion (pw > 25 msec)	< 5 msec
Ring detection	< 150 msec
Meter pulse detection frequencies	12 KHz, 16 KHz±1%
Meter pulse amplitude	50 mV - 5 V
AC ringing load (20 Hz)	4 kΩ+/- 10%
Ring detector Sensitivity	20 Vrms 20-55 Hz
Nominal DC input resistance	430Ω
Nominal open interval detector threshold	10 mA ± 3 mA
Maximum CO wiring resistance	500Ω
Battery Reversal delay	< 40 msec

Audio

Companding	A Law
Nominal VF input impedance	600Ω or 900Ω
Nominal Net loss (referenced 2 wire 900)	0 dBm +/- 0.4 dB
Maximum VF overload level	+5 dBm
Frequency response (single ended)	300 Hz-3.4 KHz + 0.4, -0.5 dBm
Longitudinal Balance	400 Hz -3.4 KHz > 70 dB
4-Wire Hybrid Balance(600Ω on 2-Wire)Single Ended	> 18 dB
2-Wire Return loss (600Ω on 2-Wire)Single Ended	> 20 dB
Hybrid Balance	Optimized 600/900

Environmental

Operating temperature	-35°C to +60°C
Humidity	Up to 98% at 35°C
Average Power Consumption	1.0 W

Dimensions

5.125" (13.018 cm) tall (standing up in CBA)
 10.5" (26.67 cm) long (from front of CBA to CBA backplane)
 0.563" (1.429 cm) thick (measured along faceplate - thickest point)

Weight

0.5 lbs (0.23 Kilograms)

Compliance

ITU-T G.713, G.714

4.4.4 Remote Subscriber International Advanced POTS Channel Unit

The HTC-1100E RI-APOTS Channel Unit is the Remote Subscriber Terminal (RST) loop start counterpart to the loop terminating LI-APOTS Channel Unit. It provides six circuits of standard loop start "Plain Old Telephone Service" with pulse metering and battery reversal.

HTC-1100E RI-APOTS cards provide ring cadence following, local ring trip and forward disconnect. Its faceplate is shown on this page.

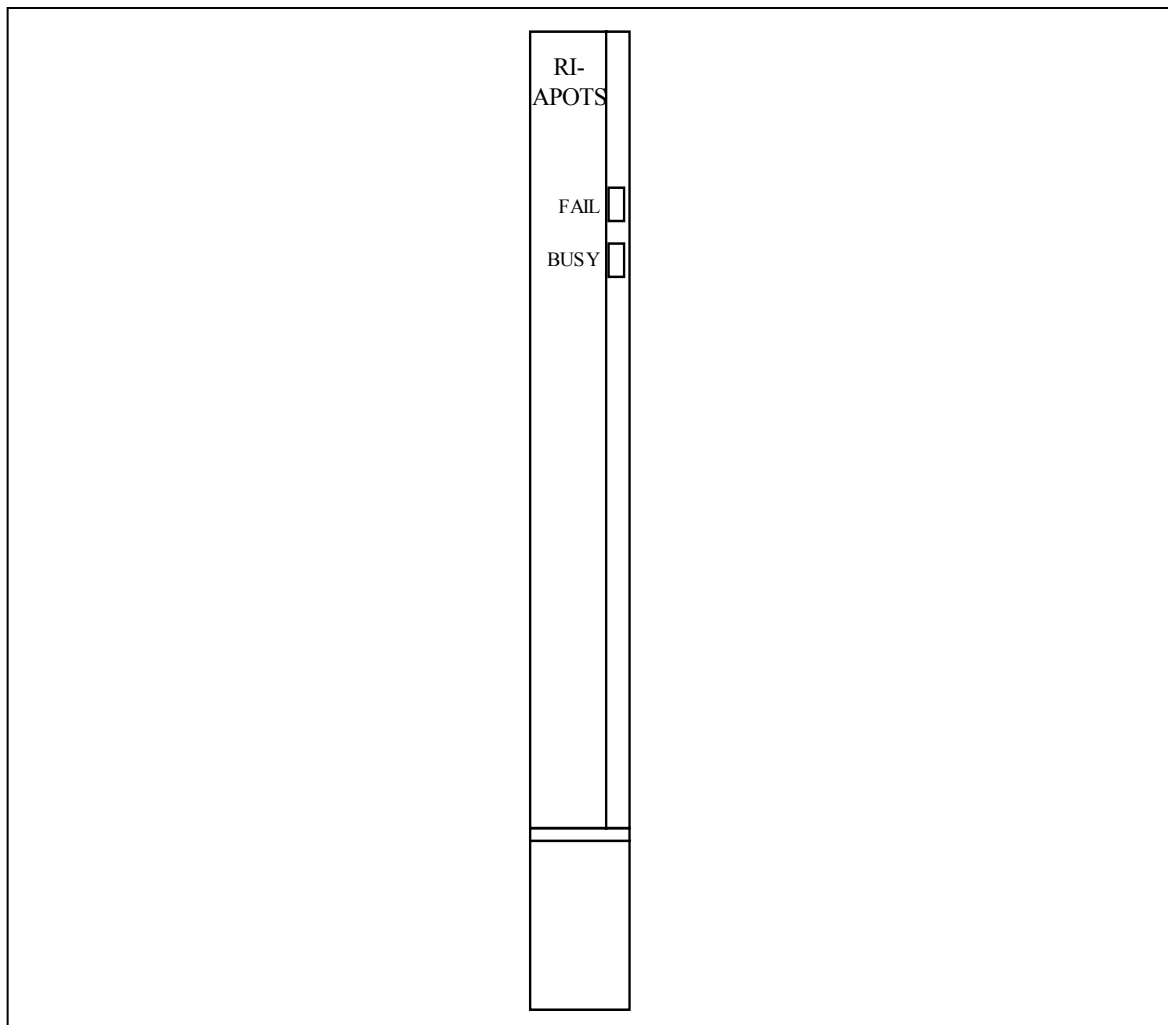

The RI-APOTS card is ordinarily equipped in the RST, its counterpart, the LI-POTS card, is usually equipped in the Local Exchange Terminal (LET).

A green BUSY LED indicator, when lit, indicates that the RI-APOTS circuit is busy or is being tested and should not be removed from service. A red FAIL LED indicates that the unit has failed. The RI-APOTS features backplane metallic tip-ring access to enable testing using the Metallic Test Unit.

Features

- Six Two-Wire POTS Circuits per Card
- Pulse Metering
- Battery Reversal
- 600Ω or 900Ω Terminating Impedance
- Forward Disconnect
- Transient Protection
- Remote Test Access to Metallic Tip and Ring
- Support DTMF and DP signalling
- Low Power Dissipation

RI-APOTS Specification	
<u>Signaling</u>	
End to End signaling delay (normal and reverse)	< 40 msec
Pulse distortion (pw > 25 msec)	< 15 msec
Meter pulse generator	12 kHz, 16 KHz±1%
Meter pulse output level	1.1 Vrms @ 1200Ω
Ring Trip Detection (85 Vrms, 20 Hz)	> 2000Ω
Ring Trip Delay (85 Vrms, 20 Hz)	< 40 msec
Maximum Loop Length	1800Ω@ 25 mA
Open Ckt. Voltage - Normal Mode (Batt.-52 V)	50 V
Open Ckt. Voltage - On Hook Transmission Mode	44 V +/- 0.5V
Off-Hook Detection Threshold	< 2.0kΩ
On-Hook Detection Threshold	> 9 kΩ
Battery Reversal Delay	< 40 msec
<u>Audio</u>	
Companding	A Law
Nominal Input Impedance	600Ωor 900Ω
Nominal Loss (Referenced 2 wire 900Ω)	-2.0 dBm +/- 0.5 dB
Maximum VF Overload level	+5 dBm
Return Loss Single Ended	> 20 dB (300 Hz - 3.4 KHz)
Longitudinal Balance	> 50 dB (300 Hz - 3.4 KHz)
<u>Environmental</u>	
Operating temperature	-35°C to +60°C
Humidity	up to 98% at 35°C
Average Power Consumption	2.0 W
<u>Dimensions</u>	
	5.125" (13.018 cm) tall (standing up in CBA)
	10.5" (26.67 cm) long (from front of CBA to CBA backplane)
	0.563" (1.429 cm) thick (measured along faceplate - thickest point)
<u>Weight</u>	
	0.5 lbs (0.23 Kilograms)
<u>Compliance</u>	
	ITU-T G.713, G.714

4.4.5 E&M Channel Unit (E&M)

The E&M Channel Unit is one of HTC-1100E's Special Services channel units. It provides two subscriber line circuits configured for operation in E&M Modes I or V, and one subscriber line circuit for E&M Modes II, III and IV.

The E&M channel unit also supports DX signaling. It can be used to provide subscriber line circuits for Tandem Types I and II and PLR (pulse Link Repeater) Types I and II. In addition, it may be used in a transmission only mode. The E&M channel unit can provide either two or four wire or TO (Transmission Only) mode service. The option of 2 wire or 4 wire or TO mode can be set by user in CIT menu. Its faceplate is shown on this page.

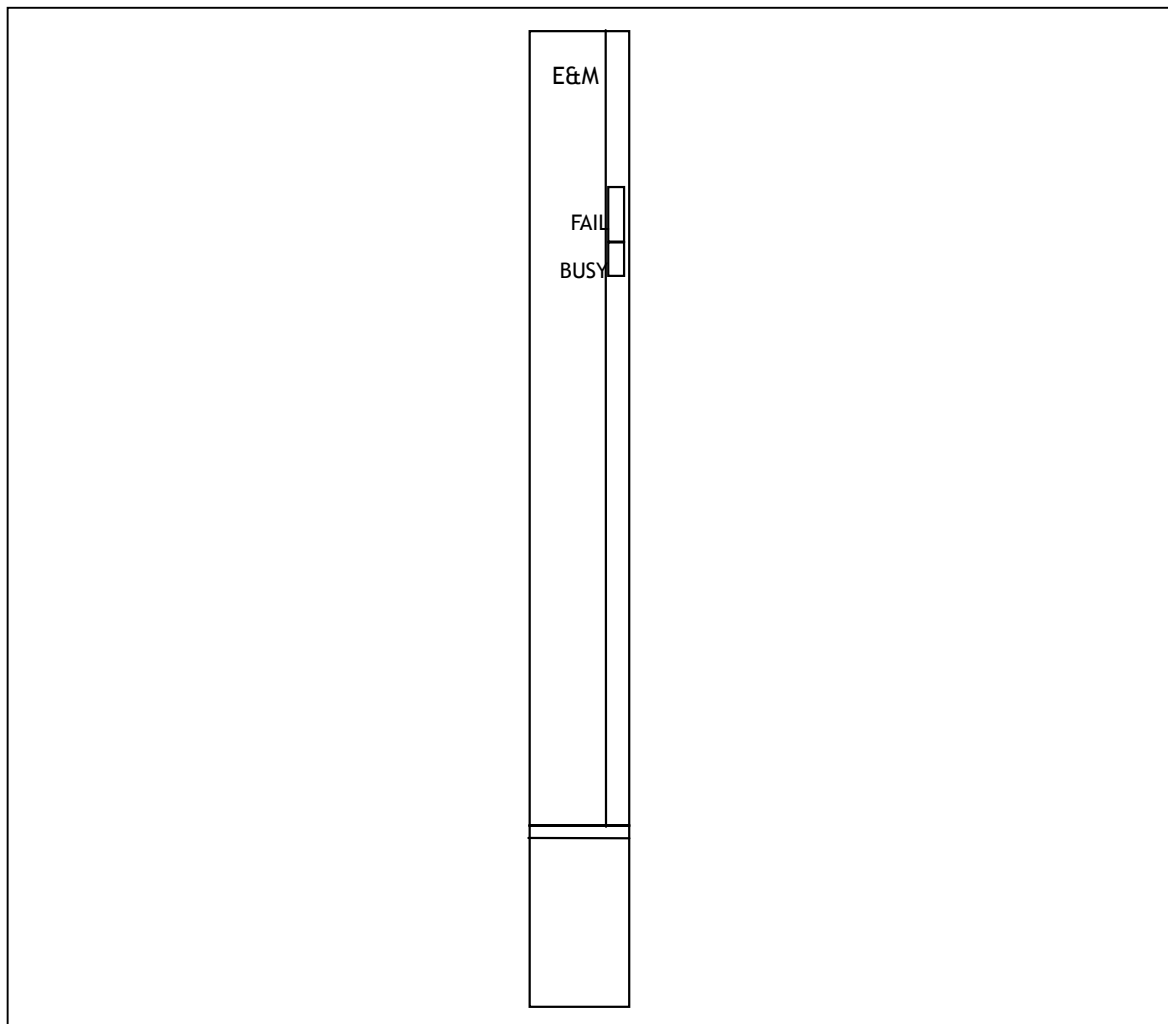

The E&M channel unit has a fixed impedance of 600 ohms. Voice frequency gain is provisionable in 0.1 dB increments within a 23 dB range.

When the E&M Card used CAS signalling mode, The a,b,c,d bits should be setting "1","1","0","1" when there are not be used. At Mode V, the communication defined between E wire and M wire as below : (assume A and B are located at the opposite site)

Signalling Direction		User A status		User B status	
A to B	B to A	M wire	E wire	M wire	E wire
On-hook	On-hook	Open	Open	Open	Open
Off-hook	On-hook	Short	Open	Open	Short
On-hook	Off-hook	Open	Short	Short	Open
Off-hook	Off-hook	Short	Short	Short	Short

There are two LED indicators on the E&M front panel. The green BUSY LED indicates that the E&M Channel Unit is busy or is being tested and should not be removed from service. A red LED indicates that the unit has failed.

Access to the line circuits is provided on the backplane to enable testing with the Metallic Test Unit.

Features

- provides E&M circuits -- one or two circuits per card depending on Mode
- Tandem, PLR signaling, and DX Signaling (software provisionable)
- Provisionable transmit and Receive Gain
- 2 Wire : Tx Gain Range : -4 ~ +5
- Rx Gain Range : 0 ~ -10
- 4 Wire : Tx Gain Range : -6 ~ +16
- Rx Gain Range : -16 ~ +8
- Remote Test Access to Metallic Tip-Ring Pair
- Low Power Dissipation

E&M Specification	
<u>Signaling</u>	
Signaling Types	E&M type I, II, III, IV and V; Tandem Type I and II; PLR types I and II; DX
Signaling Delay	40 ms Maximum
Wink Distortion for any off wink > 50 msec	±10 msec
On-Hook Interval Distortion for any On-Hook Interval > 50 msec	±22 msec
Maximum Loop Length	300Ω
Pulse Distortion	> 3% at 12 pps (30% to 90% break)
<u>Audio</u>	
Nominal Transmission Level	
- Transmit	-17.5 to +7.0 dBm
- Receive	-16.0 to +8.5 dBm
Line Impedance	600Ω
Return Loss, 300 - 3000 Hz	> 20 dB
Longitudinal Balance 74 dB @ 1000 Hz	
Idle Channel Noise	< -65 dBm0p
<u>Environmental</u>	
Operating temperature	-35°C to +60°C
Humidity	up to 98% at 35°C
Average Power Consumption	3.0 W
<u>Dimensions</u>	
	5.125" (13.018 cm) tall (standing up in CBA)
	10.5" (26.67 cm) long (from front of CBA to CBA backplane)
	0.563" (1.429 cm) thick (measured along faceplate - thickest point)
<u>Weight</u>	
	0.5 lbs (0.23 Kilograms)
<u>Compliance</u>	
	ITU-T G.712, G.713, G.714

4.4.6 Local Exchange International POTS Channel Unit

The HTC-1100E International POTS Channel Unit (LI-EPOTS) provides six trunk terminating loop start "Plain Old Telephone Service" circuits.

The LI-EPOTS unit provides loop start only signaling with ring cadence following, on-hook transmission between ring bursts (for caller ID), and forward disconnect. The caller ID conforms to all FSK and DTMF-based systems. Detection of dial pulses, flash-hooks, and the BT (British Telecom) CLIP wetting pulse.

The LI-EPOTS unit also provides a high on-hook DC resistance as well as a universal ringing detector. Its faceplate is shown on this page.

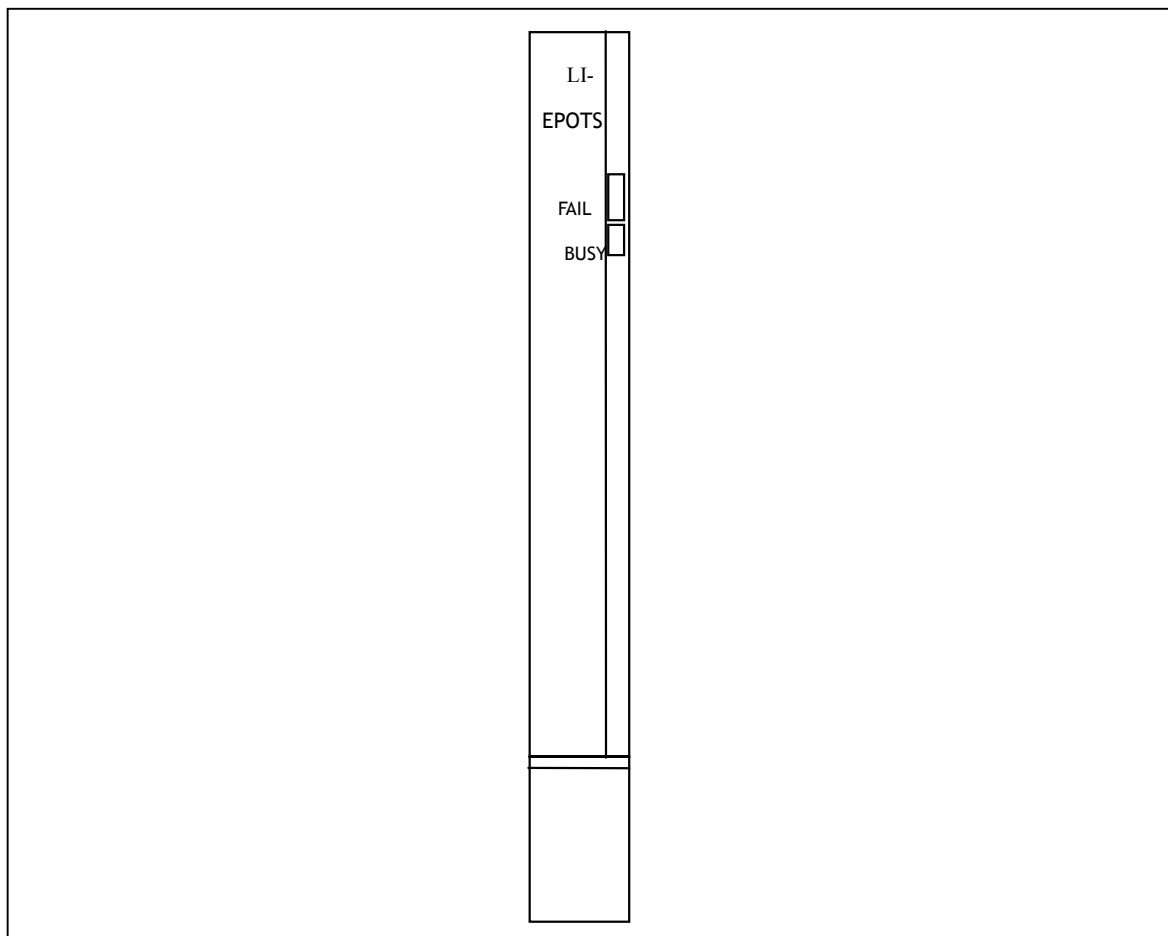

The LI-EPOTS card is ordinarily equipped in the Local Exchange Terminal (LET); its counterpart, the RI-EPOTS card, is usually equipped in the Remote Subscriber Terminal (RST). The cards have been environmentally hardened to accommodate special applications, when the LI-EPOTS card may be located at the RST.

A green BUSY LED indicator, when lit, indicates that the corresponding RI-EPOTS circuit is busy or is being tested. A red FAIL LED indicates that the unit has failed.

Features

- Six Two-Wire POTS Circuits per Card

HTC-1100E System Description

- Forward Disconnect
- 600Ω or 900Ω Local Exchange Impedance
- Transient Protection for Outdoor Bridging
- Support DTMF and DP signalling
- Low Power Dissipation
- On-hook transmission for Caller's ID
- Compatible with British Telecom (BT) SIN227 & SIN242
- Compatible with Bellcore TR-NWT-000030 & SR-TSV-002476
- 1200 baud BELL 202 and CCITT V.23 Frequency Shift Keying (FSK)
- BT Calling Line Identity Presentation (CLIP)
- CTA CLIP
- Bellcore Calling Identity Delivery (CID) systems

LI-EPOTS Specification

Signaling

End to end signaling delay (normal and reverse battery)	< 40 msec
Pulse distortion (pw > 25 msec)	< 5 msec
Ring detection	< 150 msec
AC ringing load (20 Hz)	4 kΩ +/- 10%
Ring detector Sensitivity	20 Vrms 20-55 Hz
Nominal DC input resistance	430Ω
Nominal open interval detector threshold	10 mA ± 3 mA
Maximum CO wiring resistance	500Ω

Audio

Compadding	A Law
Nominal VF input impedance	600Ω or 900Ω
Nominal Net loss (referenced 2 wire 900)	0 dBm +/- 0.4 dB off-hook
Maximum VF overload level	+5 dBm
Frequency response (single ended)	+0.4, -0.5 dBm (300 Hz-3.4 KHz)
Longitudinal Balance > 70 dB (400 Hz -3.4 KHz)	
4-Wire Hybrid Balance(600Ω on 2-Wire)Single Ended > 18 dB	
2-Wire Return loss (600Ω on 2-Wire)Single Ended	> 20 dB
Hybrid Balance	Optimized 600/900

Environmental

Operating temperature	-35°C to +60°C
Humidity	up to 98% at 35°C
Average Power Consumption	1.0 W

Dimensions

5.125" (13.018 cm) tall (standing up in CBA)
 10.5" (26.67 cm) long (from front of CBA to CBA backplane)
 0.563" (1.429 cm) thick (measured along faceplate - thickest point)

Weight

0.5 lbs (0.23 Kilograms)

Compliance

ITU-T G.713, G.714

4.4.7 Remote Subscriber International Enhanced POTS Channel Unit

The HTC-1100E RI-EPOTS Channel Unit is the Remote Subscriber Terminal (RST) loop start counterpart to the loop terminating LI-EPOTS Channel Unit. The RI-EPOTS Channel Unit may be used in place of the RI-EPOTS. It provides six circuits of standard loop start "Plain Old Telephone Service."

HTC-1100E RI-EPOTS cards provide ring cadence following, local ring trip, on-hook transmission between ring-bursts (for caller ID). The caller ID conforms to all FSK and DTMF-based systems. It transfers dial pulses, flash-hooks, and the BT (British Telecom) CLIP wetting pulse to customer premier equipment (CPE). The following shows the faceplate of the RI-EPOTS.

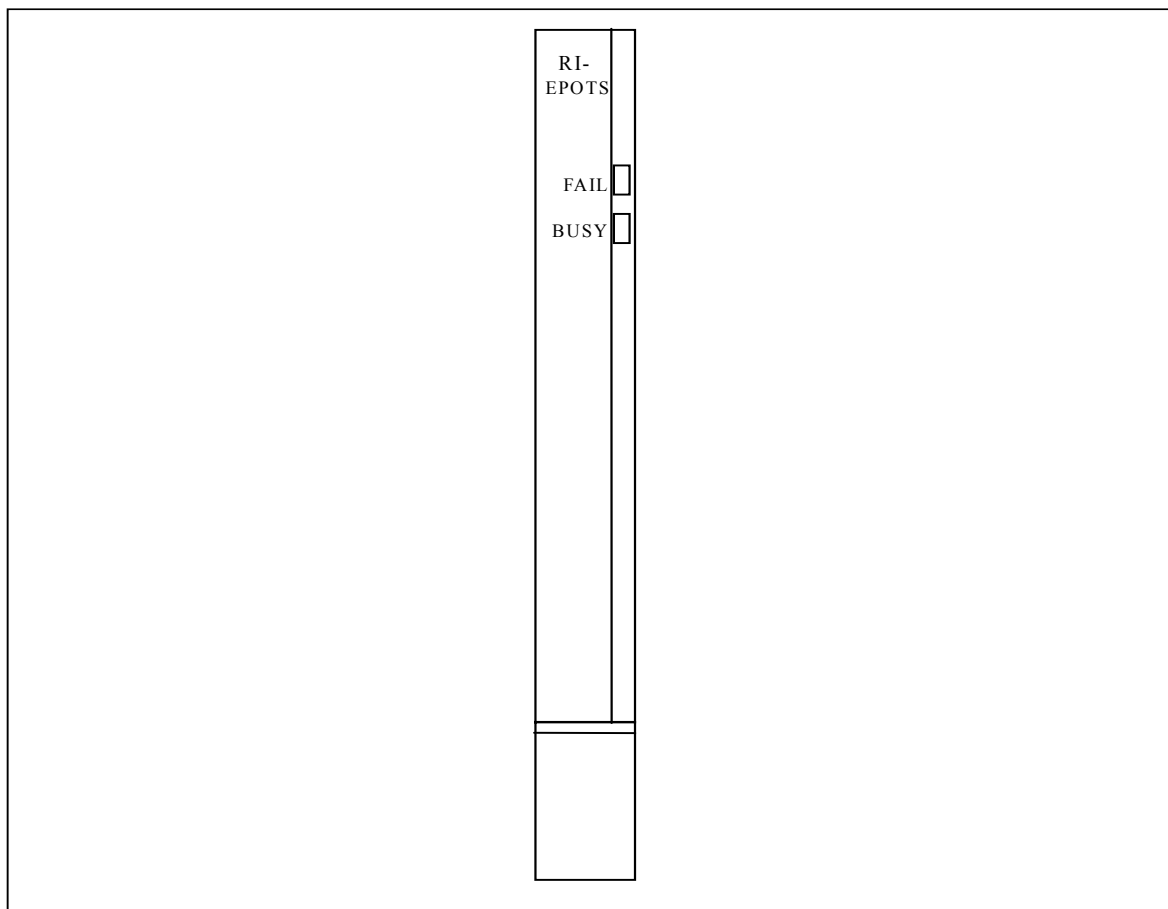

The RI-EPOTS card is ordinarily equipped in the RST, its counterpart, the LI-EPOTS card, is usually equipped in the Local Exchange Terminal (LET).

The RI-EPOTS card has a maximum loop length (including station) of 2000 ohms. it can provide telephone service at long distances from Remote Subscriber Terminal (RST).

A green BUSY LED indicator, when lit, indicates that the RI-EPOTS circuit is busy or is being tested and should not be removed from service. A red FAIL LED indicates that the unit has failed. The RI-EPOTS features backplane metallic tip-ring access to enable testing using the Metallic Test Unit.

Features

- Six Two-Wire POTS Circuits per Card

HTC-1100E System Description

- On-hook transmission (CLASS) capability
- 600Ω or 900Ω Terminating Impedance
- Long Loop Length
- Transient Protection
- Remote Test Access to Metallic Tip and Ring
- Support DTMF and DP signalling
- Low Power Dissipation
- Compatible with British Telecom (BT) SIN227 & SIN242
- Compatible with Bellcore TR-NWT-000030 & SR-TSV-002476
- 1200 baud BELL 202 and CCITT V.23 Frequency Shift Keying (FSK)
- BT Calling Line Identity Presentation (CLIP)
- CTA CLIP
- Bellcore Calling Identity Delivery (CID) systems

RI-EPOTS Specification

Signaling

End to End signaling delay (normal and reverse)	< 40 msec
Pulse distortion (pw > 25 msec)	< 15 msec
Ring Trip Detection (85 Vrms, 20 Hz)	> 2000Ω
Ring Trip Delay (85 Vrms, 20 Hz)	< 40 msec
Maximum Loop Length excluding station	2000Ω@ 25 mA
Open Ckt. Voltage - Normal Mode (Batt.-52 V)	50 V
Open Ckt. Voltage - On Hook Transmission Mode	44 V +/- 0.5V
Off-Hook Detection Threshold	< 2.0kΩ
On-Hook Detection Threshold	> 9 kΩ

Audio

Companding	A Law
Nominal Input Impedance	600Ωor 900Ω
Nominal Loss (Referenced 2 wire 600Ω)	2.0 dB +/- 0.5 dB
Maximum VF Overload level	+5 dBm
Return Loss (single ended)	> 18 dB (300 Hz - 3.4 KHz)
Longitudinal Balance	> 50 dB (300 Hz - 3.4 KHz)

Environmental

Operating temperature	-35°C to +60°C
Humidity	up to 98% at 35°C
Average Power Consumption	2.0 W

Dimensions

- 5.125" (13.018 cm) tall (standing up in CBA)
- 10.5" (26.67 cm) long (from front of CBA to CBA backplane)
- 0.563" (1.429 cm) thick (measured along faceplate - thickest point)

Weight

0.5 lbs (0.23 Kilograms)

Compliance

ITU-T G.713, G.714

4.4.8 Local Exchange Universal Voice Grade Channel Unit

The SLC-E (Subscriber Line Circuit for Exchange) and DPT (Dail Pulse Termination) are special versions of L-UVG(Local Exchange Terminal Universal Voice Grade). They have the same hardware and electrical features. L-UVG is the R-UVG’s counterpart, SLC-E is the SLC-T counterpart, and DPT is the DPO counterpart, L-UVG/SLC-E/DPT are equipped at the Local Exchange Terminal. The L-UVG/SLC-E/DPT cards are direct-mapped to the corresponding R-UVG/SLC-T/DPO, separately. L-UVG/SLC-E/DPT establishes six dedicated circuits, thereby reducing the total number of spans that can be concentrated. The L-UVG/SLC-E/DPT card provides six, 2-wire switched analog circuits that support ground start, loop start, pulse metering, battery reversal signaling for applications such as PBX trunks. The following shows the faceplates of the L-UVG and SLC-E and DPT.

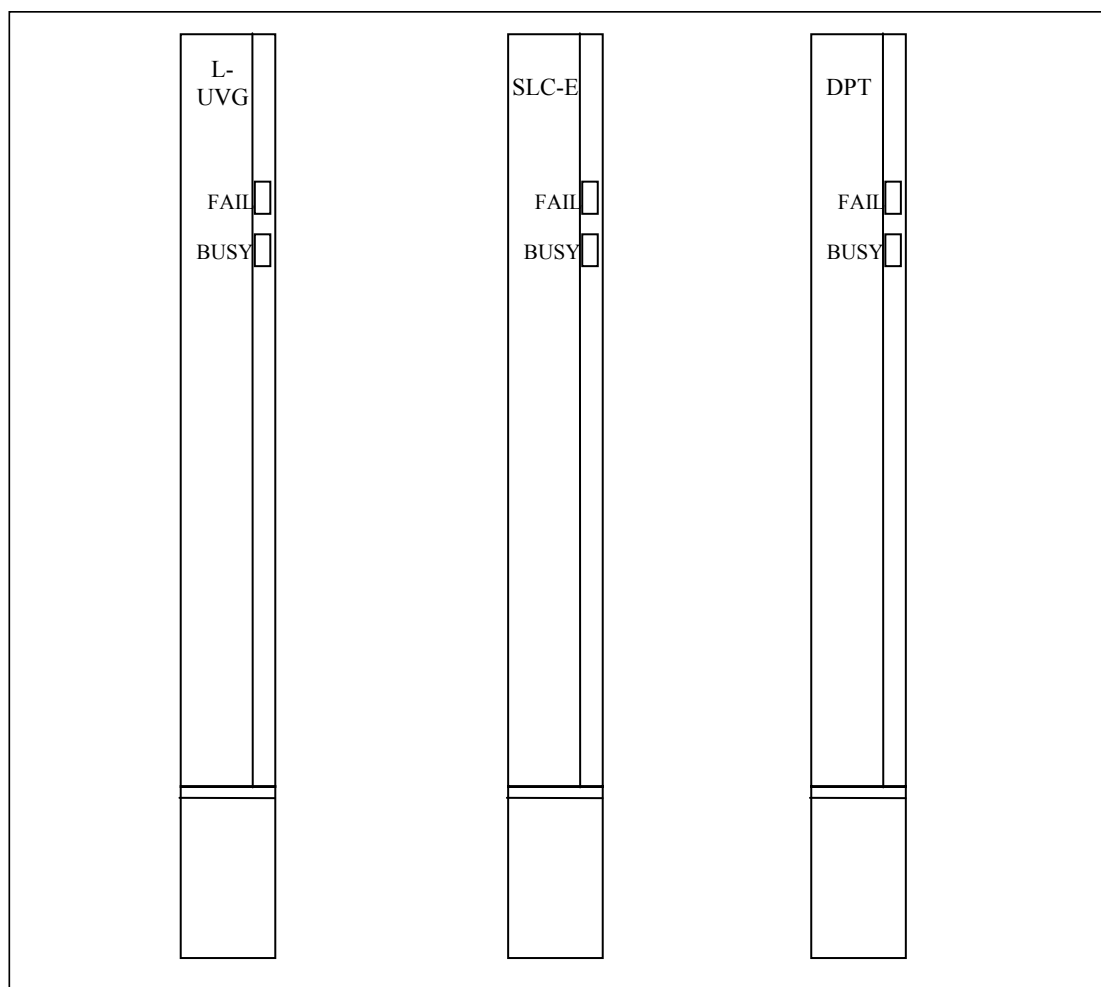

L-UVG/SLC-E/DPT cards provide ring cadence following, including ring-ping, on-hook transmission between ring bursts and forward disconnect. L-UVG/SLC-E/DPT also supports precision gain adjustment in 0.1 dB steps over a 12.0 dB range. L-UVG/SLC-E/DPT may be employed for Direct Inward Dialing (DID) applications. L-UVG/SLC-E/DPT can also be used to provide international coin (payphone) service.

A green BUSY LED indicator, when lit, indicates that the circuit is busy or is being tested and should not be removed from service. A red FAIL LED indicates that the unit has failed.

SLC-E (Subscriber Line Circuit for Exchange) and DPT (Dail Pulse Termination) are designed for

Korea applications. Therefor they can support Korea R2 and Korea D4 signal.

Features

- Six Two-Wire Circuits per Card
- Provisionable gain
- Software selectable transmission gain 0.1dB steps
- Software provisionable 600Ω or 900Ω Terminating Impedance
- Ground start/loop start capability
- Forward disconnect
- Wild ring voltage/frequency detection window
- Pulse metering and battery reversal applications
- On-hook transmission capability
- SLC-E and DPT can support Korea R2 and Korea D4 signal
- Support DTMF and DP signalling

L-UVG /SLC-E /DPT Specification

Signaling

End to End signaling delay (normal and reverse)	< 40 msec
Pulse distortion (normal, reverse, pw > 25 msec)	< 15 msec
Ring detection	< 100 msec
Meter pulse detection frequencies	12 kHz, 16 kHz, ±20 Hz
Meter pulse amplitude	5mV - 4.5V
AC ringing load(20 Hz)	4kΩ +/- 10%
Ring detector Sensitivity	40 Vrms 16 - 55 Hz
Nominal DC input resistance	400Ω
Tip ground resistance	600Ω
Normal open interval detector threshold	10 mA +/- 3 mA
Maximum CO wiring resistance	200Ω
Battery reversal delay	40 msec

Audio

Companding	A Law
VF Input Impedance(provisionable)	600Ωor 900Ω
Nominal net Loss (Referenced 2 wire 600Ω)	0.0 dB +/- 0.4 dB
Maximum VF Overload level	+5 dBm
Frequency response(single ended)	300 Hz - 3.4 kHz : +0.4 / -0.7 dBm
2-wire return Loss (2 wire 600Ω single ended)	> 18 dB
4-wire hybrid balance(2 wire 600Ω)	> 30 dB
Longitudinal Balance	> 50 dB (400 Hz - 3.4 KHz)

Environmental

Operating temperature	-35°C to +60°C
Humidity	up to 98% at 35°C
Average Power Consumption	1.0 W

Dimensions

5.125" (13.018 cm) tall (standing up in CBA)
 10.5" (26.67 cm) long (from front of CBA to CBA backplane)
 0.563" (1.429 cm) thick (measured along faceplate - thickest point)
 0.5 lbs (0.23 Kilograms) weight

Compliance

CCITT G.713, G.714

4.4.9 Remote Subscriber Universal Voice Grade Channel Unit

The SLC-T (Subscriber Line Circuit for Terminal) and DPO (Dail Pulse Originating) are special versions of R-UVG (Remote Subscriber Universal Voice Grade). They have the same hardware and electrical features. R-UVG is the L-UVG's counterpart, SLC-T is the SLC-E counterpart, and DPO is the DPT counterpart, R-UVG/SLC-T/DPO are equipped at the Remote Subscriber Terminal. The R-UVG/SLC-T/DPO cards are direct-mapped to the corresponding L-UVG/SLC-E/DPT, separately. R-UVG/SLC-T/DPO establishes six dedicated circuits, thereby reducing the total number of spans that can be concentrated. The R-UVG/SLC-T/DPO card provides six, 2-wire switched analog circuits that support ground start, loop start, pulse metering, battery reversal signaling for applications such as PBX trunks. The following shows the faceplates of the R-UVG and SLC-T and DPO.

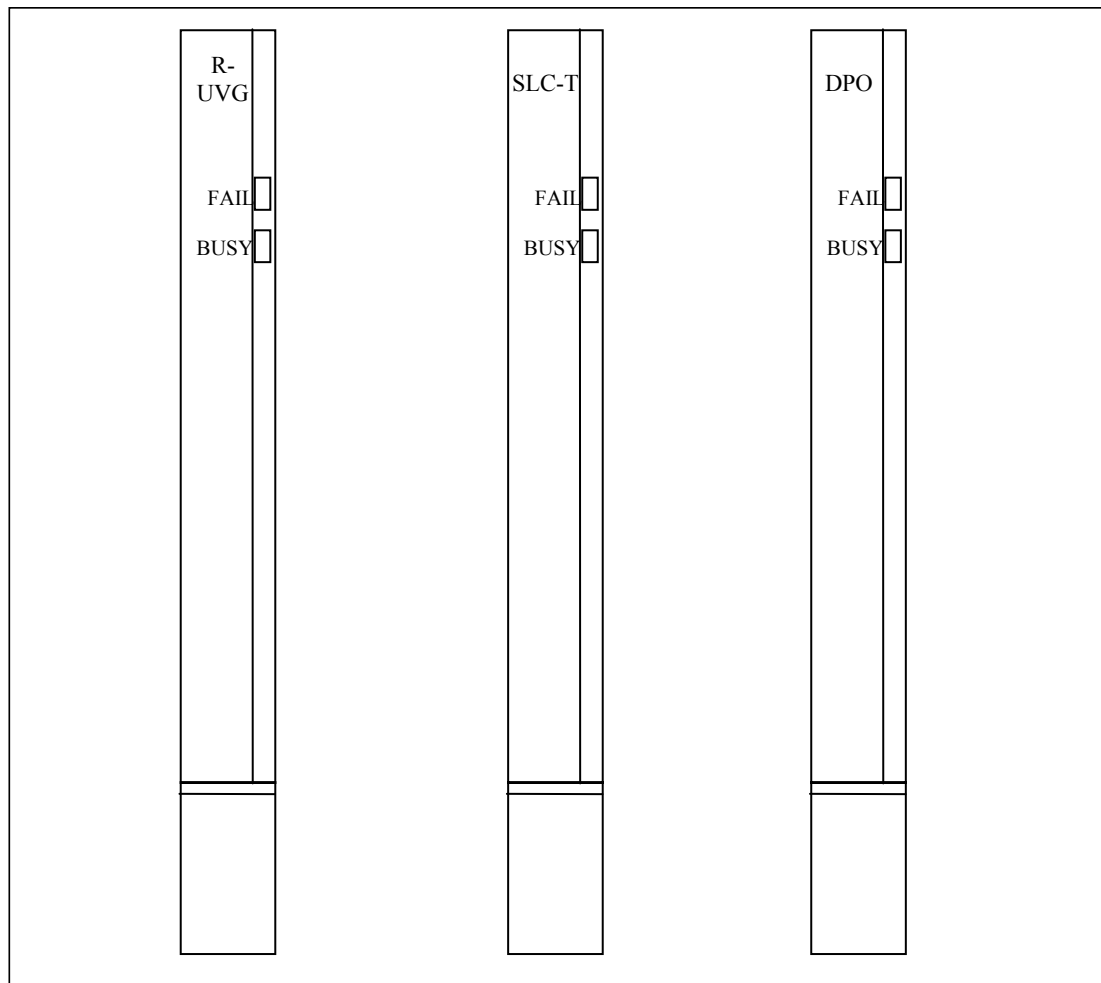

R-UVG/SLC-T/DPO cards provide ring cadence following, including ring-ping, on-hook transmission between ring bursts and forward disconnect. R-UVG/SLC-T/DPO also supports precision gain adjustment in 0.1 dB steps over a 12.0 dB range in addition to automatic transmission loss switching with loop length (four steps of 1dB each). R-UVG/SLC-T/DPO can also be used to provide international coin (payphone) service.

A green BUSY LED indicator, when lit, indicates that the circuit is busy or is being tested and should not be removed from service. A red FAIL LED indicates that the unit has failed. R-UVG/SLC-T/DPO features backplane metallic tip-ring access to enable testing using the Metallic Test Unit.

SLC-T (Subscriber Line Circuit for Terminal) and DPO (Dail Pulse Originating) are designed for Korea applications. Therefore they can support Korea R2 and Korea D4 signal.

Features

- Six Two-Wire Circuits per Card
- Provisionable gain
- Software selectable transmission gain 0.1dB steps
- 600Ω Terminating Impedance
- Ground start/loop start capability
- Forward disconnect
- Pulse metering and battery reversal applications
- On-hook transmission capability
- Remote Test Access to Metallic Tip and Ring
- SLC-T and DPO can support Korea R2 and Korea D4 signal
- Support DTMF and DP signalling

R-UVG/ SLC-T /DPO Specification

Signaling

End to End signaling delay (normal and reverse)	< 40 msec
Pulse distortion (pw > 25 msec)	< 5 msec
Ring detection	< 100 msec
Meter pulse detection frequencies	12 kHz, 16 kHz, ±0.1%
Meter pulse amplitude	0.5 Vrms - 200Ω
Maximum loop length excluding station	1800Ω
Off-Hook detection threshold	< 2.0kΩ
On-Hook detection threshold	> 7 kΩ
Loop current @ 44 volts	30mA short circuit, 2 x 400 battery feed
Open ckt. voltage - normal mode (batt.-52 v)	50 V
Open ckt. voltage - on hook transmission mode	44 V +/- 0.5V
Ring trip detection	> 2000Ω
Ring trip delay	< 50 msec

Audio

Companding	A Law
VF Input Impedance(provisionable)	600Ω
Nominal net Loss (Referenced 2 wire 600Ω)	0.0 dB +/- 0.4 dB off-hook 1 dB +/- 1 dB on-hook
Maximum VF Overload level	+5 dBm
Frequency response(single ended)	300 Hz - 3.4 kHz : +0.4 / -0.7 dBm
2-wire return Loss (2 wire 600Ω single ended)	> 18 dB
4-wire hybrid balance(2 wire 600Ω)	> 30 dB
Longitudinal Balance > 65 dB (400 Hz - 3.4 KHz)	

Environmental

Operating temperature	-35°C to +60°C
Humidity	up 98% at 35°C
Average Power Consumption	2.0 W

Dimensions

- 5.125" (13.018 cm) tall (standing up in CBA)
- 10.5" (26.67 cm) long (from front of CBA to CBA backplane)
- 0.563" (1.429 cm) thick (measured along faceplate - thickest point)
- 0.5 lbs (0.23 Kilograms) weight

Compliance

CCITT G.713, G.714

4.5 Digital Channel Units

4.5.1 LET ISDN Channel Unit

The HTC-1100E ISDN channel unit (LI-ISDN) provides two ISDN "U" circuits. The LI-ISDN (LUNT) is designed to transport the 2B+D data from the Local exchange as three 64 Kbps timeslots through the HTC-1100E to the remote terminal where the RI-ISDN recreates the physical 2B+D format for relay to the customer. The LI-ISDN channel units utilize mixed analog and digital signal processing circuit technology as described in TR-397. Its faceplate is shown on this page.

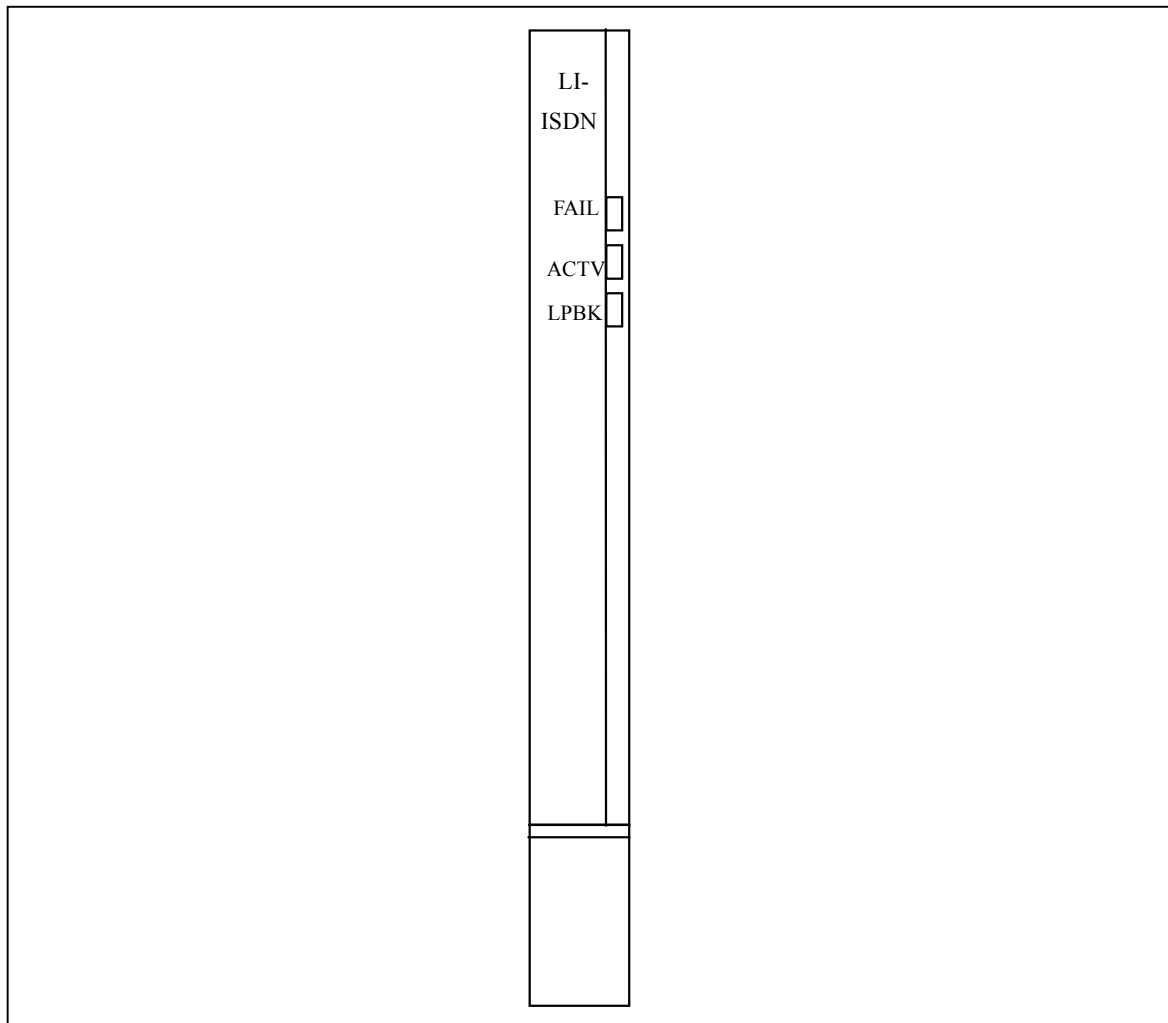

Each LI-ISDN channel unit provides two ISDN lines. The LI-ISDN uses 2B1Q (2 binary 1 quaternary) line coding for full-duplex transmission at 160 Kbps data rate. The transmission format provides two 64 Kbps channels (B-channels), one 16 Kbps channels (D-channel), one 12Kbps synchronous word, and one 4 Kbps control channel. The LI-ISDN is a slave digital subscriber line transceiver, functions like "NT1", and link to LT exchange.

The LI-ISDN responds to mp-EOC message compliance Bellcore TR-TSY-000829. About overhead indicator bit. In addition to EOC, CRC and FEBE, other overhead bits are transparency.

The LI-ISDN channel unit provides a DC termination to sealing current as well as loop test

verification. The LI-ISDN will support 3-channel TDM multiplexing format.

There are three LED indicators on the LI-ISDN channel unit front panel. A green ACTV LED indicates the unit is busy. A red FAIL LED indicates that the unit has failed. A yellow LOOP LED indicates loopback.

Features

- Two ISDN circuits per card
- 3-channel TDM
- Loopbacks as described in TR-397(2B+D, B1, B2 or B1+B2)
- DC test signature

LI-ISDN Specification

Signaling

Line coding	2B1Q
Data rate (Throughput)	160 Kbps
Loopback modes	Local

Analog Parameters

Equalization	Receive	<40 dB attenuation @ 40 kHz
	Transmit	12.5 dB (2.5 Vpk)
Input impedance		135 Ω ± 5 %
Sealing current termination		400 Ω

Start-up

Cold start-up	LT↔LUNT↔LULT↔NT1	<80 sec
Warm-start	Deactivation→Activation	<1 sec

Environmental

Operating temperature	-35°C to +60°C
Humidity	up 98% at 35°C
Average Power Consumption	1.5 W

Dimensions

5.125" (13.018 cm) tall (standing up in CBA)
 10.5" (26.67 cm) long (from front of CBA to CBA backplane)
 0.563" (1.429 cm) thick (measured along faceplate - thickest point)

Weight

0.35 lbs. (0.16 Kilograms)

Compliance

ETSI ETR 080
 TR-NWT-00039
 ITU-T G.797
 Chunghwa Telecom Co., Ltd. ME 0200-2
 ANSI T1.601-1992
 Bellcore TR-TSY-000829 Issue 1, November 1989.

4.5.2 RST ISDN Channel Unit

The HTC-1100E RST ISDN channel unit (RI-ISDN) provides two ISDN “U” circuits. The RI-ISDN (LULT) recreates the physical 2B+D format for relay to the customer from the LI-ISDN unit. The RI-ISDN channel units utilize mixed analog and digital signal processing circuit technology as described in TR-397. Its faceplate is shown on this page.

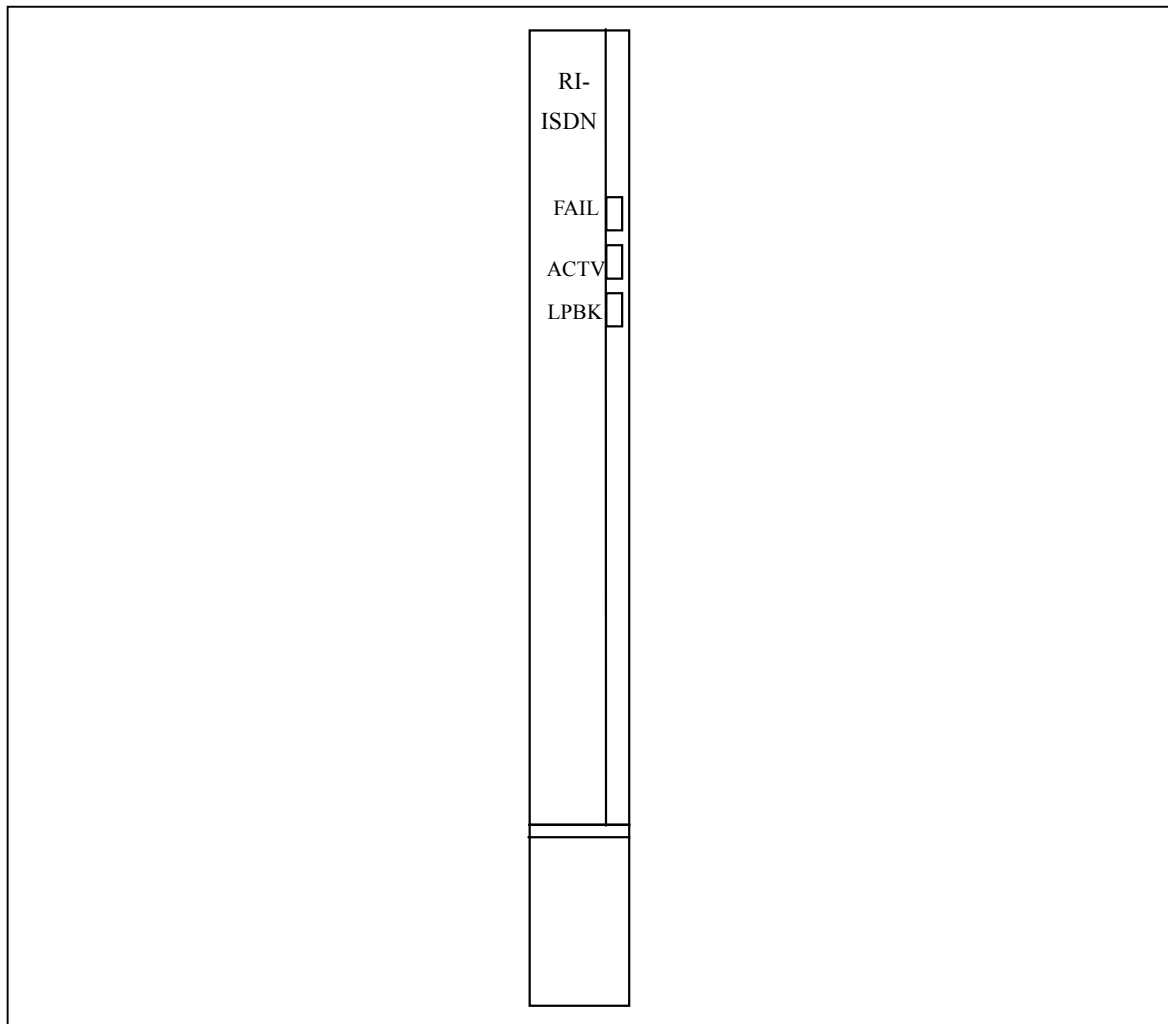

Each RI-ISDN channel unit provides two ISDN lines. The RI-ISDN uses 2B1Q (2 binary 1 quaternary) line coding for full-duplex transmission at 160 Kbps data rate. The transmission format provides two 64 Kbps channels (B-channels), one 16 Kbps channel (D-channel), one 12Kbps synchronous word, and one 4 Kbps control channel. The RI-ISDN is a master digital subscriber line transceiver, functions like “LT”, and link to NT1.

The RI-ISDN responds to mp-EOC message compliance Bellcore TR-TSY-000829. About overhead indicator bit. In addition to EOC, CRC and FEBE, other overhead bits are transparency.

The RI-ISDN channel units could provide -92 Vdc of power feeding. The RI-ISDN will support 3-channel TDM as well as other manufacturers D channel multiplexing formats. The RI-ISDN Channel Unit has an approximate working range of 5.49 km (18Kft) over 0.5mm (#24 AWG) cable.

There are three LED indicates on the RI-ISDN channel unit front panel. A green ACTV LED

indicates the unit is busy. A red FAIL LED indicates that the unit has failed. A yellow LOOP LED indicates loopback. The RI-ISDN features backplane metallic tip-ring access to enable testing using the Metallic Test Unit (MTU).

Features

- Two ISDN circuits per card
- 3-channel TDM
- 2B+D, B1 only, or B2 only loopbacks
- Power feeding (92VDC)
- Responds to messages
- Remote access to metallic tip and ring

RI-ISDN Specification		
Signaling		
Line coding		2B 1Q
Data rate (Throughput)		160 Kbps
Loopback modes		Local
Analog Parameters		
Equalization	Receive	<40 dB attenuation @ 40 kHz
	Transmit	12.5 dB (2.5 Vpk)
Input impedance		135 Ω \pm 5 %
Sealing current termination		400 Ω
Start-up		
Cold start-up	LT \leftrightarrow LUNT \leftrightarrow LULT \leftrightarrow NT1	<80 sec
Warm-start	Deactivation \rightarrow Activation	<1 sec
Environmental		
Operating temperature		-35 $^{\circ}$ C to +60 $^{\circ}$ C
Humidity		up to 98% at 35 $^{\circ}$ C
Average Power Consumption		1.5 W (excluding consumption for sealing current or power feeding)
Dimensions	5.125" (13.018 cm) tall (standing up in CBA)	
	10.5" (26.67 cm) long (from front of CBA to CBA backplane)	
	0.563" (1.429 cm) thick (measured along faceplate - thickest point)	
Weight	0.35 lbs. (0.16 Kilograms)	
Compliance	ETSI ETR 080 TR-NWT-00039 ITU-T G.797 Chunghwa Telecom Co., Ltd. ME 0200-2 ANSI T1.601-1992 Bellcore TR-TSY-000829 Issue 1, November 1989.	

4.5.3 Asynchronous Data Channel Unit (ADU)

The HTC-1100E Asynchronous Data Channel Unit (ADU) provides low bit rate asynchronous interfaces to HTC-1100E for point-to-multipoint service. The ADU is equipped in both the LET and RST(s). It operates at 300, 600, 1200, 2400, 4800, 9600 or 19200, 38400 bits second.

The ADU unit supports two data channels using V.28 electrical interface. Its faceplate is shown on this page.

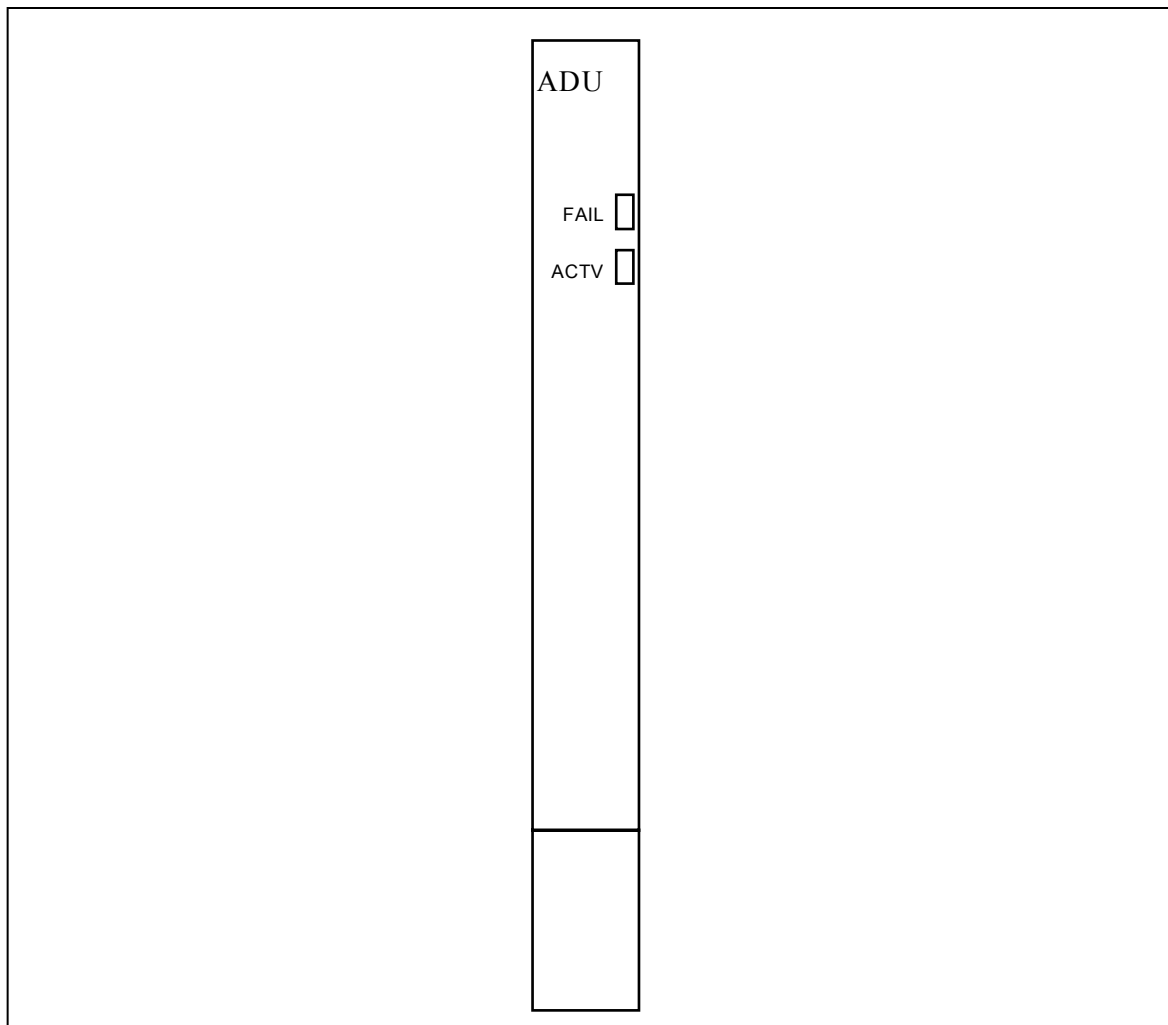

The ADU provides optional error correction through the craft interface terminal when very low bit error rate transmission is required. The ADU may also be provisioned to optimize E1 capacity by multiplexing several low rate asynchronous data interfaces into a single 64 Kbps E1 timeslot.

The ADU provides alarm indication, and rate provisioning from a remote site using a craft interface terminal.

There are two LED indicators on the ADU front panel. A green ACTV LED indicates the unit is active. A red FAIL LED indicates that the unit has failed.

Features

- Two multi-bit-rate circuits per card

HTC-1100E System Description

- V.28 electrical interface
- Multiple Error Correction Protocols
- Asynchronous 300, 600, 1200, 2400, 4800, 9600 or 19200, 38400 bps
- For both LET and RST
- Low Power Dissipation

ADU Specification	
<u>Data Handling</u>	
1200 bps with error correction	2400 bps with error correction
4800 bps with error correction	9600 bps
19,200 bps	
Distortion at maximum rate	< 9 %
End to End data delay	< 2 bits
<u>Electrical Interfaces</u>	
ITU-T V.28	
V.28 Floating	2 channels/card
Current Loop	±2 mA 5%
<u>Environmental</u>	
Operating temperature	-35°C to +60°C
Humidity	up to 98% at 35°C
Average Power Consumption	3.0 W
<u>Dimensions</u>	
	5.125" (13.018 cm) tall (standing up in CBA)
	10.5" (26.67 cm) long (from front of CBA to CBA backplane)
	0.563" (1.429 cm) thick (measured along faceplate - thickest point)
<u>Weight</u>	
	0.5 lbs (0.23 Kilograms)
<u>Compliance</u>	
	V.28

4.5.4 Synchronous Data Channel Unit

The HTC-1100E Synchronous Data Channel Unit (SDU) provides a multi-bit-rate synchronous interface to HTC-1100E for data service. The SDU is equipped in both the LET and RST(s). It operates at 0.6, 1.2, 2.4, 4.8, 9.6, 19.2, 38.4, 48, 56, or 64 Kbps.

The SDU supports one data channels per unit using ITU-T G.703, ITU-T V.11/X.21 or V.35/V.28 electrical interfaces. Its faceplate is shown on this page.

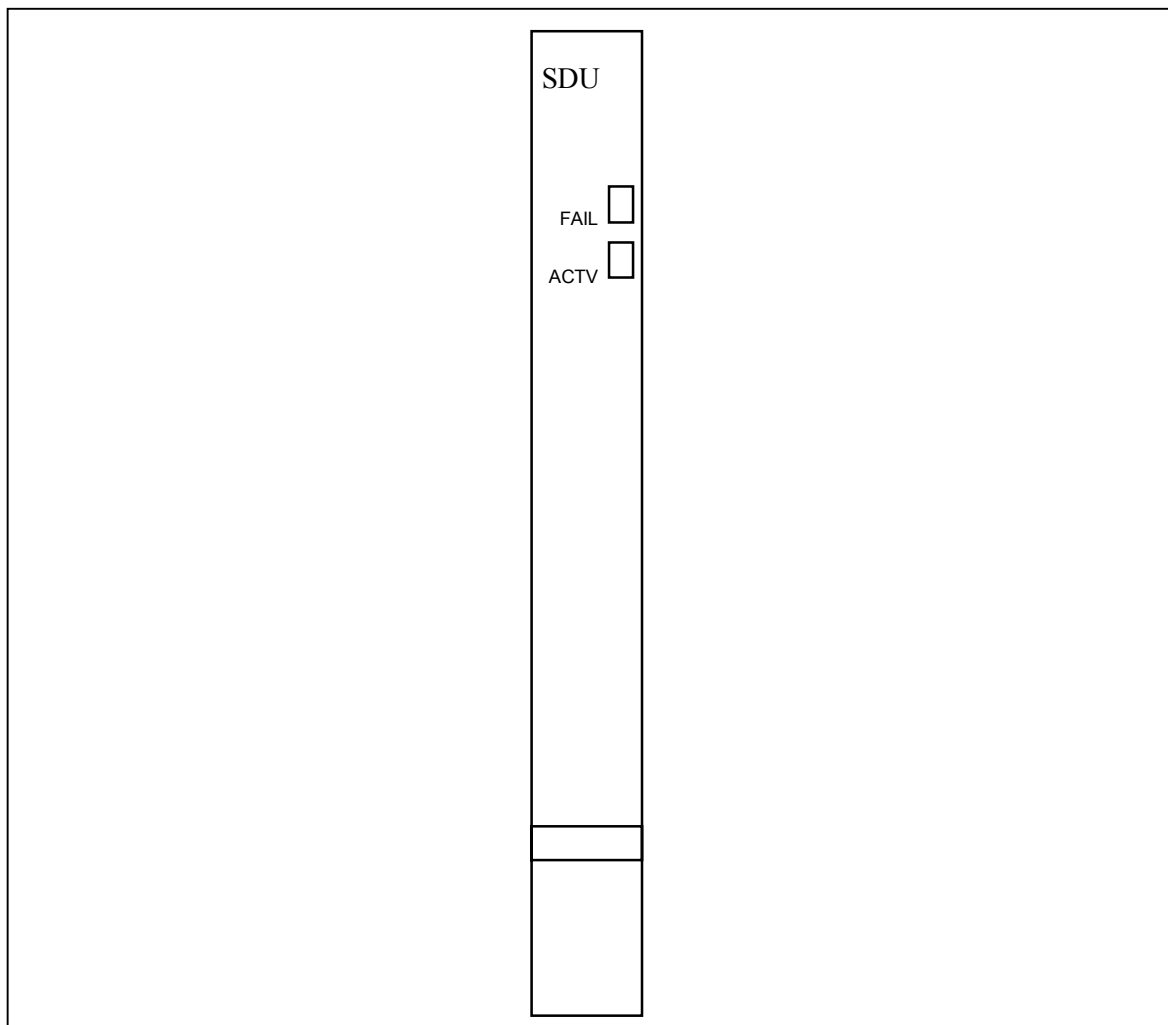

The SDU may be used in all types of public and private data networks where synchronous data with minimum delay is required.

When used in its synchronous mode, synchronization is achieved by locking the system clock to an external 2 Mbps reference, which is terminated on the LET backplane, or using one of the E1 streams as a reference clock.

The SDU provides alarm indication, and rate provisioning from a remote site using a craft interface terminal.

There are two LED indicators on the SDU front panel. A green ACTV LED indicates the unit is active. A red FAIL LED indicates that the unit has failed. The channel unit features backplane metallic tip-ring access to enable testing using the Metallic Test Unit.

Features

- One multi-bit-rate circuit per card
- V.11/X.21, V.28 or V.35 Electrical Interfaces
- Multiple Error Correction Protocols
- 0.6, 1.2, 2.4, 4.8, 9.6, 19.2, 38.4, 48, 56, or 64 Kbps Sync Data Rates
- LET or RST Applications Supported
- Low Power Dissipation

SDU Specification	
<u>Data Handling</u>	
48, 56 or 64 Kbps	2 interfaces per unit
48 or 56 Kbps Multiplexing	V.110
<u>Electrical Interfaces</u>	
ITU-T V.11	
Differential Voltage Swing	≥ 2 Vpk @ 100 Ω
Logic level (1)	≥ -2 Vpk
Logic level (0)	$\leq +2$ Vpk
Impedance (input)	100 Ω
ITU-T V.35	
Logic level (1)	-1.6 V
Logic level (0)	+0.6 V
Impedance (input)	100 Ω
ITU-T V.28	
V.28 Floating 2 channels/card	
Current Loop	± 2 mA 5%
<u>Environmental</u>	
Operating temperature	-35 $^{\circ}$ C to +60 $^{\circ}$ C
Humidity	up to 98% at 35 $^{\circ}$ C
Average Power Consumption	3.0 W
<u>Dimensions</u> 5.125" (13.018 cm) tall (standing up in CBA)	
	10.5" (26.67 cm) long (from front of CBA to CBA backplane)
	0.563" (1.429 cm) thick (measured along faceplate - thickest point)
<u>Weight</u>	0.5 lbs (0.23 Kilograms)
<u>Compliance</u>	ITU-T V.11, V.28, V.35

4.5.5 N64P Channel Unit

The HTC-1100E N64P channel unit provides 1 circuits N×64kbps (N = 1.. 30) per card. This multiple rate can be setting by HTC-1100E craft interface. The N64P card plug in LET and RST of the HTC-1100E. In the LET N64P card and RST N64P card connect with Local Exchange and subscriber DTE equipments by V.35/V.36 interface , respective.

There are three LED indicators on the N64P channel unit front panel. A green ACTV LED indicates the unit is active and must not be unplugged without first removing traffic. A red FAIL LED indicates that the unit has failed. A yellow LPBK LED indicates loop back.

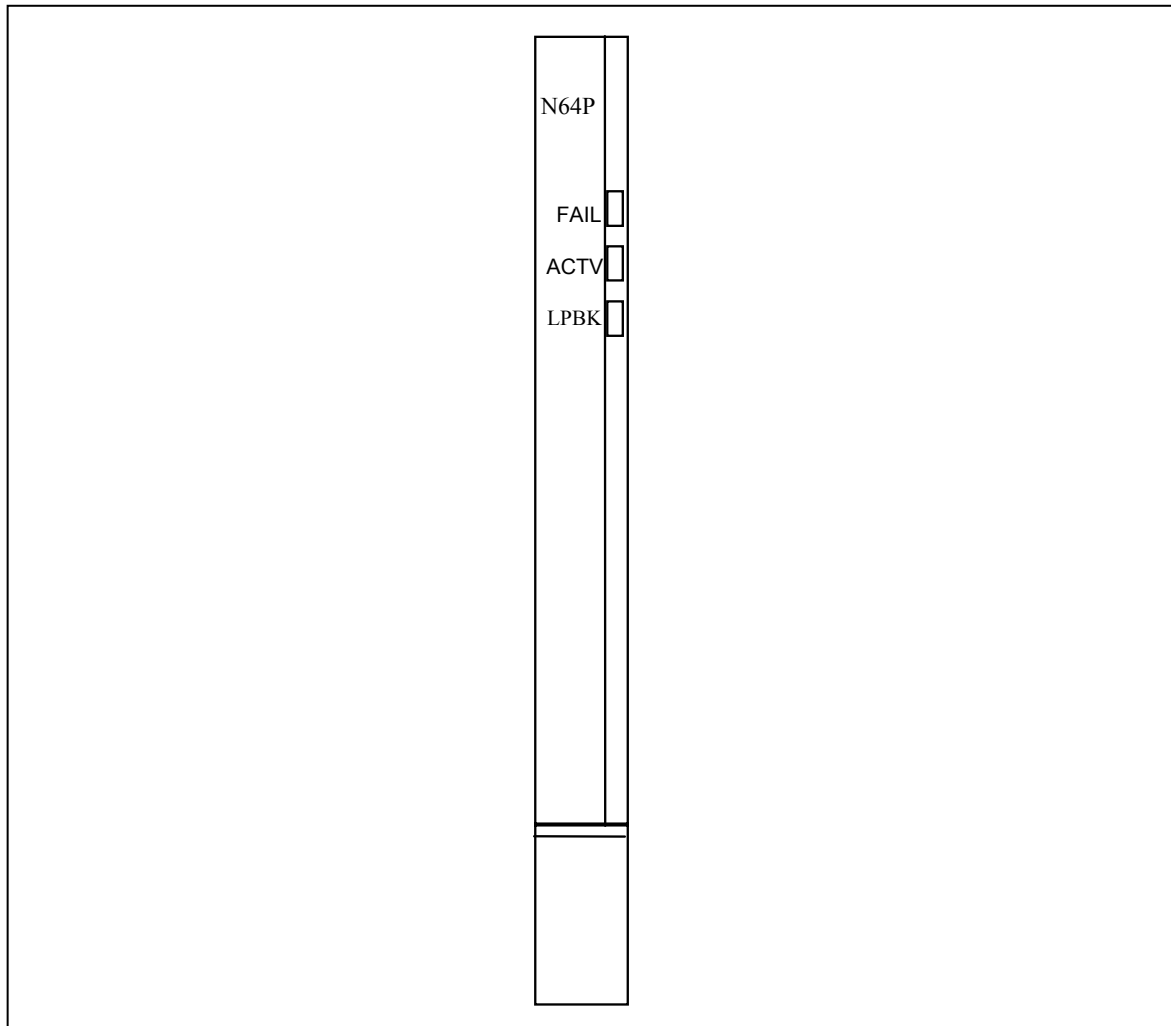

Features

- Provides N×64 kbps (N = 1 .. 30) per card
- Provides V.35/V.36 interface
- Remote/local Loop back diagnostics
- Low power dissipation

N64P Specification	
<u>Signaling</u>	
Data Rate	N×64 kbps (N=1...30)
Loopback Modes	Local , Remote
<u>Electrical Interfaces</u>	
ITU-T V.11	
Differential Voltage Swing	≥ 2 Vpk @ 100Ω
Logic level (1)	≥ -2 Vpk
Logic level (0)	≤ +2 Vpk
Impedance (input)	100Ω
ITU-T V.35	
Logic level (1)	-1.6 V
Logic level (0)	+0.6 V
Impedance (input)	100Ω
<u>Environmental</u>	
Operating temperature	-35°C to +60°C
Humidity	up to 98% at 35°C
Average Power Consumption	1.4 W
<u>Dimensions</u> 5.125" (13.018 cm) tall (standing up in CBA)	
	10.5" (26.67 cm) long (from front of CBA to CBA backplane)
	0.563" (1.429 cm) thick (measured along faceplate - thickest point)
<u>Weight</u>	0.42 lbs (0.19 Kilograms)
<u>Compliance</u>	ITU-T V.11, V.35

4.5.6 E1 Asynchronous Channel Unit

The HTC-1100E E1 Asynchronous Transceiver provides a G.703 E1 rate interface. It operates at the E1 rate of 2.048 Mbps.

The E1AX is intended for use in applications that require transport of intact E1 signals from customer premise to the local exchange. The E1AX can be used to deliver intact E1 services to a customer's G.703 signaling equipment. The E1AX does not provide sealing current. Its faceplate is shown on this page.

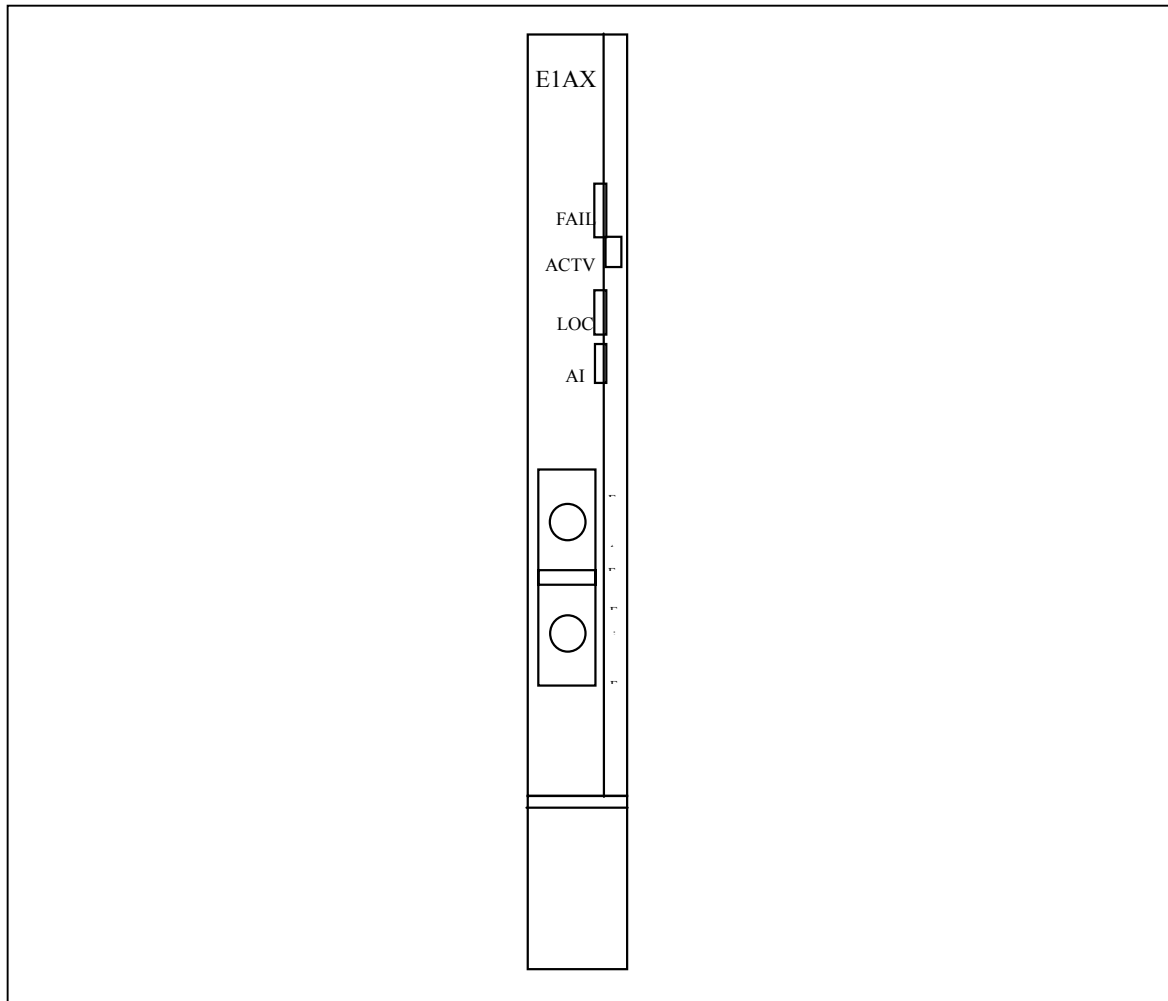

The E1AX performs no signaling conversion or data link termination, only intact E1 transport. Line coding is HDB3. The transceiver has selectable alarm thresholds, BER calculation, and alarm history.

There are four LED indicators on the E1AX front panel. A green ACTV LED indicates the unit is active and must not be unplugged without first removing traffic. A red FAIL LED indicates that the unit has failed. A red LOC LED indicates features of the incoming signal. A blue AIS (Alarm Indication Signal) indicates that a piece of telecommunications equipment linked, directly or indirectly, to this card has failed. The transceiver features front panel jack access for testing and monitoring.

Features

- One Asynchronous, Non Line-Powering E1 Circuit per card
- Intact E1 Transport
- Customer E1 service capability
- Extensive Loopback Diagnostics
- Front Panel Jack Access for Testing and monitoring
- Low Power Dissipation

E1AX Specification	
<u>Signaling Features</u>	
Framing	Unframed or framed
Line Coding	HDB3
Loopback Modes	Local, Remote
<u>Analog Parameters</u>	
Equalization	Receive Automatic Line Build Out (15 dB attenuation)
	Transmit Fixed 3.0 Vpk±0.3 Vpk
Input Impedance	120Ω
<u>Environmental</u>	
Operating temperature	-35°C to +60°C
Humidity	up to 98% at 35°C
Max. Power Consumption	2.5 W
<u>Dimensions</u>	
	5.125" (13.018 cm) tall (standing up in CBA)
	10.5" (26.67 cm) long (front of CBA to CBA backplane)
	0.563" (1.429 cm) thick (along faceplate - thickest point)
<u>Weight</u>	0.5 lbs (0.23 Kilograms)
<u>Compliance</u>	
Jitter	ITU-T G.713, I.431 Draft
Cable Interface	ITU-T G.703

4.5.7 E1 Channel Unit

The HTC-1100E E1 Transceiver provides a G.703 E1 rate interface. It operates at the E1 rate of 2.048 Mbps.

The E1X is intended for use in applications that require transport of intact E1 signals from customer premise to the local exchange. The E1X can be used to deliver intact E1 services to a customer's G.703 signaling equipment. The E1X does not provide sealing current. Its faceplate is shown on this page.

The E1X performs no signaling conversion or data link termination, only intact E1 transport. Line

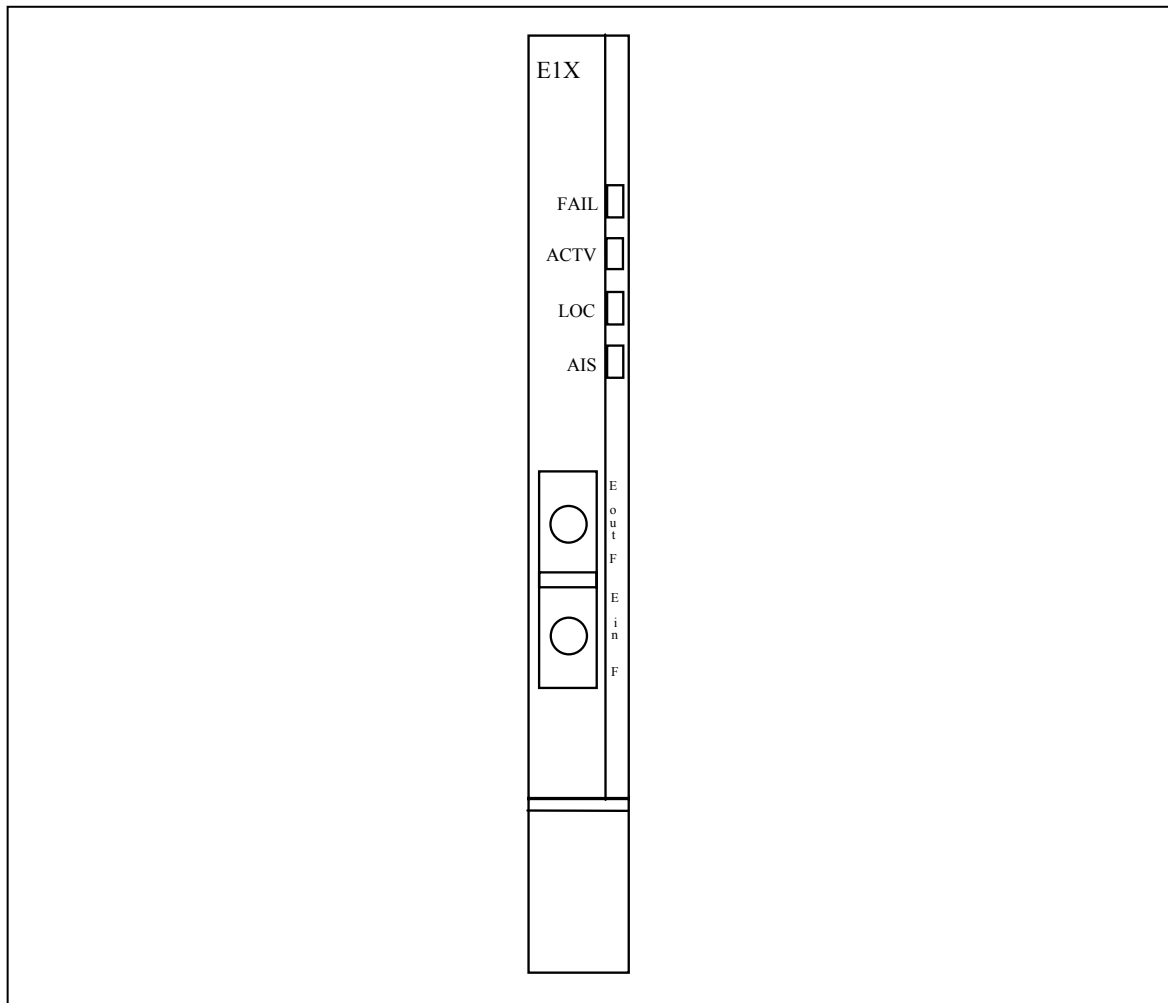

coding is HDB3. The transceiver has selectable alarm thresholds, and alarm history.

There are four LED indicators on the E1X front panel. A green ACTV LED indicator the unit is active and must not be unplugged without first removing traffic. A red FAIL LED indicates that the unit has failed. A red LOC LED indicates features of the incoming signal. A blue AIS (Alarm Indication Signal) indicates that a piece of telecommunications equipment linked, directly or indirectly, to this card has failed. The transceiver features front panel jack access for testing and monitoring.

Features

- One Synchronous, Non Line-Powering E1 Circuit per card

HTC-1100E System Description

- Intact E1 Transport
- Customer E1 service capability
- Extensive Loopback Diagnostics
- Front Panel Jack Access for Testing and monitoring
- Low Power Dissipation

E1X Specification		
<u>Signaling Features</u>		
Framing	Unframed	
Line Coding	HDB3	
Loopback Modes	Local, Remote	
<u>Analog Parameters</u>		
Equalization	Receive	Automatic Line Build Out (15 dB attenuation)
	Transmit	Fixed 3.0 Vpk±0.3 Vpk
Input Impedance	120Ω	
<u>Environmental</u>		
Operating temperature	-35°C to +60°C	
Humidity	up to 98% at 35°C	
Max. Power Consumption	2.5 W	
<u>Dimensions</u>		
	5.125" (13.018 cm) tall (standing up in CBA)	
	10.5" (26.67 cm) long (front of CBA to CBA backplane)	
	0.563" (1.429 cm) thick (along faceplate - thickest point)	
<u>Weight</u>		
	0.5 lbs (0.23 Kilograms)	
<u>Compliance</u>		
Jitter	ITU-T G.713, I.431 Draft	
Cable Interface	ITU-T G.703	

4.5.8 DD1.5 DS1 Channel Unit

The HTC-1100E DD1.5 T1 Transceiver provides a cross-connect level T1 rate interface. It operates at the T1 rate of 1.544 Mbps. The DD1.5 is intended for use applications that require transport of T1 signals from customer premise to the local exchange. The DD1.5 provides T1 signal for transport throughout the network. The DD1.5 can be used to deliver T1 services to a customer's G.703 signaling equipment. Its Maximum transmission distance is 655 feet. It does not provide sealing current. Its faceplate is shown on this page.

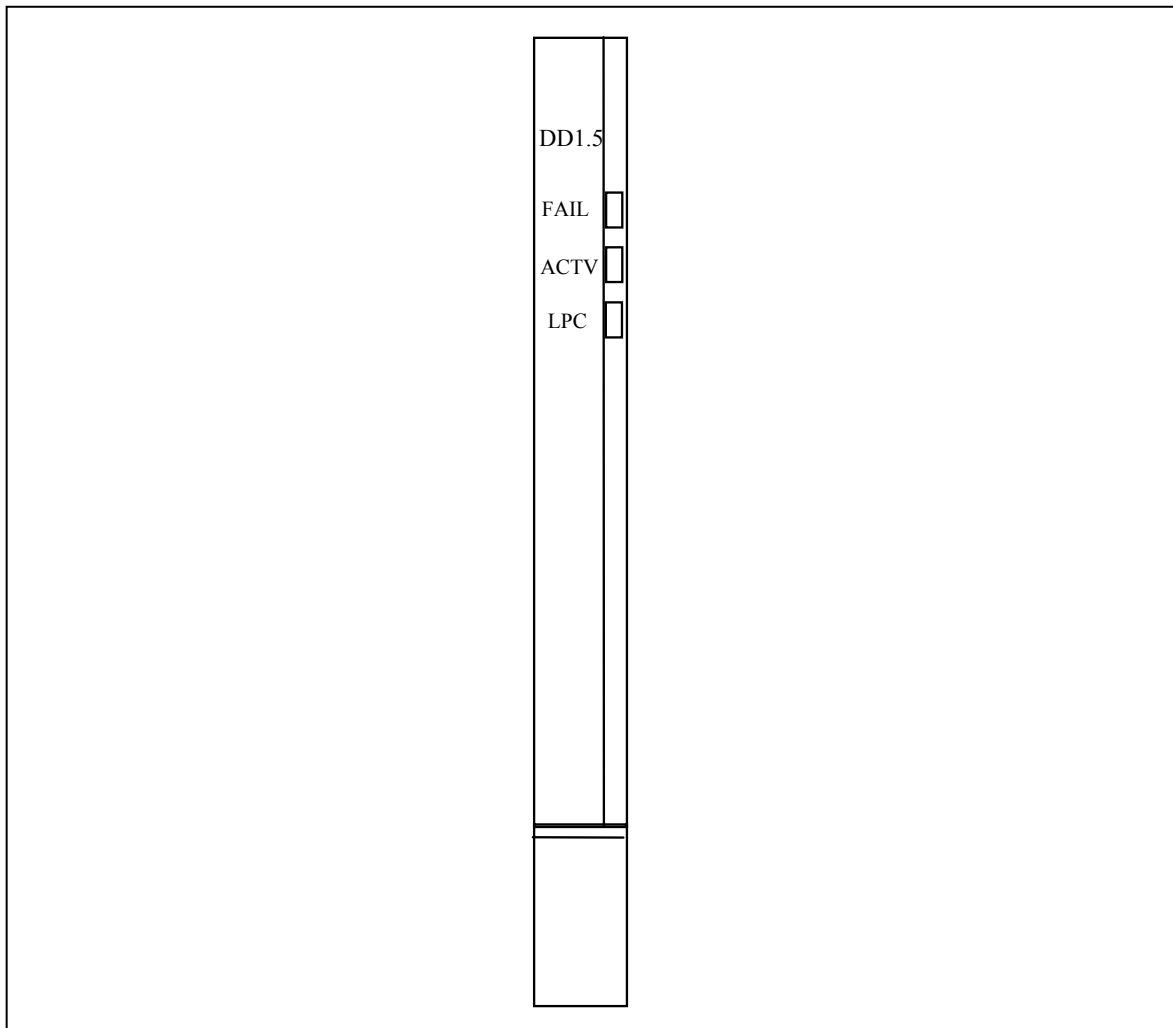

The DD1.5 performs no data link termination. Line coding is B8ZS and AMI.

There are three LED indicators on the DD1.5 front panel. A green ACTV LED indicates the unit is active and must not be unplugged without first removing traffic. A red FAIL LED indicates that the unit has failed. A red LOC LED indicates a failure of the incoming signal.

Features

- One non line-powering T1 circuit per card
- Customer T1 service capability
- Extensive loopback diagnostics

DD1.5 Specification

Signaling Features

Framing	Unframed or framed
Line Coding	B8ZS/AMI
Loopback Modes	Local, Remote

Analog Parameters

Equalization	Receive	Automatic Line Build Out (15 dB attenuation)
	Transmit	Fixed 3.0 V _{pk} ± 0.6 V _{pk}
Input Impedance	100 Ω	

Environmental

Operating temperature	-35°C to +60°C
Humidity	up to 98% at 35°C
Max. Power Consumption	2.5 W

Dimensions

5.125" (13.018 cm) tall (standing up in CBA)
 10.5" (26.67 cm) long (front of CBA to CBA backplane)
 0.563" (1.429 cm) thick (along faceplate - thickest point)

Weight

0.5 lbs (0.23 Kilograms)

Compliance

Jitter	CCITT G.703
Cable Interface	CCITT G.703

4.5.9 Co-directional 64 kbps Channel Unit

The HTC-1100 G.703 co-directional 64kbps (CO64) channel unit provides 3 circuits per card. The CO64 card may be used in LET and RST of the HTC-1100. In the LET CO64 card use 4 wire connect with local exchange. The CO64 card located at RST connects with subscriber's DCT equipment.

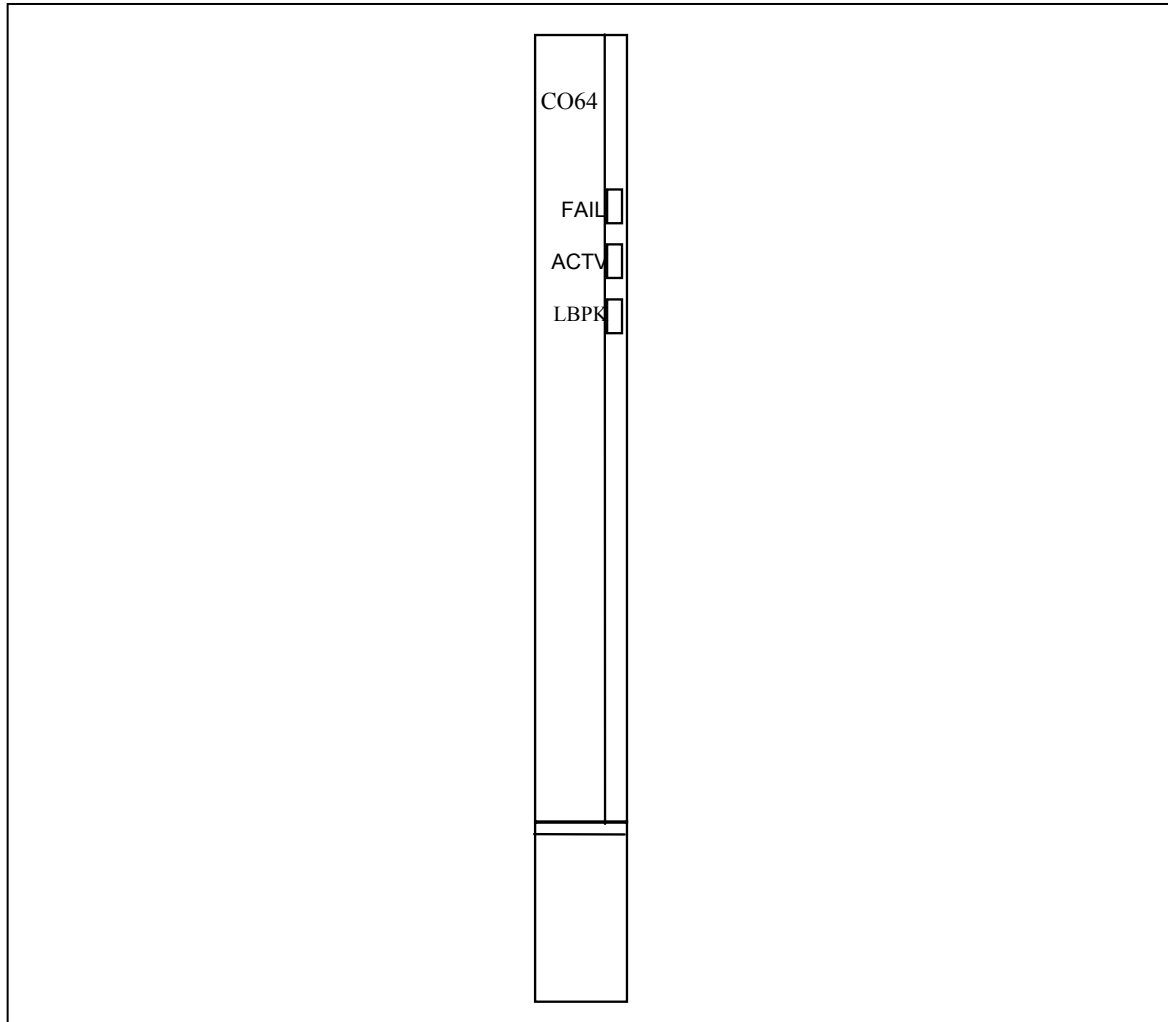

There are three LED indicators on the CO64 channel unit front panel. A green ACTV LED indicates the unit is active and must not be unplugged without first removing traffic. A red FAIL LED indicates that the unit has failed. A yellow LBPK LED indicates loop back.

Features

- Provides three 64 kbps circuits per card
- High voltage protection
- Loop back diagnostics
- Low power dissipation

CO64 Specification	
<u>Signaling</u>	
Data rate	64kbps
Loopback Modes	Remote
<u>Simulation Parameters</u>	
Load Impedance	120 ohm
<u>Environmental</u>	
Operating temperature	-35°C to +60°C
Humidity	up to 98% at 35°C
Average Power Consumption	3.0 W
<u>Dimensions</u>	
5.125"(13.018 cm) tall (standing up in CBA)	
10.5"(26.67 cm) long (from front of CBA to CBA backplane)	
0.563"(1.429 cm) thick (along faceplate-thickest point)	
<u>Weight</u>	
0.5 lbs. (0.23 Kilograms)	
<u>Compliance</u>	ITU-T G.703
<u>Cable Interface</u>	4 Wire

4.5.10 Digital Data 64Kbps

The Remote Subscriber Digital Data 64Kbps Channel Unit (DD64) provides a multi-rate, full duplex, and synchronous data interface for transmitting and receiving data. The DD64 may be used at LET or RST. It operates at the DDS defined data rates including all the sub-rates and 64Kbps clear channel mode. The transmission distance could reach to 5.5Km based on 0.4mm copper wire at 64Kbps. Receive cable equalization is adaptive depending on cable length.

The following shows the faceplate of the DD64.

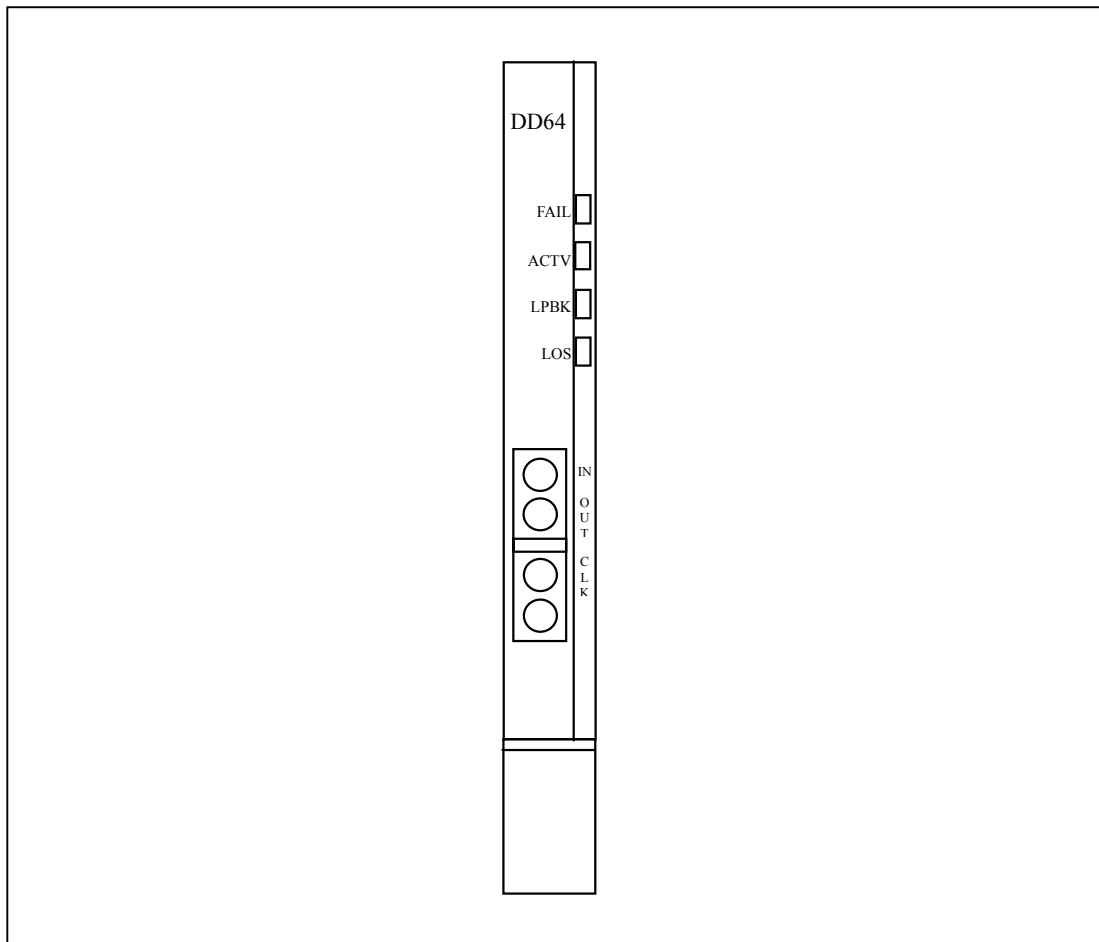

The DD64 can perform zero suppression, BCH error correction and majority vote error correction. In addition several customer-controlled loopbacks are supported. The DD64 card also has DDS Secondary Channel capability.

There are four LED indicators on the DD64 transceiver front panel. A green ACTV LED indicates the unit is active. A red FAIL LED indicates that the unit has failed. An amber LPBK LED indicates that the unit is in loopback while a red LOS LED indicates that the unit has lost signal. The channel unit features front panel jack access for testing and monitoring.

Features

- One multi-rate DDS circuit per card
- Data rates of 2.4, 4.8, 9.6, 19.2, 56 and 64Kbps
- Multiple error correction protocols
- Secondary channel support
- Latching and alternating loopbacks
- Optional zero suppression
- Front panel jack access for test and monitoring

DD64 Specification

Signaling

Data rates	2.4,4.8,9.6,19.2,56 & 64Kbps
Zero suppression	All rates except 64Kbps
Secondary channel	2.4 Kbps - 133 bps 4.8 Kbps - 266 bps 9.6 Kbps - 533 bps 19.2 Kbps - 1066 bps 56 Kbps - 2666 bps
Loopback modes	Latching,alternating OCU Channel Loopback
Error correction (19.2 - 64 Kbps)	BCH parity code
Error correction (2.4 - 9.6 Kbps)	Majority vote
Loop length	12 kft

Analog Parameters

Equalization	Receive(@ 1*10 ⁻⁹)	-43 dB (56,64 Kbps) -34 dB (2.4 - 19.2 Kbps)
Input Impedance		135Ω ± 5 %
Sealing current		< 25 mA

Environmental

Operating temperature	-35°C to +60°C
Humidity	up to 98% at 35°C
Average Power Consumption	3.0 W

Dimensions

5.125" (13.018 cm) tall (standing up in CBA)
10.5" (26.67 cm) long (from front of CBA to CBA backplane)
0.563" (1.429 cm) thick (measured along faceplate - thickest point)

Weight

0.5 lbs (0.23 Kilograms)

Compliance

ITU-T G.713, G.714

Cable Interface

4Wire

4.5.11 ISDN Digital Subscriber Line Channel Unit

The HTC-1100E ISDN Digital Subscriber Line channel unit (IDSL) provides two ISDN “U” circuits. The IDSL recreates the physical 2B+D format for relay to the customer. The IDSL channel units utilize mixed analog and digital signal processing circuit technology as described in TR-397. Its faceplate is shown on this page.

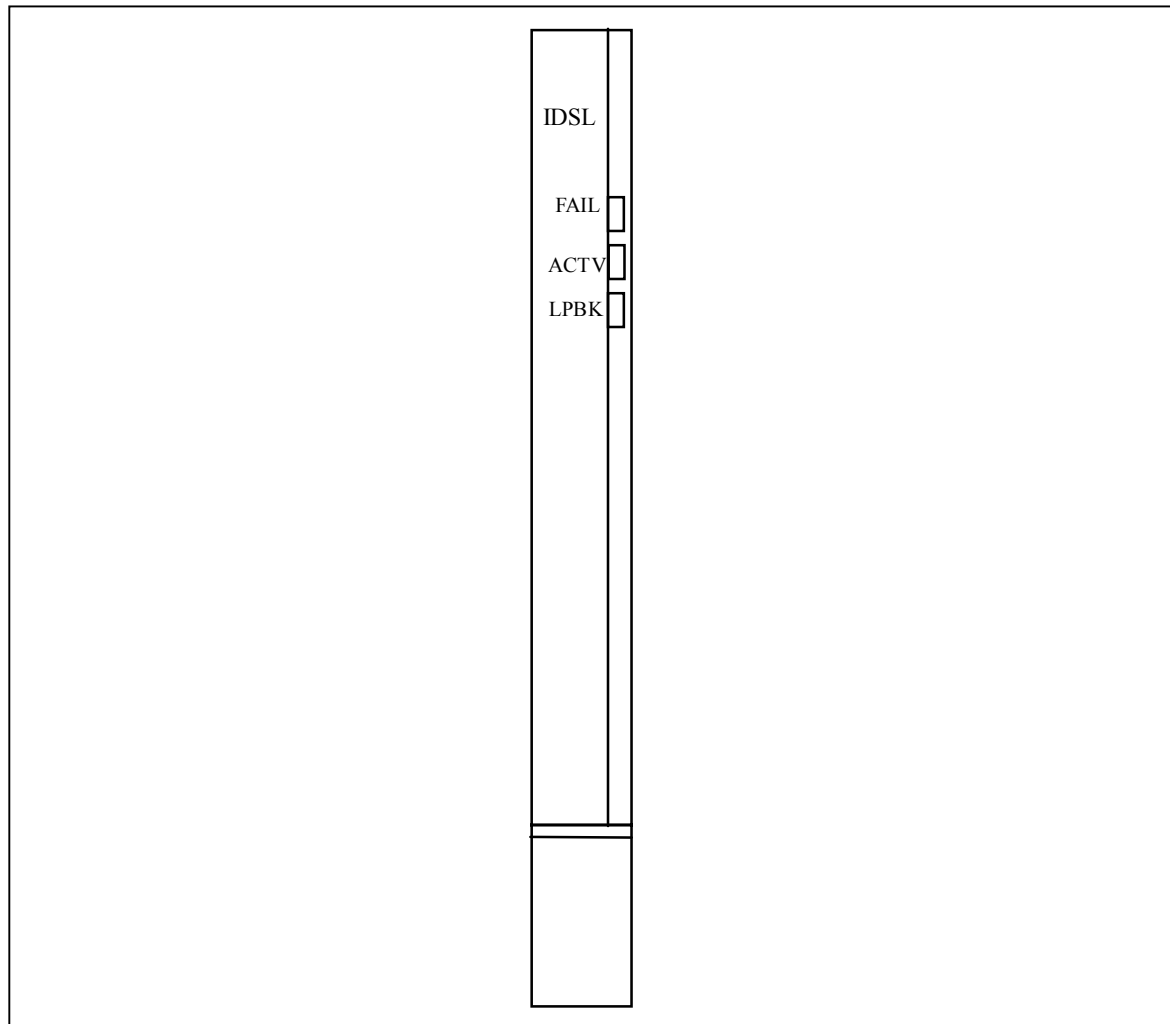

Each IDSL channel unit applies ISDN technology and provides two ISDN lines. The IDSL uses 2B1Q (2 binary 1 quaternary) line coding for full-duplex transmission at 160 Kbps data rate. The transmission format provides one 64 Kbps, two 64 Kbps or one 128Kbps channels (B-channels) data service.

The IDSL channel units don't provide power feeding. The IDSL will support 2-channel TDM. The IDSL Channel Unit has an approximate working range of 5.49 km (18Kft) over 0.5mm (#24 AWG) cable.

There are three LED indicates on the IDSL channel unit front panel. A green ACTV LED indicates the unit is busy. A red FAIL LED indicates that the unit has failed. A yellow LOOP LED indicates loopback tacking place. The IDSL features backplane metallic tip-ring access to enable testing

using the Metallic Test Unit (MTU).

Features

- Two ISDN circuits per card
- 2-channel TDM
- Local and Remote loopbacks
- Responds to EOC messages (Compliance ETSI ETR 080)
- Overhead indicator bit compliance ETSI ETR 080
- Remote access to metallic tip and ring
- 4-30 mA Sealing Current

IDSL Specification

Signaling

Line coding	2B1Q
Data rate (Throughput)	160 Kbps
Loopback modes	Local

Analog Parameters

Equalization	Receive	<40 dB attenuation @ 40 kHz
	Transmit	12.5 dB (2.5 Vpk)
Input impedance		135 Ω \pm 5 %
Sealing current termination		400 Ω

Environmental

Operating temperature	-35°C to +60°C
Humidity	up to 98% at 35°C
Average Power Consumption	1.5 W (excluding consumption for sealing current or power feeding)

Dimensions

5.125" (13.018 cm) tall (standing up in CBA)
 10.5" (26.67 cm) long (from front of CBA to CBA backplane)
 0.563" (1.429 cm) thick (measured along faceplate - thickest point)

Weight

0.35 lbs. (0.16 Kilograms)

Compliance

ETSI ETR 080
 TR-NWT-000397
 ITU-T G.797

4.5.12 DLC Clock Card

The Clock Card is designed for recovering the external timing source to offer the whole system a precise and reliable reference clock for data transmission. There is a slip being taking place when transmit and receive clock not synchronized with each other. The Clock Card extracts the clock from external timing source, whose format includes E1, 2048kHz Square-Wave and 64kbps Composite Clock.

The synchronization clock is seated on COT site. The output clock of this Clock Card could be carried to the subordinate COT DLC far from via optical transmission media. The output format includes E1, 2048kHz Square-Wave and 64kbps Composite Clock.

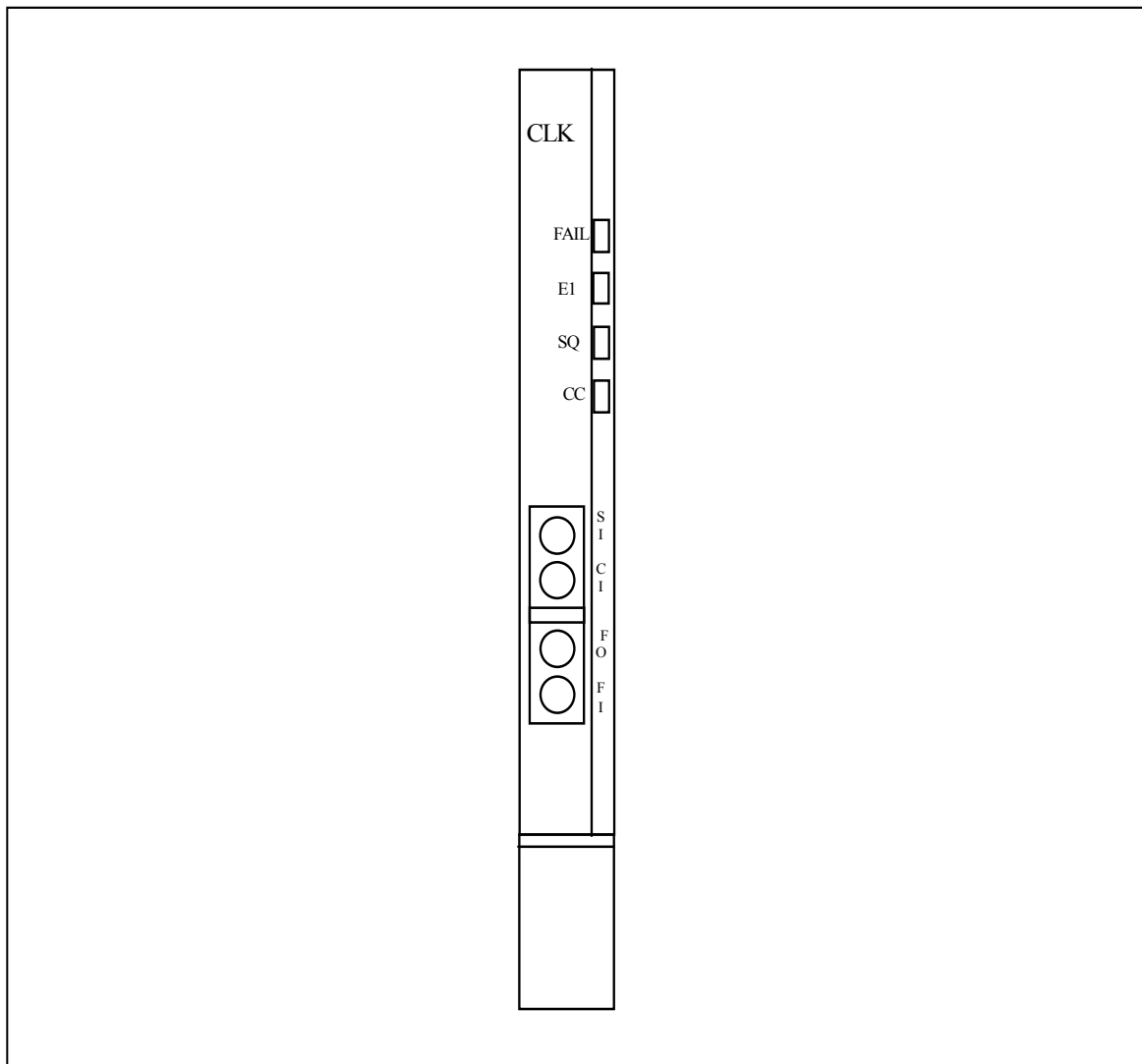

The DLC could be able to provision the priority of the clock source, e.g., (1) External Timing (2) Line Timing (3) Internal Timing. The Clock Card of the DLC should switch over to the next priority timing reference when the active (primary) reference is broke, may by loss signal or worse timing quality happened. The DLC RST will follow the loop clock from LET.

There are four LED indicators on the Clock Card front panel. A red FAIL LED indicates that the unit has failed. Three green E1, SQ and CC LEDs indicate which one is active input timing source. Only one of these three LEDs is lit green at the same time.

The Clock Card features front panel jack access for testing and monitoring. SI for 2048 kHz Squarewave Input, CI for 64kHz Composite Clock Input, FO for E1 Frame all ones Output and FI for E1 Frame all ones Input.

Features

- Complies with TA-NWT-436
- Clock Wave Reshape
- One E1, One 2048kHz Squarewave, and 64kHz Composite Clock Input Interface
- One E1, One 2048kHz Squarewave and 64kHz Composite Clock Output Interface
- Low Power Consumption

DLC CLK Card Specification

Input Clock Format

1. 2.048 Mbps \pm 50 ppm E1 Signal (G.703)
2. 2.048 MHz \pm 50 ppm Square Wave
3. 64.0 Kbps \pm 50 ppm Composite Clock

Output Clock Format

1. 2.048 Mbps \pm 50 ppm E1 Signal (G.703)
2. 2.048 MHz \pm 50 ppm Square Wave
3. 64.0 Kbps \pm 50 ppm Composite Clock

Environmental

Operating temperature	-35°C to +60°C
Humidity	up to 98% at 35°C
Average Power Consumption	2.5 W

Dimensions

- 5.125" (13.018 cm) tall (standing up in CBA)
- 10.5" (26.67 cm) long (from front of CBA to CBA backplane)
- 0.563" (1.429 cm) thick (measured along faceplate- thickest point)

Weight 0.5 lbs. (0.23 Kilograms)

Compliance TA-NWT-436

5 V5.2 Introduction

The V5 interface is the standard ITU-T/ETSI protocol, providing open interfaces for interconnection between AN (Access Network) and LE (Local Exchange).

The V5 interface is conceptually illustrated as follows.

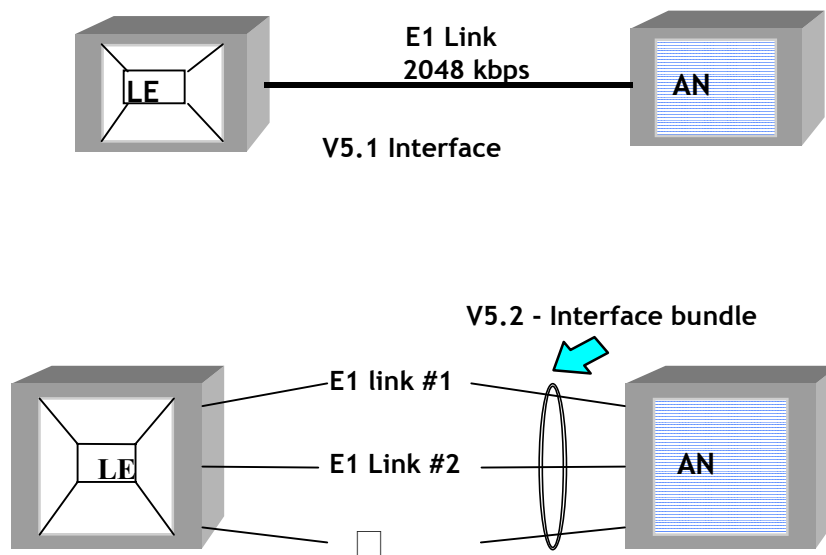

The HTC-1100E V52 & V5PU channel units are designed to provide ITU/ETSI V5 interface to the Local Exchange (LE). The V52 & V5PU cooperation is in compliance with ITU-T G.965. The HTC-1100E V5 interfaces support transparently two types of services, i.e., PSTN & ISDN. The some V52 channel units and one V5PU channel unit provide more than one 2048 Kbps interface with electrical and physical characteristics conforming to G.703.

Via link management for multiple links, up to sixteen (16) V52 links may operate in the HTC-1100E forming the V5.2 interface. The HTC-1100E V5 adopts the CCS (Common Channel Signaling) to transmit common channel control signals. In order to improve the reliability, protection procedures for the switch-over of communication paths under failure are provided. The HTC-1100E V52/V5PU channel units also support concentration capability by using a bearer channel connection (BCC) protocol.

The V52 & V5PU channel units perform signaling conversion and data link termination. Both of them have selectable alarm thresholds, BER calculation, performance monitoring statistics, and alarm history.

5.1 System Description

The connections of CPU unit, V5PU and V52 channel units(Fig 5-1) and corresponding tasks assignment diagram(Fig.5-2) is described below.

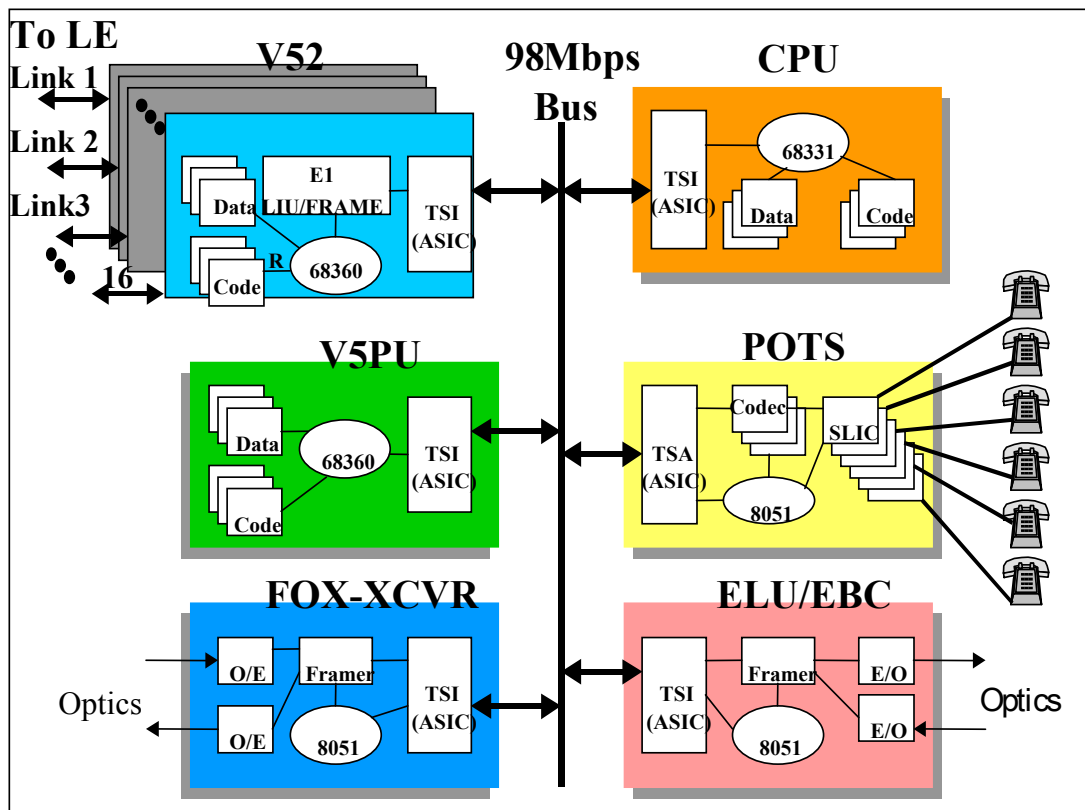

Fig5-1. The connections between V5-related units

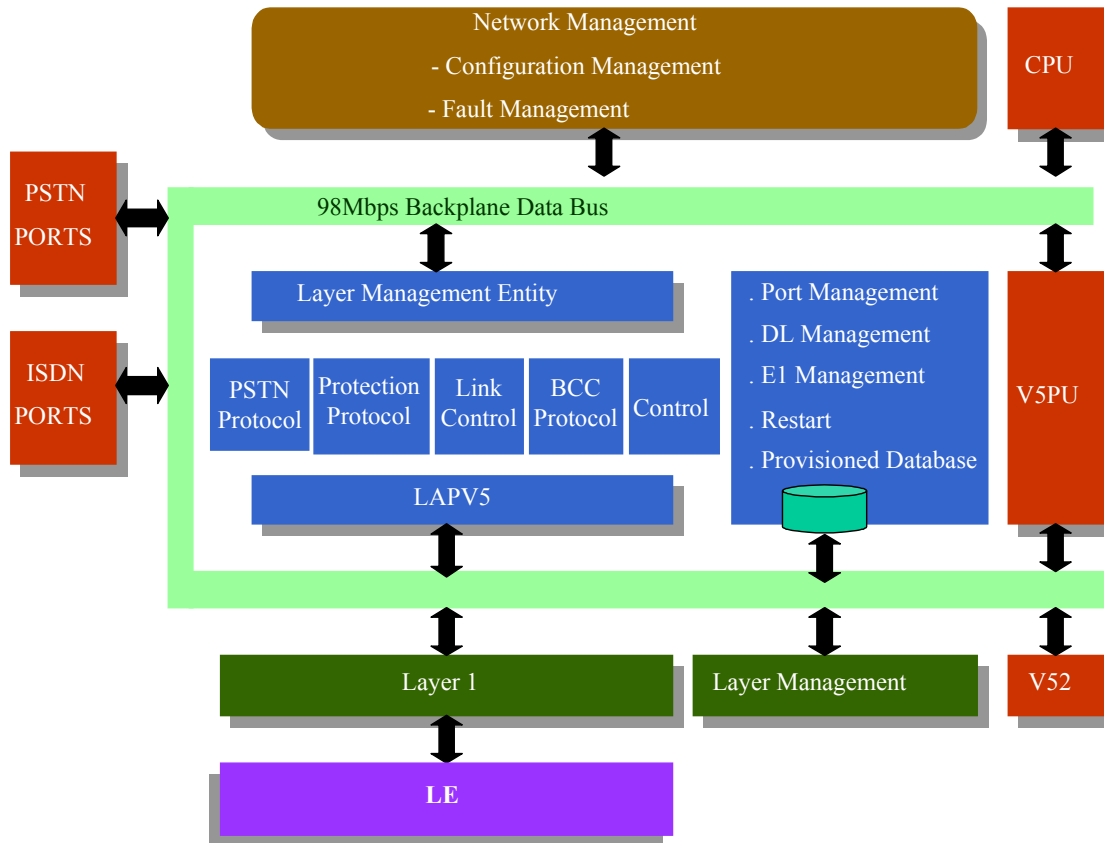

Fig.5-2 V52, V5PU and CPU units connections and individual task assignment

5.2 The software of CPU Unit

The CPU module is responsible for controlling the whole V5 DLC system resource, including of backplane bus resource, transport resource, arranging dynamic timeslot mapping and system control management functions (e.g. system module configuration, cross connection setting and so on). The V5-related configuration setting consists of preliminary V5 interface setting, E1 interface setting, PSTN, ISDN user interface setting and timeslot interface management.

CPU unit is composed of the following modules:

- System communication module
- Message routing module
- Alarm module
- Data management module
- Traffic handling module
- Transport interface module

5.3 V52 Channel Unit Features

Hardware:

- V52 Channel unit realizes E1 (2.048Mhz) physical layer function, which complied with ITU-T G.704, G.706.
- The V52 hardware modules contain LIU (Line Interface Unit), E1 framer, Micro-controller and TSI (Time Slot Interchange) chip.

Software:

- E1 performance monitoring module: executing E1 link performance monitoring
- Dynamic timeslot connection module: dynamically accomplished timeslot mapping through CPU cross connect.
- PSTN signaling conversion module: The PSTN signaling from V5 interface converts to system internal signaling format.
- Alarm report module: report to CPU the E1 interface signaling quality status.
-

5.4 V5PU Channel Unit Features

V5PU software realizes all Layer2 and Layer3 of V5.2 protocol and Layers management.

5.4.1 Layer2

The layer2 of V5.2 is LAPV5, which is based on ITU-T Q.921 LAPD protocol. V5PU channel unit takes care LAPV5-EF (Envelope Function), LAPV5-DL(Data Link) and ISDN frame relay.

5.4.2 Layer3

The layer3 contains:

- PSTN protocol: support analog subscriber voice port signal.
- BCC protocol: support Dynamic timeslot assignment and Concentration.
- Control protocol: support restart, port blocking and provisioning data.
- Link Control protocol: support link blocking and coordination of link numbering.
- Protection protocol: support primary, secondary link and C-channel switch protection.

5.4.3 Layer Management Entity (LME)

Support a group of management protocols, including of Data link management, E1 link management, protection management and provisioned database. LME makes layer2 and layer3 coupling tightly to fulfill the whole V5.2 protocol.

5.4.4 Software Features:

This module handles V5 signaling interface, through CPU provisioning. V52 channel unit consists of the modules below:

- System communication module: support the signaling channel established, management and message transfer to (from) CPU common unit and V52 channel unit.
- V5 protocol stack:
- PSTN signaling transfer: transfer the PSTN signaling from LE to V52 channel unit.
- ISDN message transfer: receiving the data link from ISDN subscriber, and transfer to C-channel, and executing the activation and deactivation of U interface
- V5 operation management control module: responsible for V5 interface status monitoring, variance-switching control and subscriber interface management etc..
- Alarm report control: report to the CPU unit V5 interface operation status, data link alarm and E1 link blocking alarm, etc.

5.5 V5.2 Integrated DLC Applications

The traditional analog interface (voice frequency) is replaced by V5 interface between AN and LE switch. The topologies, e.g. point-to-point, drop-insert still work well under V5 interface. The benefit is hardware cost down, space saving of central office and power-consuming reduction.

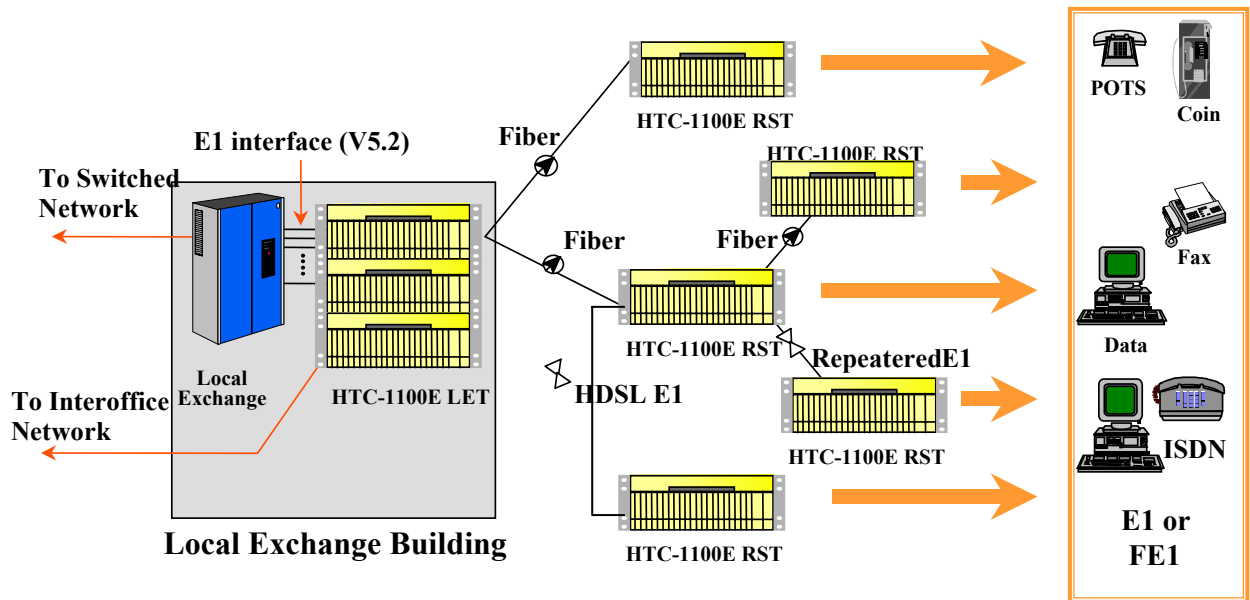

5.5.1 Application I

The following configuration will provide POTS port and V5-related units on the same shelf of RST site. Every V52 channel unit carries aggregated POTS ports on the one E1 link between V5.2 Switch and DLC's RST. The V5PU is responsible for handling V5 protocol, which is layer2 and layer3.

This application, customer need another one-pair access devices, e.g. HDSL to transport media.

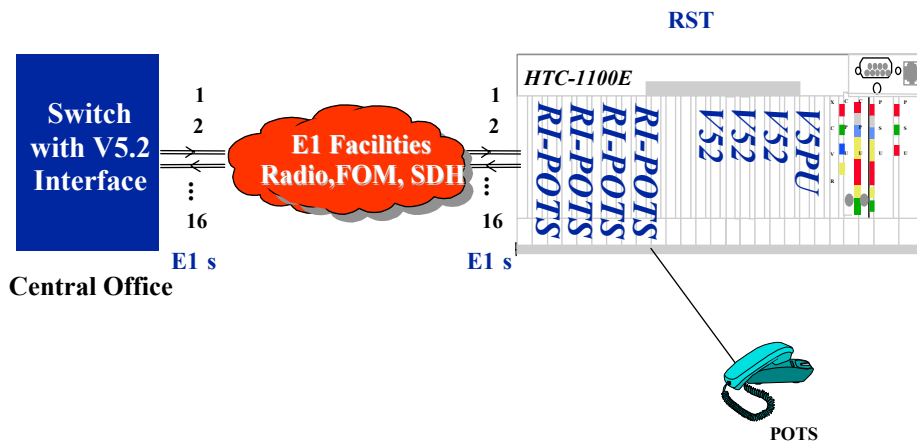

5.5.2 Application II

Using one-pair DLCs to reach far area, and don't need extra access device anymore.

Besides, network management is provided under this application.

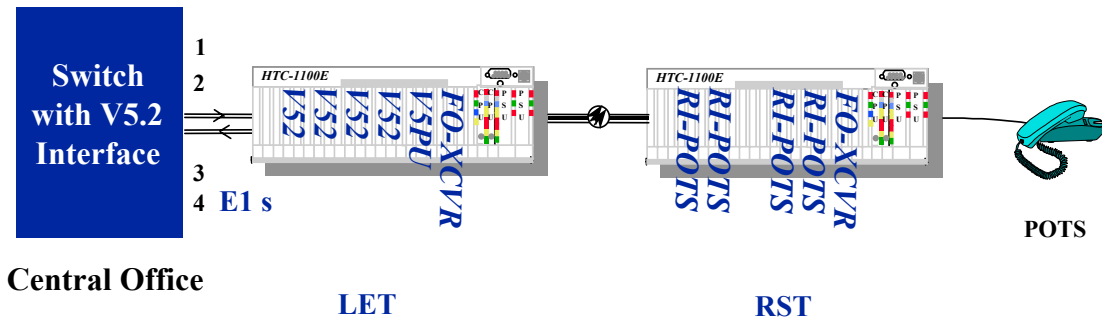

5.6 Unit Specifications And Description

1. V52 hardware

The table below is V52 channel unit H/W specification.

2. V5PU hardware

The V5PU channel unit's is the same as V52 unit's, except V5PU without E1 transceiver module. The V5PU channel unit is dedicated to perform V52 S/W protocol stack, which described in detail in next Section.

H/W Specifications	
<u>Signaling Features</u>	
Complied with	ITU-T G.965
Framing	Double frame, CRC multi-frame
Line Coding	HDB3
Error Checking	CRC4
Loopback Modes	Local, Remote
<u>Analog Parameters</u>	
Equalization	Receive Automatic Line Buildout (10 dB attenuation)
Transmit	Fixed 3.0 Vpk±0.4 Vpk
Input Impedance	120Ω(twisted pair)
<u>Environmental</u>	
Operating temperature	-35°C to +60°C
Humidity	up to 98% at 35°C
Max Power Consumption	2.5 W
<u>Dimensions</u>	
	5.125" (13.018 cm) tall (standing up in CBA)
	10.5" (26.67 cm) long (from front of CBA to CBA backplane)
	0.563" (1.429 cm) thick (Measured along faceplate - thickest point)
<u>Weight</u>	
	0.5 lbs (0.23 Kilograms)
<u>Compliance</u>	
Jitter	CCITT G.823
Cable Interface	CCITT G.703

5.6.1 V52/V5PU Faceplane

There are four LED indicators on the V52/V5PU front panel. A green ACTV LED indicates the unit is busy and must not be unplugged without first removing traffic. A red FAIL LED indicates that the unit has failed. An amber REM LED indicates that the unit is in Far End Alarm, and another amber LOC LED indicates that the unit is in Near END alarm. The transceiver features front panel jack access for testing and monitoring.

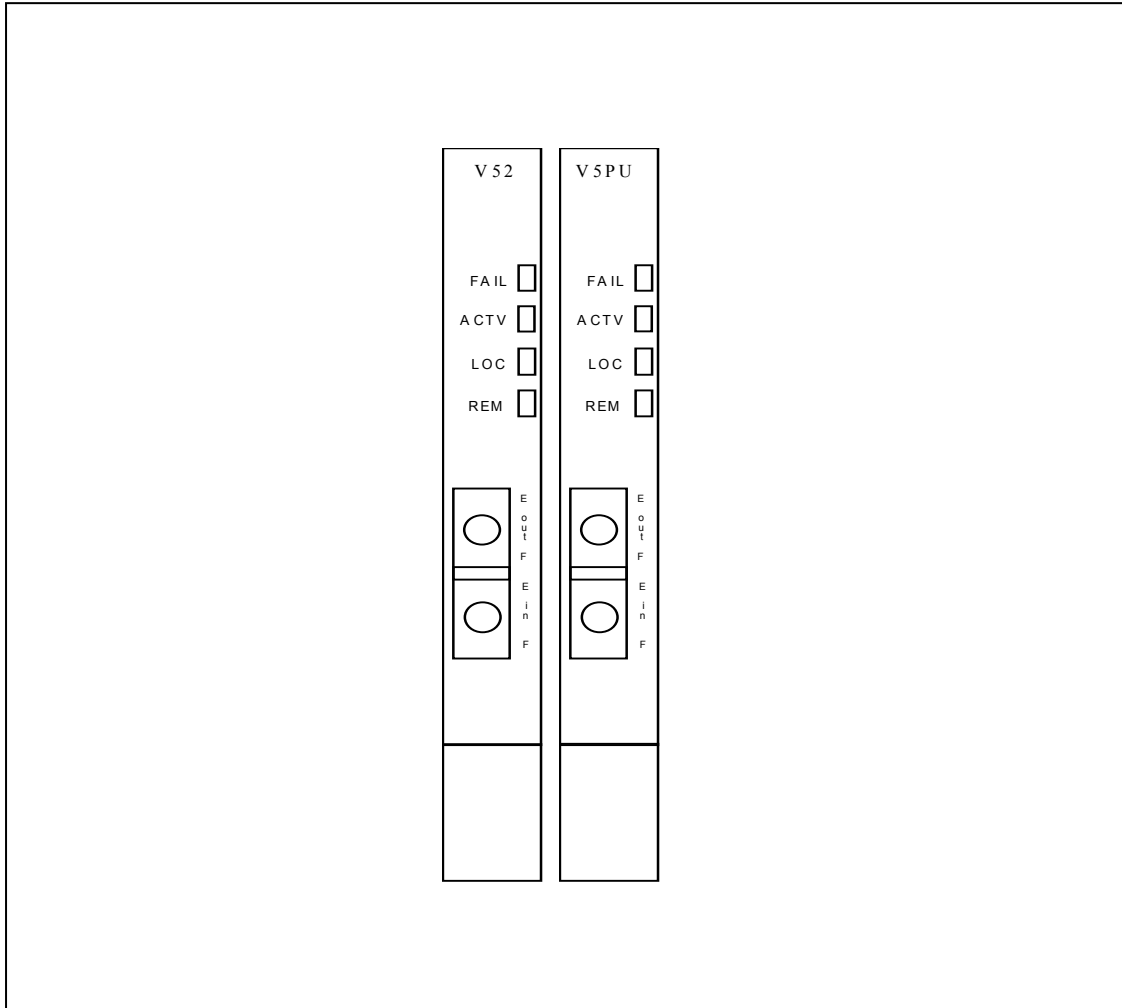

5.7 System Modification

1. ELU-T / EBC-T

ELU-T/EBC-T are used as inter-connection between primary and expansion shelf of HTC-1100E. The ELU-T/EBC-T are adopting state-of-the-art low-voltage differential signaling (LVDS) technology, which now is widely used in high-speed analog circuit techniques to provide multigigabit data transfers on copper interconnects, including serializing data, encoding the clock, and low skew features.

Low-voltage signals have many advantages, including fast bit rate, and better noise performance. And with differential signal paths, it can reduce the harmful effects of these fields to minimize radiation problems further. Furthermore, rather than multi-mode fiber cord, the inter-connection cable between ELU-T and EBC-T uses shielded Cat-5 cable to facilitate the ease and flexibility of system installation and commission.

DLC-1100E can do any expansion / modification through ELU-T / EBC-T.

2. Plug and Play Design

DLC-1100E cards can be plug in any place of DLC shelf without affecting other running card's functionality.

3. Cross Connect

DLC-1100E can do cross connect to do re-engineering job.

6 Broadband Access Channel Bank Assembly (CBA-B)

6.1 Overview

Hitron's Broadband Access Channel Bank Assembly (CBA-B) is a global xDSL broadband delivery Multi Services Access Channel Bank Assembly. It is uniquely suited to provide high density broadband ATM over DSL, traditional wideband and voice services to business and home-based customers. Future releases of Hitron's ADSL line cards and xDSL cards will enable 100% xDSL fill rate on the card slots of the HTC-1100E.

The CBA-B is an advanced, flexible digital loop carrier system capable of serving from six to more than 120 subscribers, plus 48 ADSL subscribers lines over one CBA-B with enhanced ATM multiplexer in the a rack-mountable enclosure. The CBA-B is a pre-wired, compact design shelf. It is designed for upgrade from existing narrowband service to broadband service facilitating telco. Operators quickly implement broadband service in one shelf. It utilizes a modular approach to provide service in a variety of network topologies via any transmission media. The HTC-1100E uses state-of-the-art technology to provide both traditional and forward-looking subscriber services.

The HTC-1100E architecture makes it an ideal digital loop carrier and line concentrator for new growth deployments and for upgrades to existing service in urban, suburban, and rural environments.

The HTC-1100E system consists of two basic elements: the Local Exchange Terminal (LET) in the central office; and Remote Subscriber Terminal(s) (RST) at the end of various transport media. Through various configurations of these basic elements, the HTC-1100E provides POTS and enhanced ADSL services over fiber optic, E1, HDSL E1, and analog (radio or copper) transport media. Services may be provisioned in Point-To-Point, Star, Drop and Insert, and Tree topologies. Universal and integrated (ETSI V.5) configurations are supported. An RST may be rack-mounted inside a remote switch building, built into an indoor cabinet, or configured along side outside plant facilities in a number of environmentally sealed and hardened outdoor cabinets. RSTs range in size from six to 672 lines. Subscriber services may consist of any combination of POTS, pay, ISDN, E&M, E1, fractional E1, data (analog or digital) lines and broadband xDSL service in one CBA -B.

The LET and RST are composed of identical, twenty six slot Channel Bank Assemblies (CBA) providing traditional POTS, ISDN service and enhanced ATM multiplexer which provides 48 ADSL service with built-in POTS splitter. Each CBA-B consists of two Central Processing Unit slots, two Power Supply Unit slots, and twenty-two general purpose slots and one ATM multiplexer consisting of 3 ADSL lines cards (16 ports per card), one E1 IMA and one STM-1 UNI 3.0/4.0 interface. Each CBA-B supports all common control and distribution services. There is no need for a separate common control shelf, keeping the startup costs of the HTC-1100E very low. Any service card may be plugged into any general-purpose card slot. All HTC-1100E cards are the same physical size, from the six basic channel (64 Kbps) POTS card to the SDH Fiber Optic Transceiver.

The CBA-B consists of a pre-formed, metal card cage, painted front panel (hinged yet removable for extended servicing), metal covers, and a printed circuit board backplane.

The HTC-1100E is expanded quickly and easily by adding one or more CBAs or CBA-B linked to the primary shelf by cat-5 cable. Each HTC-1100E system may be configured for up to 672 64 Kbps channels, or a maximum of eight CBAs or CBA-B.

HTC-1100E System Description

All HTC-1100E elements provide exceptional value and functionality. Plug-in cards require no hardware strapping because most options are software programmable from the craft interface. All plug-in cards are environmentally hardened to withstand harsh environments.

The integrated Time Slot Interchanger (TSI) allows the HTC-1100E to function as a true I/O cross connect with highly flexible protection and concentration capabilities. The HTC-1100E Craft Interface is simple and menu driven.

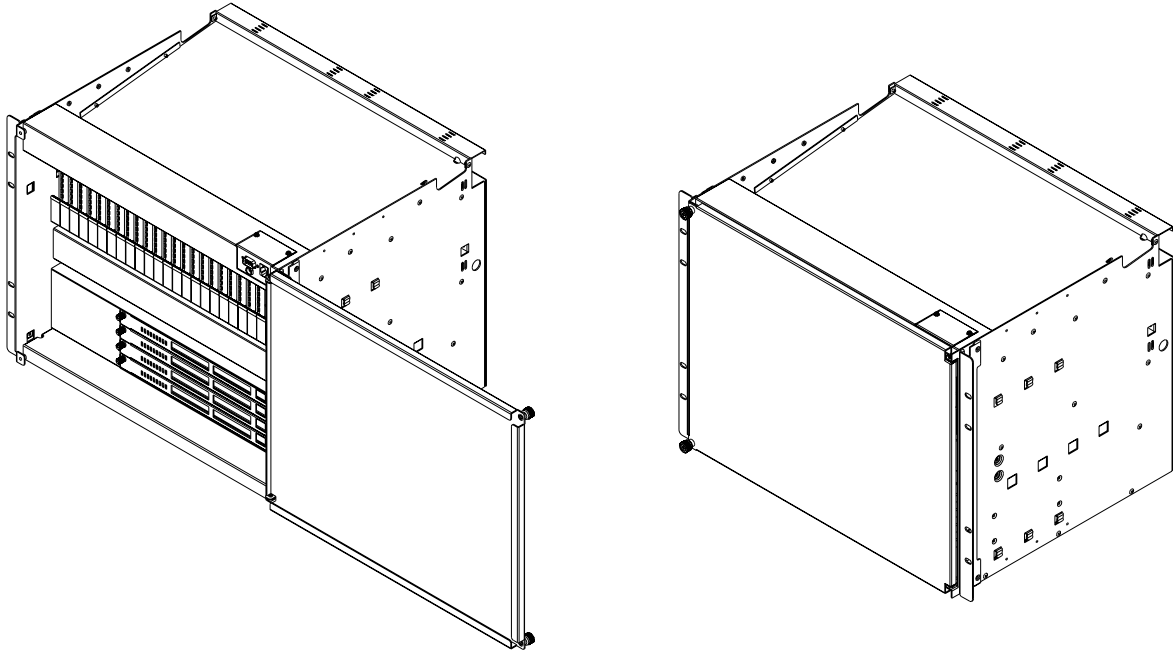

Fig. CBA-B

6.2 CBA-B Specification

Transmission

E1: 2.048 Mbps \pm 50 ppm

HDSL E1: 2.048 Mbps \pm 50 ppm

G.SHDSL : 192 to 2312 kbps (TCPAM) \pm 50 ppm

Fiber: 155.52 Mbps \pm 50 ppm

Analog: 2400 Baud \pm 100 ppm

On-hook transmission: Between ring bursts, 5 seconds after call completion

Impedance: 600 Ohm

Companding: A law 8 bits/timeslot

xDSL

G.SHDSL: 192 to 2312 kbps (TCPAM) \pm 50 ppm

IDSL: 128 Kbps 135 Ohm

Trunk Card: STM1D card/IMA8E card

Service Card: ADSL16 card, supporting 16 ports xDSL service.

E1 IF card (coordinated with IMA 8E card)

Frequency Response

300 Hz - 3.4 KHz (+0.5, -1.0 dB)

Ringing

Generation: Software programmable (20, 25, 30 or 50 Hz)

Voltage: Software programmable (65, 75, 85 or 93 Vrms - Sine)

Cadence: Ring following

Powering

LET: -42 to -60 VDC @ 4 Amps maximum

RST local AC: 220 V - 110 V charger 50 - 60 Hz 1 Amp

Temperature

Indoor: 0°C (32°F) to 50°C (122°F) ambient temperature, 10% to 80% relative humidity

Outdoor (cabinet): -0°C (-40°F) to 60°C (140°F) ambient temperature full sunlight, 5% to 95% relative humidity

Plug-in units (LET and RST): -40°C (-40°F) to 65°C (149°F), 5% to 95% relative humidity

Dimensions

CBA-B: 31 cm (12.2 in) high; 48.2 cm (19.0 in) wide; 30.5 cm (12.0 in) deep

7 Broadband CBA with full capacity SDH ADM (CBA-BS)

7.1 Overview

The CBA-BS is Hitron's DSL broadband high-density delivery platform with front access. The HTC-1100E CBA-BS is uniquely suited to provide high density DSL deployment capability for the local loop while utilizing existing backhaul facilities including E1 or HDSL copper plant as well as fiber. As part of Hitron's HTC-1100E's family of multi service access digital carrier platforms, the CBA-BS shelf can also provide narrowband voice and data services.

The CBA-BS is capable of supporting broadband and narrowband services. It can transition from copper to wireless to SDH transports, and from TDM to ATM networks. Utilizing one or more shelves, the CBA-BS is cost-effective for one to over 48 ADSL and 120 POTS lines in a shelf and is compatible with current and future public switched network infrastructures. These features push its capabilities beyond those of traditional subscriber multiplexers.

Covers the Copper transports and Optical Networks

For those of critical demands in the metropolitan network, the CBA-BS can provide seamless migration into carrier's existing SDH network and provide resilient ring topology ensuring the robust network management. Also the EOS (Ethernet over SDH) capacity enables the service of ETTB and ETTC to be easily realized.

The Broadband SDH Channel Bank Assembly of HTC-1100E is an advanced, flexible digital loop carrier system capable of serving from six to more than 120 subscribers, plus 48 ADSL subscribers lines over one CBA-BS with enhanced ATM multiplexer in a rack-mountable enclosure. The CBA-BS is a pre-wired, compact design shelf. It is designed for upgrade from existing narrowband service to broadband service facilitating telco. operators quickly implement broadband service in one shelf. It utilizes a modular approach to provide service in a variety of network topologies using any transmission media. The Htc-1100E uses state-of-the-art technology to provide both traditional and forwardlooking subscriber service.

Subscriber services may consist of any combination of POTS, pay, ISDN, E&M, E1, fractional E1, data (analog or digital) lines and broadband xDSL & EOS service in one CBA -BS.

The LET and RST are composed of identical, twenty-six slot Broadband SDH Channel Bank Assemblies (CBA-BS) providing traditional POTS, ISDN service and enhanced ATM multiplexer which provides 48 ADSL service with built-in POTS splitter. Each CBA-BS consists of two Central Processing Unit slots, two Power Supply Unit slots, and twenty-two general purpose slots and one ATM multiplexer consisting of 3 ADSL lines cards (16 ports per card), one E1 IMA and one STM-1 UNI 3.0/4.0 interface. Each CBA-BS supports all common control and distribution services. There is no need for a separate common control shelf, keeping the startup costs of the HTC-1100E very low. Any service card may be plugged into any general-purpose card slot. All HTC-1100E cards are the same physical size, from the six basic channel (64 Kbps) POTS card to the SDH Fiber Optic Transceiver.

The CBA-BS consists of a pre-formed, metal card cage, painted front panel (hinged yet removable for extended servicing), metal covers, and a printed circuit board backplane.

CBA-BS benefits and features

- Provide SNCP Fiber loop protection; ability to have 100% xDSL fill rate
- Rapid deployment from any existing cabinet
- Full EMS control integrates existing access networks
- Backwards compatibility with traditional narrowband and wideband services
- Alarm contact closure wire-wrap posts
- System timing inputs using wire-wrap posts
- Integrated fiber management tray

- Power fan assembly

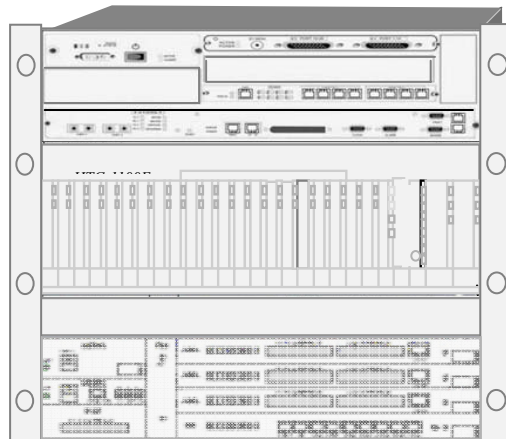

Fig. CBA-BS

7.2 CBA-BS Specification

Transmission

E1: 2.048 Mbps \pm 50 ppm

HDSL E1: 2.048 Mbps \pm 50 ppm

G.SHDSL : 192 to 2312 kbps (TCPAM)

Fiber: 155.52 Mbps \pm 50 ppm

Analog: 2400 Baud \pm 100 ppm

On-hook transmission: Between ring bursts, 5 seconds after call completion

Impedance: 600 Ohm

Companding: A law 8 bits/timeslot

SDH Tributaries

28 port E1/T1 tributaries

1 port E3/DS3 tributary

EOS: 8 port 10/100Base-T Ethernet (IEEE 802.3)

xDSL

G.SHDSL: 192 to 2312 kbps (TCPAM)

IDSL: 128 Kbps 135 Ohm

Trunk Card: STM1D card/IMA8E card

Service Card: ADSL16 card, supporting 16 ports xDSL service.

E1 IF card (coordinated with IMA 8E card)

Frequency Response

300 Hz - 3.4 KHz (+0.5, -1.0 dB)

Ringling

Generation: Software programmable (20, 25, 30 or 50 Hz)

Voltage: Software programmable (65, 75, 85 or 93 Vrms - Sine)

Cadence: Ring following

Powering

LET: -42 to -60 VDC @ 4 Amps maximum

RST local AC: 220 V - 110 V charger 50 - 60 Hz 1 Amp

Temperature

Indoor: 0°C (32°F) to 50°C (122°F) ambient temperature, 10% to 80% relative humidity

HTC-1100E System Description

Outdoor (cabinet): -0°C (-40°F) to 60°C (140°F) ambient temperature full sunlight, 5% to 95% relative humidity

Plug-in units (LET and RST): -40°C (-40°F) to 65°C (149°F), 5% to 95% relative humidity

Dimensions

CBA-BS: 44 cm (17.4 in) high; 48.2 cm (19.0 in) wide; 30.5 cm (12.0 in) deep